

FAX-L350

SERVICE MANUAL

REVISION 0

FAX-L350	H12-1573	230V	EC
FAX-L350	H12-1574	230V	UK
FAX-L350	H12-1575	230V	GER
FAX-L350	H12-1577	230V	FRN
FAX-L350	H12-1578	230V	AUS
FAX-L350	H12-1579	230V	AE
HANDSET APPARATUS			

Canon

DEC. 1999

HY8-10AM-000

Application

This manual has been issued by Canon Inc. for qualified persons to learn technical theory, installation, maintenance, and repair of products. This manual covers all localities where the products are sold. For this reason, there may be information in this manual that does not apply to your locality.

Corrections

This manual may contain technical inaccuracies or typographical errors due to improvements or changes in products. When changes occur in applicable products or in the content of this manual, Canon will release technical information as the need arises. In the event of major changes in the contents of this manual over a long or short period, Canon will issue a new editions of this manual.

The following paragraph does not apply to any countries where such provisions are inconsistent with local law.

Trademarks

The product names and company names described in this manual are the registered trademarks of the individual companies.

Copyright

This manual is copyrighted with all rights reserved. Under the copyright laws, this manual may not be copied, reproduced or translated into another language, in whole or in part, without the written consent of Canon Inc.

Copyright © 1999 by Canon Inc.

CANON INC.

Office Imaging Products Technical Support Dept. 3

5-1 Hakusan 7-Chome, Toride-city, Ibaraki 302-8501, Japan

DTP System

This manual was produced on an Apple Macintosh® personal computer, final pages were printed on Canon SUPER LASER SHOT B406 PS.

All graphics were produced with Macromedia FreeHand®.

All documents and all page layouts were created with Adobe PageMaker®.

I. MEANING OF MARKS

The marks used in this manual have the following meanings.

Mark	Meaning
	States a precaution to be taken to prevent danger to personnel, damage to the product, or damage to electronic components by discharge of static electricity. for example.
	States a precaution to be taken to prevent damage to electronic components by electrostatic discharge.
	Informs you of fire-related cautions.
	Informs you that the plug must be removed from the power outlet before starting an operation.
 NOTE	Gives useful information to understand descriptions.
 REFERENCE	Indicates sections to be read to obtain more detailed information.

II. ABOUT THIS MANUAL

This manual is divided into five parts, and contains information required for servicing the product.

Each of the above parts is further divided into the following four chapters:

Chapter 1: General Description

This part explains product specifications and the how to service the unit safely. It is very important, so please read it.

Chapter 2: Technical Reference

This part explains the technical theory of the product.

Chapter 3: Maintenance and Service

This part explains how to maintain the products for adjustment and troubleshooting and service operations and service switches.

Chapter 4: Appendix

This part explains the informations of the optional products and user data flow.

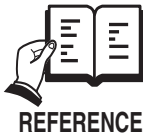

-
- For more details of user operations and user reports, see the separate volume of *USER'S GUIDE*.
 - Procedure for assembly/disassembly and greasing points are not given in this manual. See the illustrations in the separate volume of *PARTS CATALOG*.
 - Detailed description of each SSSW/parameter is not given in this manual except the new SSSWs/parameters added to this model.
See *G3 Facsimile Service Data Handbook (supplied separately)* for details them.
 - See the *G3 Facsimile Error Code List (Rev.1, supplied separately)* for details of the error codes not shown in this manual.
 - Detailed description of connector Locations and Signal Descriptions in not given in this manual.
See the *Circuit Diagram* for details them.
-

III. REVISION HISTORY

<i>REVISION</i>	<i>CONTENT</i>
<i>0</i>	<i>Original</i>

IV. TABLE OF CONTENTS

Page	<i>Chapter 1: General Description</i>
1 - 1	1. FEATURES
1 - 1	1.1 Overview
1 - 2	2. SPECIFICATIONS
1 - 2	2.1 General Specification
1 - 2	2.2 Communication Specification
1 - 3	2.3 Scanner Specification
1 - 5	2.4 Printer Specification
1 - 7	2.5 Copy Specifications
1 - 7	2.6 Interface Specifications
1 - 8	2.7 Function
1 -10	3. OVERVIEW
1 -10	3.1 External View
1 -12	3.2 Operation Panel
1 -15	3.3 Option
1 -15	3.4 Consumable
1 -16	4. DIMENSIONS
1 -18	5. SAFETY & PRECAUTIONS
1 -18	5.1 Personnel Hazards
1 -20	5.1.1 Electrical shock
1 -20	5.1.2 High-temperature parts
1 -20	5.1.3 Fire hazards
1 -21	5.1.4 Moving parts
1 -21	5.1.5 LASER beams
1 -22	5.2 General Cautions
1 -22	5.2.1 Unit cautions
1 -29	5.2.2 Toner cartridge cautions
1 -31	5.3 Servicing Cautions
1 -31	5.3.1 Damage from static charge
1 -31	5.3.2 Scanner section
1 -32	5.3.3 Printer section
1 -33	5.3.4 Paper feed section
1 -34	5.3.5 Paper load section
1 -34	5.3.6 Control boards
1 -35	5.3.7 Replacing ROM
1 -36	5.4 Data-related precautions
1 -36	5.4.1 Data in the image storage memory (DRAM)
1 -38	5.4.2 Data in the control processing memory (SRAM)
1 -39	5.4.3 SCNT board replacement precautions
1 -40	5.4.4 Data initialization through service operation
1 -41	5.5 Protective Mechanism
1 -41	5.5.1 Data battery backup function
1 -41	5.5.2 Overcurrent protection
1 -41	5.5.3 Lightning protection

- 1 -41 5.5.4 Power leakage protection
- 1 -42 6. QUALIFICATION REQUIRED FOR INSTALLATION WORK

Chapter 2: Technical Reference

- 2 - 1 1. DRIVE/ELECTRICAL SYSTEM LAYOUT
- 2 - 4 2. SCANNER MECHANISM
- 2 - 8 3. PAPER SUPPLY SECTION
- 2 -12 4. PRINTER SECTION
 - 2 -13 4.1 LASER/Scanner Section
 - 2 -13 4.2 Toner Cartridge
 - 2 -13 4.3 Toner Transfer Section
 - 2 -13 4.4 Fixing Section
 - 2 -14 4.5 Paper Feed/Eject Section
- 2 -17 5. ELECTRIC CIRCUIT
 - 2 -17 5.1 Component Block Diagram
 - 2 -18 5.2 Circuit Board Components
 - 2 -20 5.3 Flow of Image Signals
- 2 -22 6. COMMUNICATION SYSTEM OPERATIONS
 - 2 -22 6.1 FAX/TEL Switching
 - 2 -22 6.1.1 Settings
 - 2 -22 6.1.2 Parameters
 - 2 -23 6.2 Answering Machine Connection
 - 2 -23 6.2.1 Settings
 - 2 -23 6.2.2 Parameters
 - 2 -23 6.3 Manual/Auto Reception Switching
 - 2 -23 6.3.1 Settings
 - 2 -23 6.3.2 Parameters
- 2 -24 7. NEW FUNCTION
 - 2 -24 7.1 High-speed Transmission
 - 2 -24 7.1.1 V.8/V.34 protocol
 - 2 -38 7.2 JBIG Image Compression Encoding Method
 - 2 -38 7.2.1 Outline of the JBIG image compression encoding method
 - 2 -39 7.2.2 Single progression sequential bi-level image compression method
 - 2 -40 7.2.3 Encoding method
 - 2 -47 7.2.4 Construction of image data with JBIG image compression encoding
 - 2 -48 7.2.5 Explanation of bi-level image header section (BIH)
 - 2 -49 7.2.6 Explanation and parameters for each symbol used in BIH
 - 2 -50 7.2.7 Explanation of bi-level image data (BID) section
 - 2 -50 7.2.8 Explanation and parameters for each symbol used in BID

Chapter 3: Maintenance and Service

- 3 - 1 1. MAINTENANCE LIST
 - 3 - 1 1.1 Consumables
 - 3 - 1 1.2 Cleaning
 - 3 - 2 1.3 Periodic Inspection
 - 3 - 2 1.4 Periodic Replacement Parts
 - 3 - 3 1.5 Adjustment Items

3 - 3	1.6 General Tools
3 - 3	1.7 Special Tools
3 - 4	2. HOW TO CLEAN PARTS
3 - 4	2.1 Main Unit Outer Covers
3 - 4	2.2 Separation Roller
3 - 4	2.3 Separation Guide
3 - 4	2.4 White Sheet
3 - 4	2.5 Scanning Glass (Contact Sensor)
3 - 4	2.6 Paper Feed Guide
3 - 6	2.7 Paper Pickup Roller
3 - 6	2.8 Transfer Charging Roller
3 - 6	2.9 Static Charge Eliminator
3 - 6	2.10 High Voltage Terminal
3 - 6	2.11 Fixing Entrance Guide
3 - 6	2.12 Paper Face-up Eject Roller
3 - 6	2.13 Flapper
3 - 6	2.14 Document Feed Roller, Document Eject Roller
3 - 6	2.15 Pressure Roller
3 - 6	2.16 Fixing Ass'y
3 - 6	2.17 Separation Pad
3 - 8	3. REPLACING PARTS & ADJUSTMENT
3 - 8	3.1 Replacing Parts
3 - 8	3.2 Adjustment
3 - 9	4. TROUBLESHOOTING
3 - 9	4.1 Troubleshooting Index
3 -10	4.2 Errors Shown on the Display
3 -10	4.2.1 User error message
3 -12	4.2.2 Error codes
3 -18	4.3 Errors not Shown on the Display
3 -18	4.3.1 General errors
3 -19	4.3.2 Printing problems
3 -25	4.3.3 Scanning problems
3 -27	5. SERVICE SWITCHES
3 -27	5.1 Hardware Switches
3 -28	5.2 Service Data Settings
3 -28	5.2.1 Service data overview
3 -29	5.2.2 Service data registration/setting method
3 -30	5.2.3 Service data settings
3 -37	5.2.4 Explanation of service data
3 -38	5.2.5 New SSSWs/parameters added to this model
3 -53	6. TEST FUNCTIONS
3 -53	6.1 Service Test Functions
3 -53	6.1.1 Test mode overview
3 -54	6.1.2 Test mode flowchart
3 -55	6.1.3 D-RAM tests
3 -56	6.1.4 Print
3 -57	6.1.5 Modem and NCU tests

3 -60	6.1.6 Faculty tests
3 -65	7. SERVICE REPORT
3 -65	7.1 Report Output Function
3 -65	7.1.1 User report output functions
3 -67	7.1.2 Service report output functions
3 -75	8. WIRING DIAGRAM
3 -75	8.1 Wiring Diagram
3 -76	8.2 Connector Locations and Signal Descriptions

Chapter 4: Appendix

4 - 1	1. INSTALLING THE FAX-L350
4 - 1	1.1 Setting Up
4 - 1	1.2 Checking Operations
4 - 2	2. OPTION
4 - 2	2.1 HANDSET KIT
4 - 8	3. USER DATA FLOW
4 - 8	3.1 User Data Flow (by Operation Panel)
4 -11	4. MAKER-CODE

This page is intentionally left blank.

Chapter 1

General Description

1. FEATURES

1.1 Overview

This product is a G3 tranceiving facsimile based on the ITU-T recommendation. It can be used in telephone networks.

High image quality

Ultra-high quality image processing. Gives faithful reproduction of documents.

Plain paper printing with LBP

The printer section uses an LBP which employs an on-demand fixing system, operating the fan and fixing heater only when printing, and prints on plain paper.

Excellent print quality and speed

The FAX-L350 offers 600×600 dpi laser beam printing, providing you with high resolution text and graphics. The exceptional printing speed of 6 pages per minute allows you to work more effectively.

Toner detection function

This unit uses a magnetic (permeability) sensor to detect remaining toner.

Automatic dialing

There are 32 one-touch dial locations, and 100 coded-speed dial locations. Registered numbers can be retrieved using the telephone directory feature.

Improved speed

This fax unit is equipped with the ITU-T standard V.34 mode which enables transmission speeds up to 33.600 bps ,more than double the rate of older G3 fax models.

Improved data compression

JBIG, a new data compression method, compresses data to approximately one-fifth the block size attained with MMR data compression. The smaller block size requires less transmission time, and this means saving you time and money.

Memory reception

No need to worry about toner or recording paper running out in the middle of a reception. Received documents are stored in memory until they can be output later.

Delayed transmission

Documents can be sent automatically, at a preset time. This means that documents can be sent late at night, thus reducing transmission costs.

2. SPECIFICATIONS

2.1 General Specification

Type	Desktop
Body colour	Art gray
Power source	180 ~ 264V AC, 45 ~ 65 Hz,
Power consumption	standby less than 7.5W / less than 495W (when operating)
Usage environment	50.0°F ~ 90.5°F (10°C ~ 32.5°C), 20%~85% RH Horizontal ±3° or less
Operating noise	Measured in accordance with ISO standards Standby : 30 dB(A) or less Operating : 48 dB(A) or less
Dimensions (W × D × H)	14.96" × 19.02" × 11.95" (380 mm × 483 × 303.5 mm) (Not including Trays)
Weight	28.66 lbs (13 kg) Including trays

2.2 Communication Specification

Applicable lines	PSTN (Public Switched Telephone Network) PBX (Private Branch Exchange)
Handset	CT-19 (option)
Transmission method	Half-duplex
Transmission control protocol	ITU-T T30 binary protocol/ECM protocol
Modulation method	
G3 image signals	ITU-T V.27ter (2.4k, 4.8k bps) ITU-T V.29 (7.2k, 9.6k bps) ITU-T V.33 (12k, 14.4k bps) ITU-T V.17 (TC7.2k, TC9.6k, 12k, 14.4k bps) ITU-T V.34 (2.4k, 4.8k, 7.2k, 9.6k, 12k, 14.4k, 16.8k, 19.2k, 21.6k, 24k, 26.4k, 28.8k, 31.2k, 33.6k bps)
G3 procedure signals	ITU-T V.21 (No.2) (300bps) ITU-T V.8,V34 (300, 600, 1200 bps) (With automatic fallback function)
Coding	ITU-T T.4 Coding method (MH, MR) ITU-T T.6 Coding method (MMR) ITU-T T.82/T.85 Coding method (JBIG)
Error correction	ITU-T T30 (ECM)
Canon express protocol (CEP)	None

Time required for transmission protocol

Mode	Pre-message Protocol *1	Post-message Protocol *2 (between pages)	Post-message Protocol *3 (after pages)
T.30 Standard	approx. 12 sec.	approx. 4 sec.	approx. 3.5 sec.
V.34 JBIG	approx. 9 sec.	approx. 1 sec.	approx. 1 sec.

*1 Time from when other facsimile is connected to the line until image transmission begins.

*2 Post-message (between pages): Time from after one document has been sent until transmission of the next document starts if several pages are transmitted.

*3 Post-message (after last pages): Time from after image transmission is completed until line is switched from facsimile to telephone.

Minimum transmission time	10 msec. (MH,MR), 0 msec. (MMR)
Transmission output level	from -15 to 0 dBm
Receive input level	from -43 to -3 dBm
Modem IC	R288F

2.3 Scanner Specification

Type	Sheets
ADF capacity	Max. 30 sheets (A4/Letter) Max. 20 sheets (Legal)
Effective scanning width	Letter/Legal 8.42" (214 mm) A4 8.19" (208 mm)
Scanning method	Contact sensor scanning method
Scanning line density	Horizontal: 8 dot/mm (203.2 dpi) / 16 dot/mm (406.4 dpi) Vertical: Standard 3.85 line/mm (97.79 dpi) Fine 7.7 line/mm (195.58 dpi) Superfine/Ultrafine 15.4 line/mm (391.16 dpi)
Scanning speed	Standard 5 sec./page Canon FAX Standard Chart No. 1 scanning
Image modes	Halftone (PHOTO mode)
Scanning density adjustment	3 density level
Halftone	64-gradation error diffusion system (UHQ)

Scanning range

Sheet dimensions (W × L)

Maximum	8.58" × 14.41" (218 mm × 336 mm)
Minimum	3.5" × 1.75" (88.9 mm × 63.5 mm)
Thickness	
multiple pages:	0.002" ~ 0.005" (0.06 mm ~ 0.13 mm)
	40~90 g/m ²
1 pages:	0.002" ~ 0.017" (0.06 mm ~ 0.43 mm)
	34.7~340 g/m ²

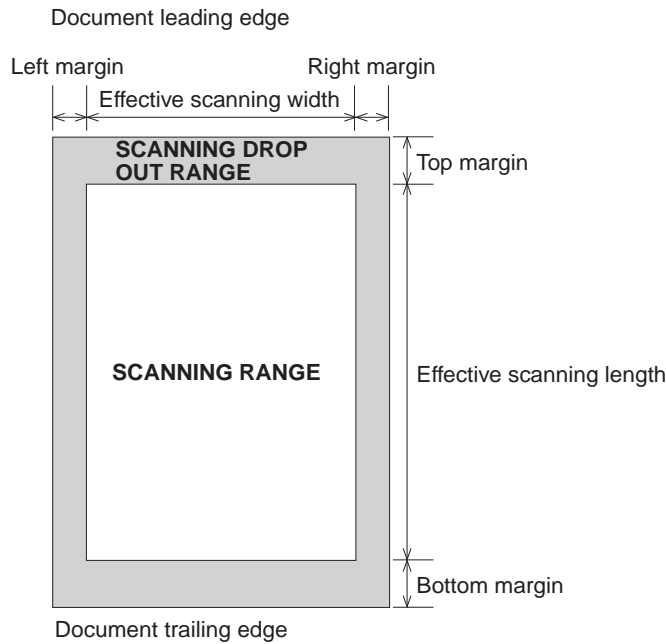

Figure 1-1 Scanning Range

Item	A4	Letter	Legal
Effective scanning width	8.19" (208 ±1.0 mm)	8.42" (213.9 ±1.0 mm)	8.42" (213.9 ±1.0 mm)
Effective scanning length	11.53"±0.12" (293 ±3.0 mm)	10.84"±0.12" (275.4 ±3.0 mm)	13.84"±0.12" (351.6 ±3.0 mm)
Left margin	0.04" ±0.08" (1.0 ±2.0mm)	0.04" ±0.08" (1.0 ±2.0mm)	0.04" ±0.08" (1.0 ±2.0 mm)
Right margin	0.04" ±0.10" (1.0 ±2.5 mm)	0.04" ±0.10" (1.0 ±2.5 mm)	0.04" ±0.10" (1.0 ±2.5 mm)
Top margin	0.08" ±0.08" (2.0 ±2.0 mm)	0.08" ±0.08" (2.0 ±2.0 mm)	0.08" ±0.08" (2.0 ±2.0 mm)
Bottom margin	0.08" ±0.08" (2.0 ±2.0 mm)	0.08" ±0.08" (2.0 ±2.0 mm)	0.08" ±0.08" (2.0 ±2.0 mm)

Units are inches with mm shown in parentheses.



NOTE

- Document scanning width “A4/LTR” is set in service data #1 SSSW SW06, bit4.
- Skew area is not taken into consideration.
- The feed precision of the original is included in the scanning range values.

2.4 Printer Specification

Printing method	LASER Beam Printer			
Printing Cartridge				
Products name	Canon FX3 Cartridge			
Product code	H11-6381-001			
Valid period	Displayed on carton (2.5 years from date of manufacture)			
Storage conditions	Temperature	from 32.0°F to 95.0°F (0°C to 35°C)		
	Humidity	from 35% to 85% RH		
Yield	Approx. 2700 pages (black rate 4% chart)			
Toner detection	Yes (Toner out detect)			
Printing speed	Approx. 6 pages/minute			
Printing resolution	Standard	8 dots/mm × 3.85 line/mm		
	Fine	8 dots/mm × 7.7 line/mm		
	Superfine	8 dots/mm × 15.4 line/mm		
	Ultrafine	16 dots/mm × 15.4 line/mm		
Paper output tray stacking (when using the recommended paper)				
Face down delivery slot	Approx. 50 sheets			
Face up delivery slot	1 sheet			
Paper tray				
Paper supply method	ASF (Auto Sheet Feeder)			
Kind of paper tray	MULTI-PURPOSE TRAY			
Paper capacity	Max. 0.40" (10 mm) thickness			
	Plain Paper	Lavel Paper	Envelopes	Transparency
MULTI-PURPOSE TRAY	Approx. 100 sheets	Approx. 70 sheets	Approx. 7 envelopes	1 sheet
Paper cassette capacity				
1.08" (27.5 mm) or less in stacking height (Approx. 250 sheets)				
Recommended paper				
KANGAS				
Weight	80 g/m ²			
Paper size	A4			
Manufactured by	KANGAS			
NEUSIEDLER Canon Paper				
Weight	80 g/m ²			
Paper size	A4			
Manufactured by	NEUSIEDLER			

Printing range

Paper dimensions (W × L)

Maximum	8.50" × 14.02" (216 mm × 356 mm)
Minimum	3.64" × 5.0" (92.4 mm × 127 mm)
Letter	8.50" × 10.98" (216 mm × 279 mm)
Legal	8.50" × 14.02" (216 mm × 356 mm)
A4	8.27" × 11.69" (210 mm × 297 mm)
Thickness	
MULTI-PURPOSE TRAY	64~90g/m ²
MANUAL FEED SLOT	64~105g/m ²

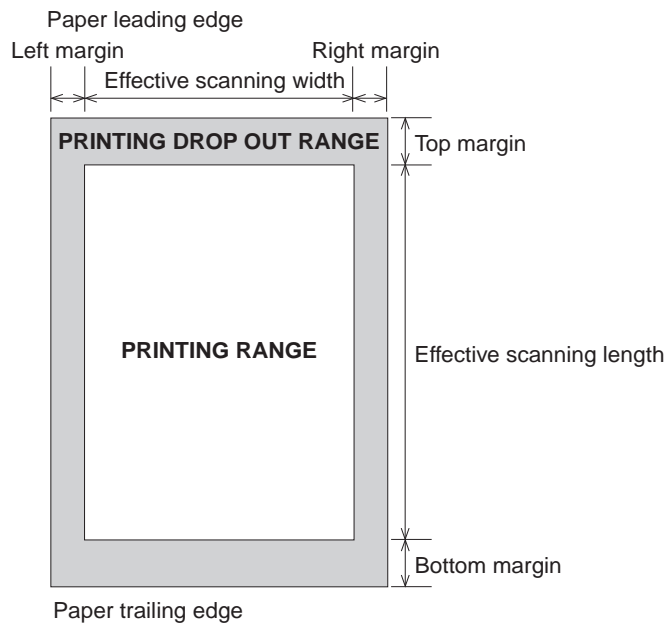

Figure 1-2 Printing Range

Item	A4	Letter	Legal
Effective printing width	8.11" ±0.08" (206 ±2.0 mm)	8.19" ±0.08" (207.9 ±2.0 mm)	8.19" ±0.08" (207.9 ±2.0 mm)
Effective printing length	11.38" ±0.12" (289 ±3.0 mm)	10.69" ±0.12" (271.4 ±3.0 mm)	13.69" ±0.14" (347.6 ±3.5 mm)
Left margin	0.08" ±0.08" (2.0 ±2.0 mm)	0.16" ±0.08" (4.0 ±2.0 mm)	0.16" ±0.08" (4.0 ±2.0 mm)
Right margin	0.08" ±0.12" (2.0 ±3.0 mm)	0.16" ±0.12" (4.0 ±3.0 mm)	0.16" ±0.12" (4.0 ±3.0 mm)
Top margin	0.08" ±0.08" (2.0 ±2.0 mm)	0.08" ±0.08" (2.0 ±2.0 mm)	0.08" ±0.08" (2.0 ±2.0 mm)
Bottom margin	0.24" ±0.16" (6.0 ±4.0 mm)	0.24" ±0.16" (6.0 ±4.0 mm)	0.24" ±0.18" (6.0 ±4.5 mm)

Units are inches with mm shown in parentheses.



NOTE

- The header is printed in the printing range.
- Skew area is not taken into consideration.
- The feed precision of the original is included in the scanning range values.
- Print area when all-black pattern from Test Print modes are outputted.

2.5 Copy Specifications

Color copy	None	
Multiple copy	99 copies	
Copy resolution	Scanning	600 dpi × 600 dpi (direct copy) 300 dpi × 600 dpi (memory copy)
	Printing	600 dpi × 600 dpi
Copy magnification ratio	100%, 90%, 80%, 70%	



NOTE

- When one copy is specified at a magnification ratio of 100%, the direct copy mode is entered. When two or more copies are specified, the memory copy mode is entered.
- When the magnification ratio is 90%, 80% or 70%, the memory copy mode is entered.
- When long originals are scanned in the direct copy mode, only the area that can be printed on a single page is copied, and copies are not made over multiple pages.

2.6 Interface Specifications

The parallel interface sends 8 bits (one byte) of data at one time and is transistor-transistor-logic (TTL) compatible.

Interface type

IEEE P1284/Bi-directional parallel

Data transmission

8-bit parallel interface (IBM PC or compatible)

Synchronizing signal

STROBE signal from the computer

Handshake

BUSY/ACKNLG

Interface connectors

Printer side Amphenol 57-40360 or equivalent

Cable side Amphenol 57-30360 or equivalent

Recommended interface cable

Type Twisted-pair shielded cable

Material AWG No.28 or larger

Length Up to 6.56 feet (2.0 m)

Signal voltage levels

Low level 0.0 V to +0.4 V

High level +2.4 V to +5.0 V

2.7 Function

Dialling

Manual dialling	Numeric button
Auto dialing	Max. 120 digits (Ave. 39 digits)
	One-touch: 32
	Coded speed: 100
Group dial	Max. 131 locations
Redial	Numeric button redial function (Max. 120 digits)

Transmission

Broadcast transmission	Max. 133 locations (One-touch:32, Coded speed:100, Numeric button:1)
Delayed transmission	No. of Destination Max. 133 No. of Reservation Max. 20
Confidential Tx/Rx	Yes (by Subaddress Sending)
Relay broadcasting originating	Yes (by Subaddress Sending)
Password/Subaddress sending	Max. 20 digits

Reception

FAX/TEL switching	Yes
Method	CNG detection
Message	None
Pseudo CI	None
Pseudo ring	Yes
Pseudo ringback tone	Yes
Reduction settings for reception	Yes
Automatic reduction of reception images	Yes (100%~70%)
Built-in Answering machine	None
Answering machine connection	Yes (Telephone answering priority type)
Remote reception	Yes (Remote ID method)
Memory lock reception	None
Reception printing in reverse order	Yes (When using face-down delivery slot)

Polling

Polling transmission	Yes The document is accumulated into the memory ahead of time, then transmitted when there is a polling request from the other party.
Polling reception	Yes Receives from a fax in automatic transmission mode
Subaddress (ITU-T standard)	Max. 20 digits
Password (ITU-T standard)	Max. 20 digits

Others

Dual access

File No. of reservation Max. 20 files

Closed network

None

Direct mail prevention

Telephone numbers compared Telephone numbers registered under one-touch and coded speed dial, and aTSI signal

Number of digits Lower 6 digits (number of digits can be changed with service data #3)

Memory box

None

Memory backup

Backup contents Dial registration data, User data, Service data, Time

Backup IC 218160 bit SRAM for control (with built-in CPU)

Backup device Lithium battery 3 V DC/ 220 mAh

Battery life Approx. 5 years

Image data backup

Backup contents Memory reception, memory copy, delayed transmission and broadcast transmission image data, activity management report

Backup IC 2.5 M byte DRAM

Backup device Rechargeable capacitor 2.5 V/4F

Battery life 40 cycles with 100 % discharge (Temperature 77°F (25°C))

Activity management

Yes

a) User report

Activity report (Every 20 transactions: always transmission and reception together)

Activity report (sending/receiving)

One-touch speed dialing list

Coded speed dialing list

Group dialing list

User's data list

Error report

Memory clear list

Multi activity report

Document memory list

b) Service report

System data list

System dump list

Error list

Transmitting terminal identification

Yes

Time

Management data Year/month/date/day/hour/minute (24 hour display)

Precision ±60 sec per month

Display

2 row × 20 digits

Completion stamp

None

Program key

None

Demo print function

None

HELP function

None

3. OVERVIEW

3.1 External View

Front View

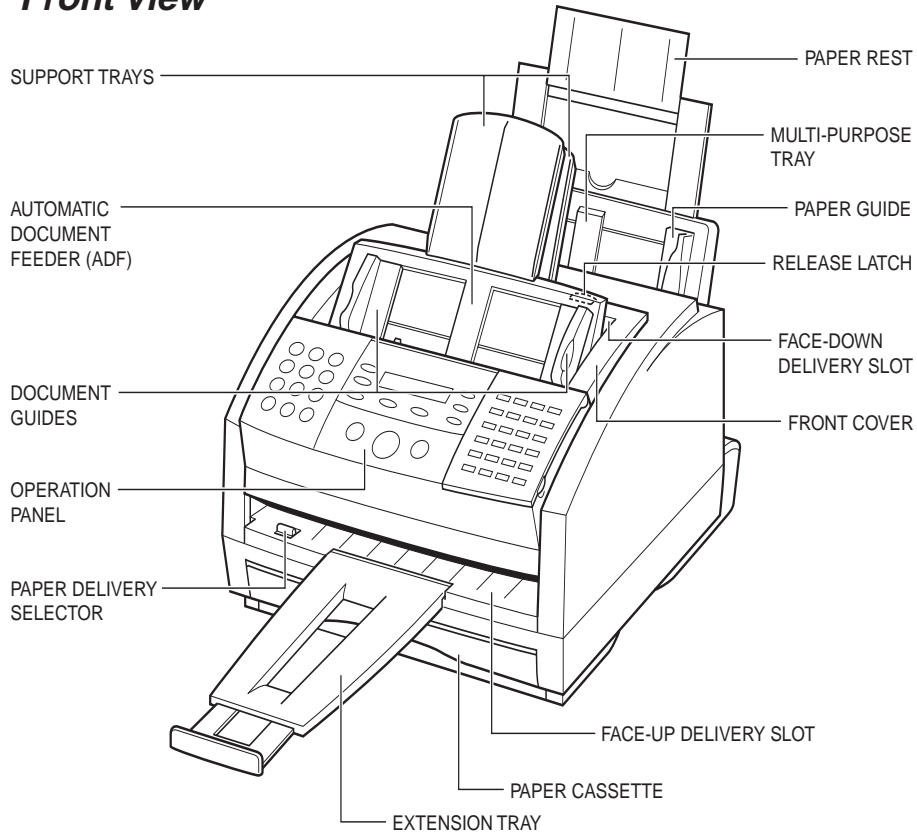
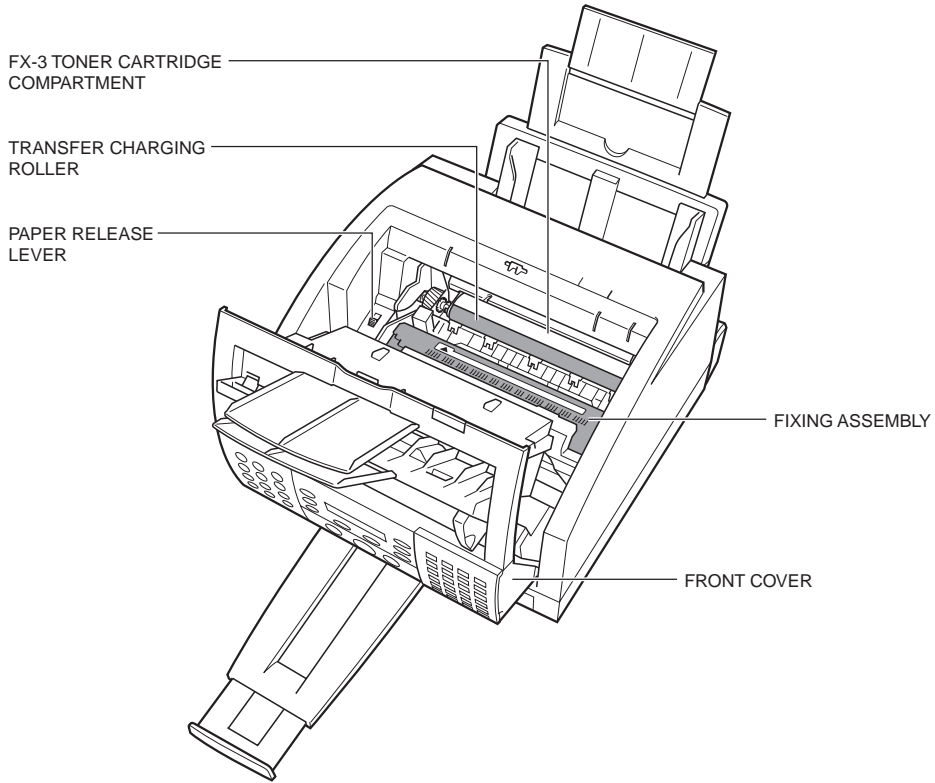

Figure 1-3 External View (1)

Inside View



Rear View

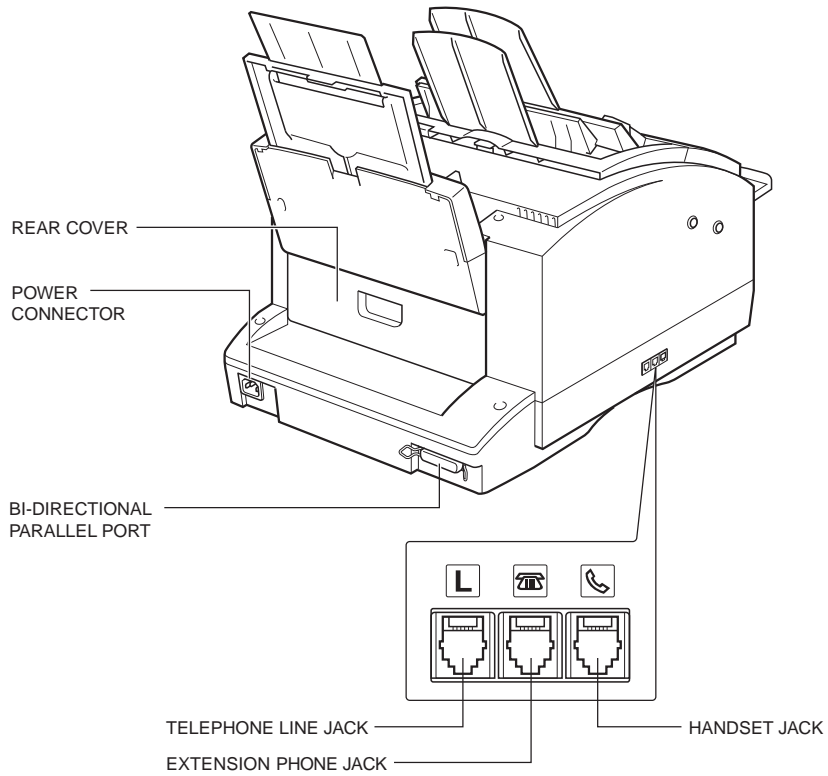
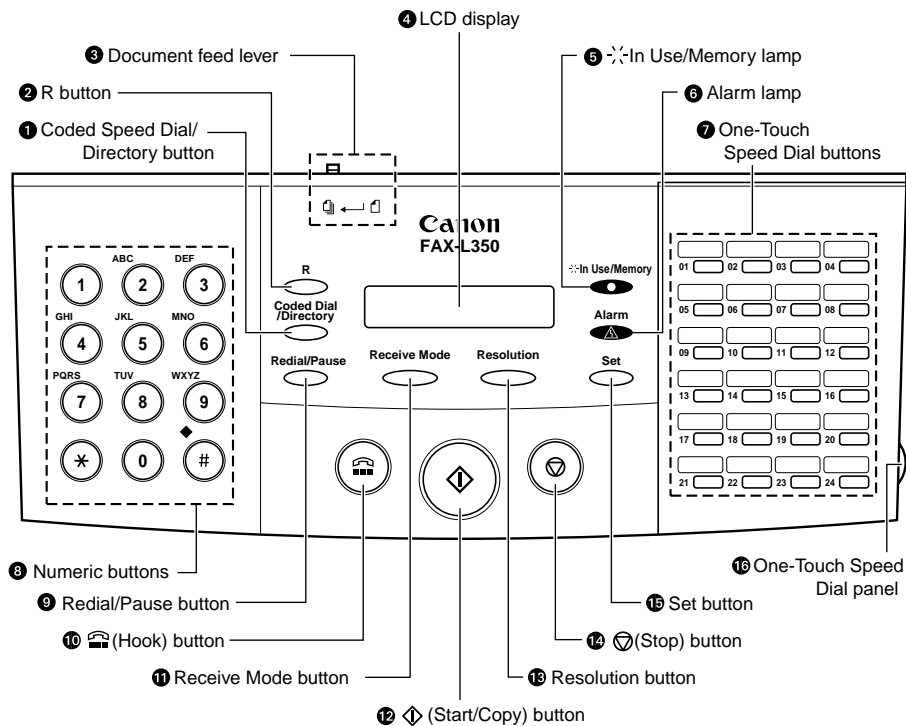

Figure 1-4 External View (2)

3.2 Operation Panel

The Operation Panel



1 Coded Dial/Directory button

Press this button to dial a fax/telephone number that you have registered for coded speed dialing, or to look up the other party's name and retrieve the number for dialing.

2 R button

Press this button to dial an outside line access number when the unit is connected through a switchboard (PBX).

3 Document feed lever

Set this lever to the left (☰) for automatic document feed, or to the right (☷) for manual document feed.

4 LCD display

The LCD display shows messages and prompts during operation, and displays selections, text, numbers and names when registering information.

Figure 1-5 Operation Panel (1)

5 ✨ **In Use/Memory lamp**

Lights when the telephone line is being used or a document has been received in memory

6 **Alarm lamp**

This lamp flashes when an error occurs, or when the FAX-L350 is out of paper or toner.

7 **One-Touch Speed Dial buttons**

Use these buttons for One-Touch Speed dialing.

8 **Numeric buttons**

Use these buttons to enter numbers and names when registering information, and to dial fax/telephone numbers that are not registered for automatic dialing.

Redial/Pause button

Press this button to redial the last number that was dialed using the numeric buttons, or to enter pauses between digits when dialing or registering fax numbers.

10 📞 **(Hook) button**

Press to dial with the numeric buttons when using manual sending.

11 **Receive Mode button**

Use this button to select the receive mode for receiving faxes.

12 ⏪ **(Start/Copy) button**

Press this button to begin faxing, or copying.

13 **Resolution button**

Press this button to select the resolution the FAX-L350 will use for the document you want to fax, or copy.

14 ⏹ **(Stop) button**

Press this button to cancel sending, receiving, or any other operation.

15 **Set button**

Press this button to select a menu item when registering information.

16 **One-Touch Speed Dial panel**

Open this panel to access the registration buttons.

Figure 1-6 Operation Panel (2)

Special Function Buttons (One-Touch Speed Dial panel open)

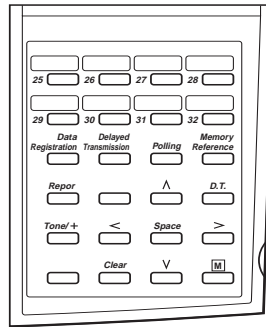

- ❑ **Data Registration button**
Use this button to register user's data, speed dialing, and other important settings for sending and receiving.
- ❑ **Delayed Transmission button**
Press this button to register a time for delayed sending.
- ❑ **Polling button**
Use this button to set a document for polling sending, and to poll the other fax to receive a document.
- ❑ **Memory Reference button**
Use this button to delete or resend documents stored in memory, or to print a list of documents in memory
- ❑ **Report button**
Use this button to print activity reports.
- ❑ **D.T. button**
Press this button to confirm the dial tone when dialing a number. (Not used in the UK, Hong Kong, Australia, New Zealand, Singapore, or Malaysia.)
- ❑ **Tone/+ button**
Press this button to use tone dialing temporarily when your unit is set for pulse dialing. Press also to enter a + sign when registering your fax/telephone number.
- ❑ **Space button**
Use this button to enter a space between letters and numbers when you are registering information.
- ❑ **Clear button**
Use this button to clear an entire entry during information registration.
- ❑ **^ v Search buttons**
Use these buttons to scroll the display so you can see other options and selections in the menus during data registration.
- ❑ **< > Cursor buttons**
Use these buttons to move the cursor left or right during data registration.
- ❑ **M button (UK only)**
In the U.K., if you wish to use the UK Call, Global Call, and Day Call Services of Cable and Wireless Communication Ltd., use this button.

Figure 1-7 Operation Panel (3)

3.3 Option

Handset Kit

3.4 Consumable

Toner cartridge

FX3 cartridge is used.

4. DIMENSIONS

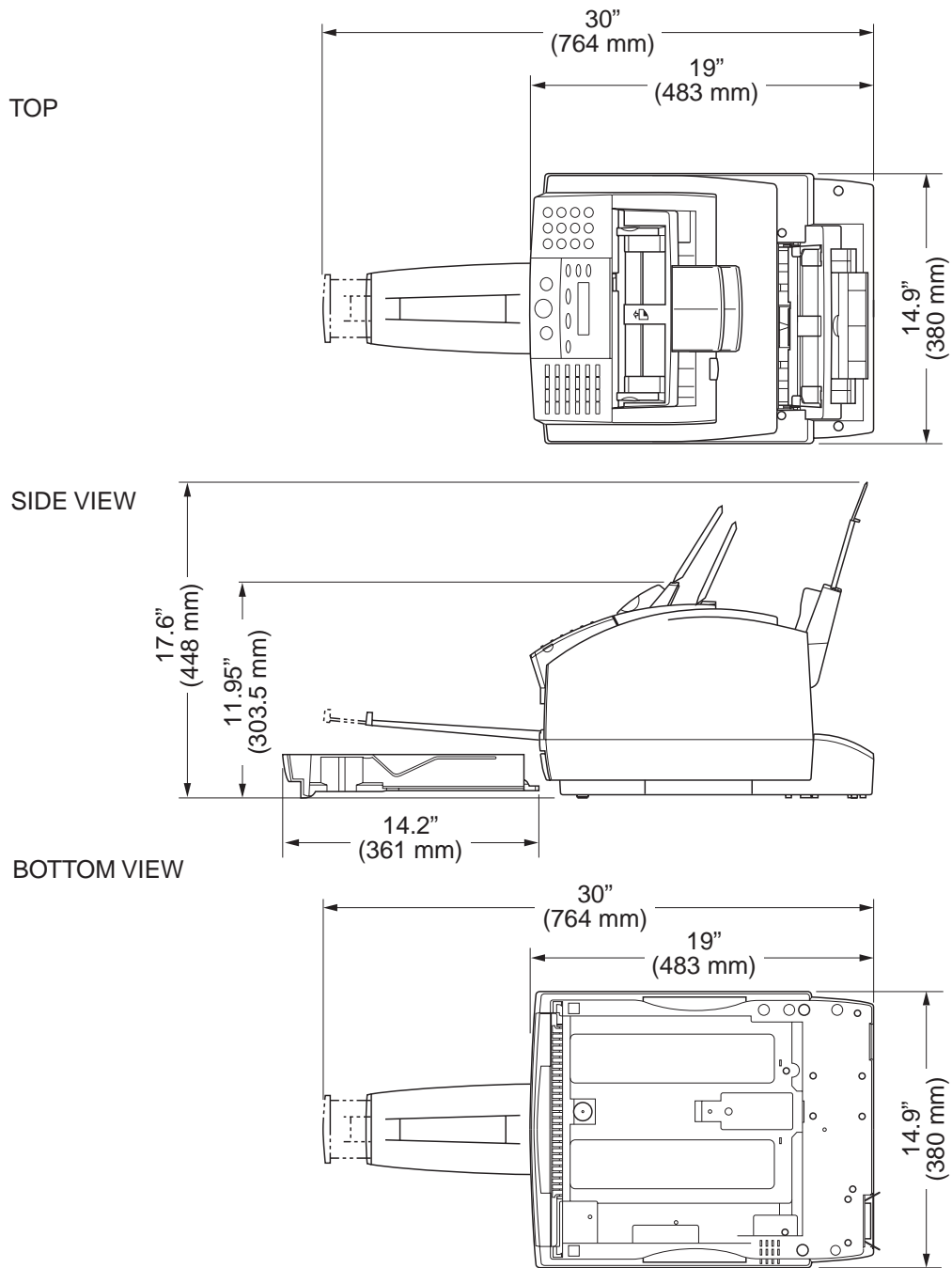

Figure 1-8 Dimensions

This page intentionally left blank

5. SAFETY & PRECAUTIONS

5.1 Personnel Hazards

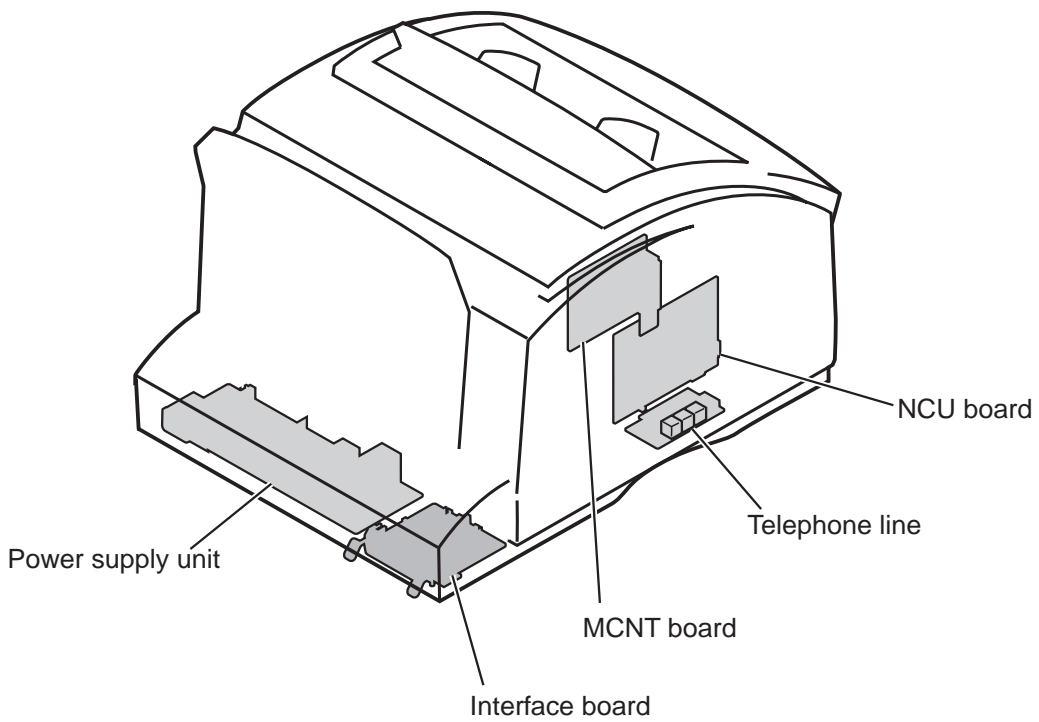
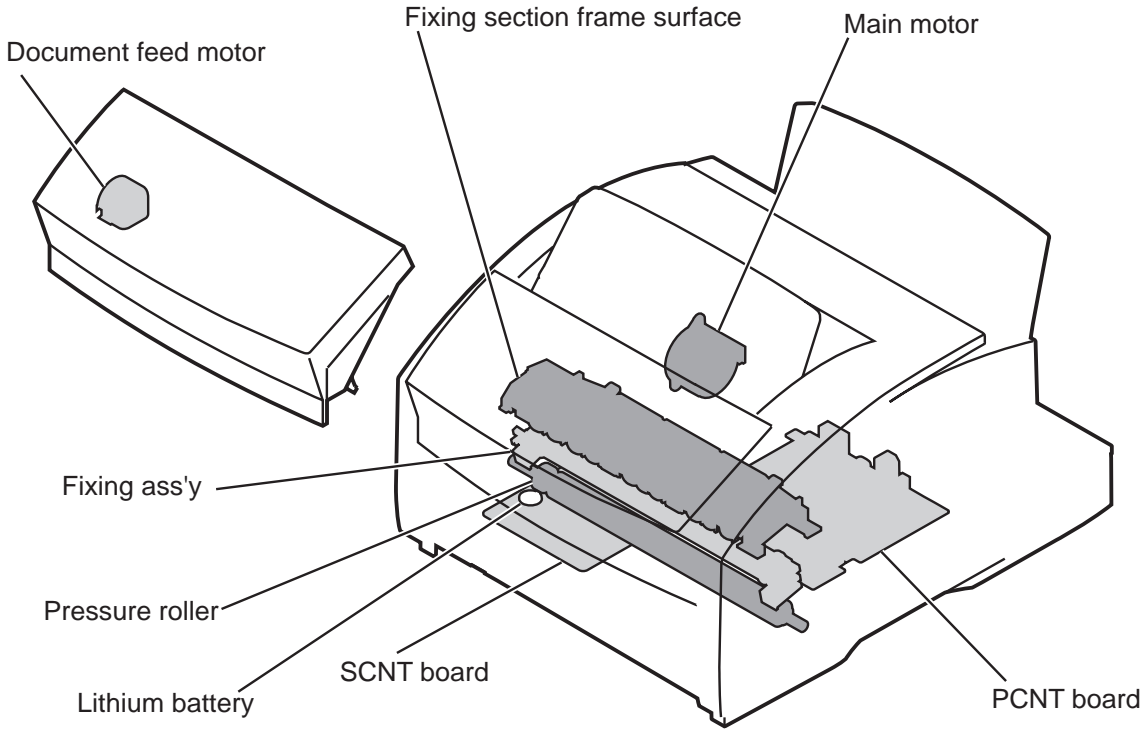

Figure 1-9 Personnel Hazards (1)

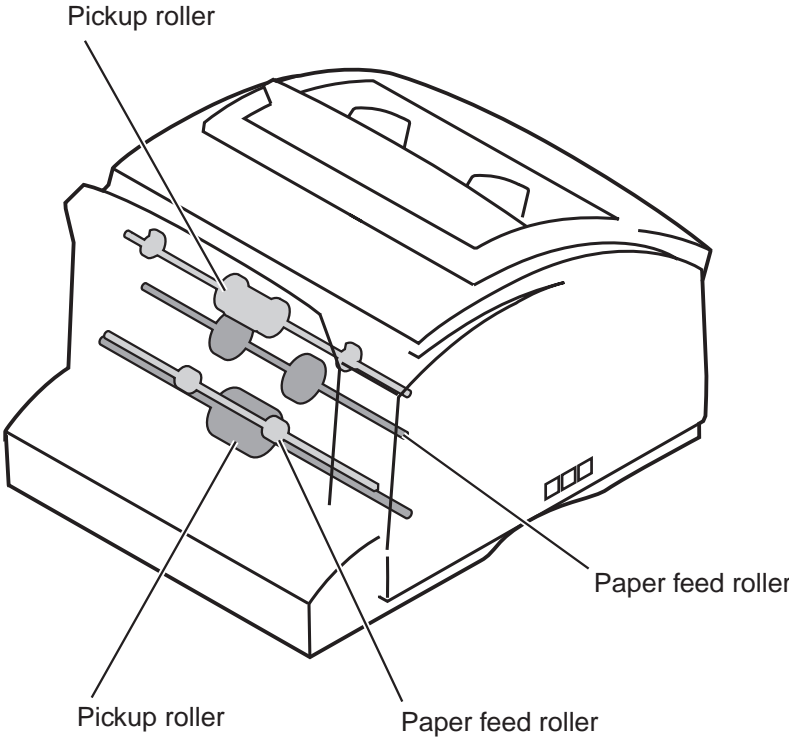
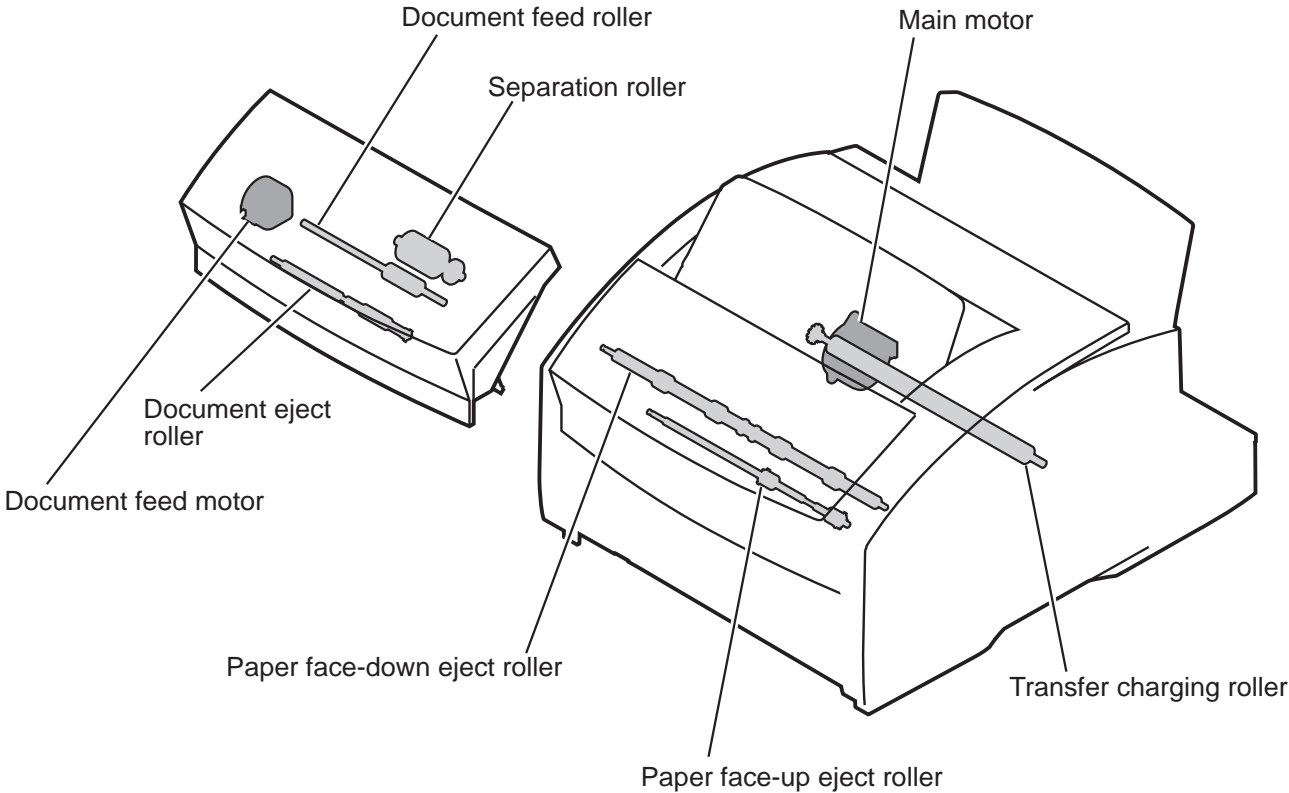
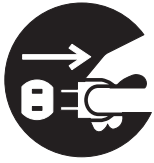

Figure 1-10 Personnel Hazards (2)

5.1.1 Electrical shock



Electrical shock hazard

- To prevent electrical shock, be sure to disconnect the power cord and modular jack before disassembly.
 - Remove grounding wrist straps before servicing this unit while the FAX's power is on. Otherwise, electrical shock may occur.
-



Power supply unit

When power is supplied to this unit, 230 VAC will be supplied to the primary side.

Telephone line

NOTE

If a telephone line is connected to this unit, 48 VDC will be supplied by this line. When a call signal is received, a voltage of 90 VAC Vrms will be supplied.

5.1.2 High-temperature parts



High-temperature warning

To prevent skin burns, disconnect the power cord and let this unit stand for at least 10 minutes to allow hot parts to cool.



How to treat burns

Heat of about 122°F (50°C) or more causes burns. Also, the longer the contact, the more severe the burn.

NOTE

When treating a burn, the first minute after receiving the burn is the most important. Cool the burn immediately with cold running water. In case of a serious burn, seek medical attention immediately.

High-temperature parts

The parts which get hot during operation are indicated. For the location of these parts, refer to the figures.

(Ambient temperature 95°F (35°C) continuous copy operation)

Document feed motor (approx. 168°F (76°C))

Main motor (approx. 145°F (63°C))

Fixing section frame surface (approx. 203°F (95°C))

Fixing ass'y and pressure roller (approx. 338°F (170°C))

Power supply unit (Max. ~ 187°F (86°C))

PCNT board assembly (Max. ~ 160°F (71°C))

5.1.3 Fire hazards



Do not dispose in fire.

Do not dispose of lithium batteries in fire. Doing so may rupture the battery and expose flammable materials.

Follow applicable local regulations when disposing of the SCNT board assembly's lithium battery.

Fire hazard

When using IPA or other solvents during servicing, heat or sparks from internal electronic circuits can ignite the solvent. Before using such solvents, be sure to turn off the power source and wait until the high-temperature parts cool. Use the solvent in a well-ventilated area.

5.1.4 Moving parts



Moving parts

To prevent mishaps due to moving or rotating parts during servicing, be sure to disconnect the power cord before disassembly.

5.1.5 LASER beams

This fax is a Class 1 Laser Product as defined in the EN60825 (IEC825) Radiation Safety of laser products, equipment classification, requirements and user's guide. This means that this product uses lasers that do not radiate dangerous laser beam and conforms to the regulations because the laser beam does not affect the user during operations.



Warning

If the LASER light gets in your eyes, it will damage the retina. Figure 1-11 is a LASER beam warning label which is placed on the LASER/scanner unit. Always remain within the contents of this manual when servicing, and do not carry out any other maintenance. Within the range of service work in this manual, you will not be exposed to dangerous LASER light.



Figure 1-11 LASER beam warning label



Disassembly Prohibited

Never disassemble or alter the printer section LASER/scanner unit. There is no servicing that requires you to disassemble the LASER/scanner unit.



NOTE

Safety Mechanism

There is a safety mechanism that electrically stops LASER emission and scanner mirror rotation when the front cover is opened and when the microswitch on the body frame has operated.

Also there is a safety mechanism that mechanically closes the shutter in the LASER/scanner unit to cut off the laser path, when the front cover is opened.

5.2 General Cautions

5.2.1 Unit cautions

Safety Instructions

Read these safety instructions thoroughly before using your FAX-L350, and keep them handy in case you need to refer to them later.



Caution

Except as specifically described in this user's guide, do not attempt to service the FAX-L350 yourself. Never attempt to disassemble the unit: opening and removing its interior covers will expose you to dangerous voltages and other risks. For all service, contact your local authorized Canon dealer or the Canon help line.

- Always follow all warnings and instructions marked on the FAX-L350.
- Use the FAX-L350 only on a sturdy, stable, level surface. If the unit falls, it could be seriously damaged.
- Do not use the FAX-L350 near water. If you spill liquid on or into the unit, unplug it immediately and call your local authorized Canon dealer or the Canon help line.
- The back of the FAX-L350 includes slots and openings for ventilation. To keep the FAX-L350 from overheating (which can cause it to operate abnormally and create a risk), take care not to block or cover these openings. Do not operate the unit on a bed, sofa, rug, or other similar soft surface, or near a radiator or other heat source. Do not place the FAX-L350 in a closet or cabinet or on shelves unless adequate ventilation is available. See "Choosing a Location for our FAX-L350" on page 1-25 for guidelines on how much space the unit needs for ventilation.
- Operate the FAX-L350 only from the type of power source indicated on the unit's label. If you are unsure of the type of power available from your wall outlets, contact your local power company.
- Make sure the total amperage used by all devices plugged into the wall outlet does not exceed the ampere rating of the outlet's circuit breaker.
- Do not allow anything to rest on the power cord or place the FAX-L350 where the cord will be walked on. Make sure the cord is not knotted or kinked.

Figure 1-12 Unit Cautions (1)

- ❑ Do not insert object of any kind into the slots or openings on the FAX-L350's cabinet, as they could touch dangerous voltage points or short out parts, and result in fire or electric shock.
- ❑ Do not allow small objects (such as pins, paper clips, or staples) to fall into the FAX-L350. If something does fall into it, unplug the unit immediately and call your local authorized Canon dealer or the Canon help line.
- ❑ Do not plug the power cord into an uninterruptible power supply (UPS).
- ❑ Always unplug the FAX-L350 before moving or cleaning it.
- ❑ Whenever you unplug the FAX-L350, wait at least five seconds before you plug it back in.
- ❑ Keep the FAX-L350 away from direct sunlight, as this can damage it. If you have to place it near a window, install heavy curtains or blinds.
- ❑ Do not expose the FAX-L350 to extreme temperature fluctuations. Install the unit in a place with temperatures between 50° and 90.5°F (10° and 32.5°C).
- ❑ Always unplug the FAX-L350 during thunderstorms.
- ❑ Before you transport the FAX-L350, remove the toner cartridge.
- ❑ Always lift the FAX-L350 as shown below. Never lift it by its multi-purpose tray or other supports.

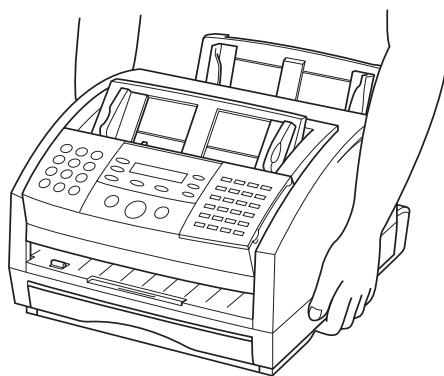

Figure 1-13 Unit Cautions (2)



Unplug the FAX-L350 and contact your local authorized Canon dealer or the Canon help line in any of these situations:

- If the power cord or plug is damaged or frayed.
 - If liquid spills into the unit, or if it is otherwise exposed to rain or liquids.
 - If you notice smoke or unusual noises or odour coming from it.
 - If the FAX-L350 does not operate normally when you follow the operating instructions. Adjust only those controls that are covered by the operating instructions in this user's guide, or you can damage the unit and require extensive repair work.
 - If the FAX-L350 is dropped or its cabinet damaged.
 - If the FAX-L350 begins performing poorly.
 - The optional handset emits low level electromagnetic waves. If you use a cardiac pacemaker and feel abnormalities, please move away from this product and consult your doctor.
-

Figure 1-14 Unit Cautions (3)

Choosing a Location for our FAX-L350

Before unpacking your FAX-L350, follow these guidelines to choose an appropriate location for the unit.



Please review the information provided in "Safety Instructions" on pages 1-22 to 1-24, to make sure you are installing your FAX-L350 for safe use.

- Put the FAX-L350 in a cool, dry, clean, well ventilated place:
 - Make sure the area is free from dust.
 - Make sure the location is not affected by extreme temperature fluctuations, and remains between 50° and 90.5°F (10° and 32.5°C).
 - Make sure the area's relative humidity is always between 20% and 80%.
- Keep the FAX-L350 away from direct sunlight.
- If possible, place the FAX-L350 near an existing telephone outlet, to allow for an easy connection of the telephone line to the unit.
- Place the FAX-L350 near an electrical wall outlet that provides 200 240 volt AC (50 60 Hz) power.
- Place the FAX-L350 near the PC you will be connecting it to. Make sure you can reach it easily, as you will be using the FAX-L350 as a printer, fax machine, copier, scanner, and telephone.
- Do not plug the FAX-L350 into the same circuit as an appliance such as an air conditioner, electric typewriter, television, or copier. Such devices generate electrical noise that can interfere with your unit's ability to send or receive faxes.
- Set the FAX-L350 on a stable, vibration-free surface that is strong enough to support its weight (about 28 lb/13 kg).

Figure 1-15 Unit Cautions (4)

Connecting the Power Cord



Follow these guidelines when connecting your FAX-L350 to a power source:

- ❑ The FAX-L350 is intended for domestic use only and requires 200–240V AC. Do not use it outside the country where it was purchased.
- ❑ Use only the power cord that came with the unit. Using a longer cord or extension cord can cause the FAX-L350 to malfunction.
- ❑ Unplug the unit only by pulling on the plug itself. Never pull on the cord.
- ❑ Do not plug the FAX-L350 into an outlet shared with an appliance such as an air conditioner, computer, electric typewriter, or copier. These devices generate electrical noise, which can interfere with the operation of the FAX-L350.
- ❑ Make sure nothing is laying on the power cord, and that the cord cannot be walked on or tripped over.
- ❑ Do not overload the electrical outlet. Make sure the total amperage used by all the machines plugged into the outlet does not exceed the ampere rating of the outlet's circuit breaker.
- ❑ Do not plug the unit into an uninterruptible power supply (UPS).

Figure 1-16 Unit Cautions (5)

Connect the power cord as follows:

1. Plug the supplied power cord into the power connector on the back of the FAX-L350.

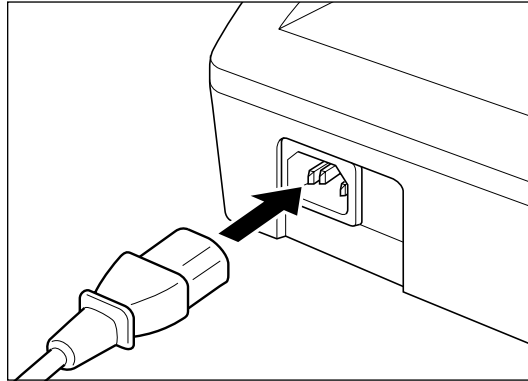

2. Plug the other end of the power cord into the outlet.



Note

The FAX-L350 has no power switch, so its power is on as long as it is plugged in. Once connected, though, the unit still needs to warm up before you can use it.

- While the FAX-L350 is warming up, the message PLEASE WAIT appears in the LCD display:

PLEASE WAIT

- When the date and receive mode appear, the FAX-L350 is in standby mode and ready for use:

31/12/1999 FRI 10:00
FaxOnly STANDARD



Note

If the toner cartridge has not been installed yet, the message CHECK COVER/CART alternates with the standby mode display:

CHECK COVER/CART

31/12/1999 FRI 10:00
FaxOnly STANDARD

Figure 1-17 Unit Cautions (6)

Making Connections

Connecting the FAX-L350 to Your PC

Your FAX-L350 has an 8-bit, bi-directional parallel interface port that allows you to connect it to a PC. To do this, you need to purchase a Centronics-compatible parallel interface cable from your dealer.



Note

For best results, use a cable that is no longer than 6.6 feet (2 meters). Canon recommends that you use a cable that complies with IEEE 1284. Contact your local authorized Canon dealer if you need help in selecting a cable.

Connect the FAX-L350 to your computer as follows:

1. Make sure the computer is turned off and the FAX-L350 is unplugged.
2. Connect the parallel interface cable to your FAX-L350:
 - a. Align the cable connector with the interface port so their shapes match.
 - b. Gently press the cable connector into the port.
 - c. Secure the cable connector by snapping both wire clips (on the sides of the port) into the cable connector, as shown below.

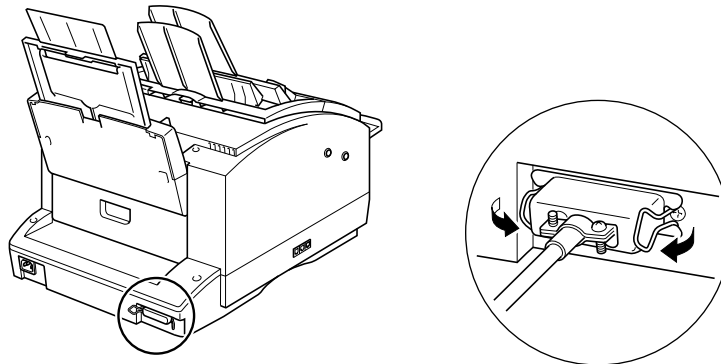

3. Connect the other end of the cable to the parallel interface port on your computer in the same manner.

Figure 1-18 Unit Cautions (7)

5.2.2 Toner cartridge cautions

a) Handling the toner cartridge

The Toner Cartridge

Handling and Storing Cartridges

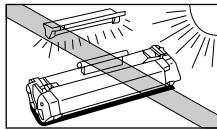

- ❑ Do not expose the cartridge to direct sunlight or bright light for longer than five minutes.

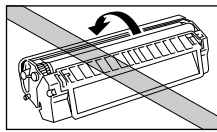

- ❑ Do not open the drum protective shutter on the cartridge. If the drum surface is exposed to light and damaged, print quality may deteriorate.

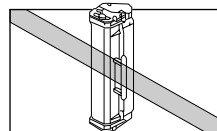

- ❑ Do not stand the cartridge on end, and do not turn it upside down. If toner becomes caked in the cartridge, it may prove impossible to free it even by shaking the cartridge.

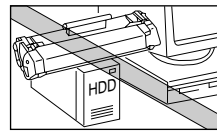

- ❑ Keep the cartridge away from computer screens, disk drives, and floppy disks. The magnet inside the cartridge may harm these items.

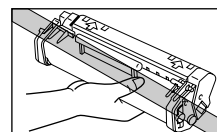

- ❑ Never touch the drum protective shutter. When holding the cartridge avoid touching the drum protective shutter with your hands.

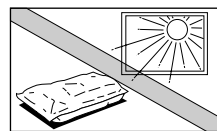

- ❑ Do not store the cartridge in direct sunlight.

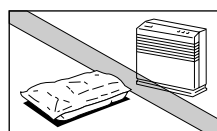

- ❑ Avoid locations subject to high temperature, high humidity, or rapid changes in temperature. Store the cartridge between 32° and 95° F (0° and 35° C).

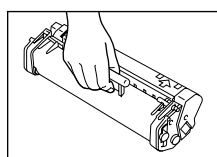

- ❑ Hold the cartridge as shown so that your hand is not touching the drum's protective shutter.

Figure 1-19 Precautions for Handling Cartridge (1)

b) Usage period of toner cartridge

The usage period for the toner cartridge is stamped on the label of its individual package. This period lasts for 2.5 years from the date of manufacture. Using a cartridge after this period may reduce print quality.

- ❑ Store the cartridge in its protective bag. Do not open the bag until you are ready to install the cartridge in the unit.
- ❑ Save the protective bag. You may need to repack and transport the cartridge at a later date.
- ❑ Do not store the cartridge in salty air or where there are corrosive gases such as from aerosol sprays.
- ❑ Do not remove the cartridge from the FAX-L350 unless necessary.



DO NOT PLACE THE CARTRIDGE IN FIRE. TONER POWDER IS FLAMMABLE.

Figure 1-20 Precautions for Handling Cartridge (2)

5.3 Servicing Cautions

5.3.1 Damage from static charge

This unit contains contact sensor and printed circuit boards equipped with ROM, RAM, custom chips, etc. These electronic components are susceptible to damage caused by static charge.

When disassembling this unit, take care to prevent static charge.



Static electricity

Electrostatic discharge damages electronic components and alters their electrical characteristics. Even plastic tools and hands without grounding wrist straps will generate enough static electricity to damage electronic components.

The following equipment is needed to prevent electrostatic discharge damage:

- A earthed conductive mat
- Grounding wrist straps
- A cord with alligator clips to ground this unit's metal chassis

If you do not have any of the above on hand (during on-site servicing), follow the alternate measures below:

- Use a grounding bag to store and transport printed circuit boards and electronic devices.
- Avoid wearing silk or polyester clothing and leather-soled shoes. Wear cotton clothing and rubber-soled shoes instead.
- Avoid servicing this unit in a carpeted room.
- Before servicing this unit, touch this unit's grounded terminals to discharge any static charge.
- Wear grounding wrist straps and ground this unit's metal chassis.
- Always handle the circuit boards and devices along their edges. Do not touch the components and terminals with your fingers.

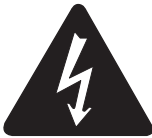

Electric shock when carrying out work with the fax turned on

When you must service the fax with the power cord plugged in, you must not ground your body with grounding wrist straps. This is to prevent electricity passing to your body and causing electric shock.

5.3.2 Scanner section

a) Contact sensor

- Handle contact sensors with care to prevent scratching or smudging of the scanning surface. Scratches or smudges can cause vertical stripes, etc., to appear on the scanned image.

b) ADF rollers

- Be careful not to scratch the ADF rollers. If the rollers are scratched, paper jams may result.

c) Lubrication points

- Document feed roller.

5.3.3 Printer section

a) Transfer charging roller

If skin, oil or, the like, gets on the sponge of the transfer charging roller, the rear side of the recording paper can be soiled, and blank patches can occur in printing.

During disassembly, hold the transfer charging roller by the shaft and gears at both ends.



REFERENCE

Cleaning method

If a printing defects occur, clean the transfer charging roller, as explained in *Chapter 3: Maintenance & Service*.

b) Fixing ass'y

If you get skin, oil, or the like, on the internal fixing film or pressure roller surface, the front or rear of the recording paper may be soiled, and fixing defects, and jams can occur.

During disassembly, hold the fixing ass'y by the plastic sections. Hold the pressure roller by the shaft, at both ends of the rollers.



REFERENCE

Cleaning method

If the fixing film or pressure roller is soiled, clean the transfer charging roller, as explained in *Chapter 3: Maintenance & Service*.

c) Lubrication points

Do not touch the greased parts of the outer periphery of the gear shaft and the gear teeth at the left side of the main frame. If you do, the grease (applied for smooth operation of the printer mechanism) will come off.



Use only specified grease.

If you use other grease, the grease may oxidize, and weaken plastic parts.



REFERENCE

If you accidentally touch a greased part and grease comes off, reapply the grease, *see the PARTS CATALOG (supplied separately)*.

d) LASER/Scanner unit

The LASER/scanner unit cannot be adjusted in the field so do not attempt to disassemble it. Never loosen or remove the screws on the LASER/scanner unit. Doing so might prevent satisfactory printing.

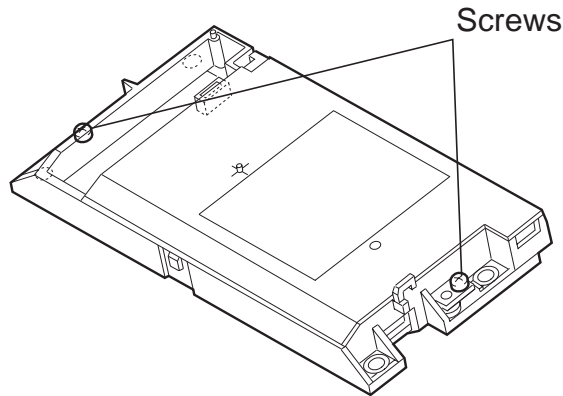
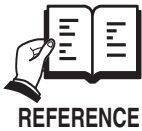

Figure 1-21 Precaution for Handling LASER/scanner Unit

5.3.4 Paper feed section

a) Pick-up roller

If, skin, oil or, the like, gets on the pick-up roller surface, misfeeding, jam, or multi-feeding can occur. During disassembly, hold the pick-up roller by the plastic sections.



Cleaning method

If the printing defects occur, clean the pick-up roller, as explained in *Chapter 3: Maintenance & Service*.

5.3.5 Paper load section

b) Lifting arm position

If cassette is removed with the lifting arm raised to clear jam, the cassette cannot be inserted again. If the recording paper cassette is inserted forcibly, the arm may be damaged. To initialize the lifting arm position (move the arm down), turn the power off and on again or

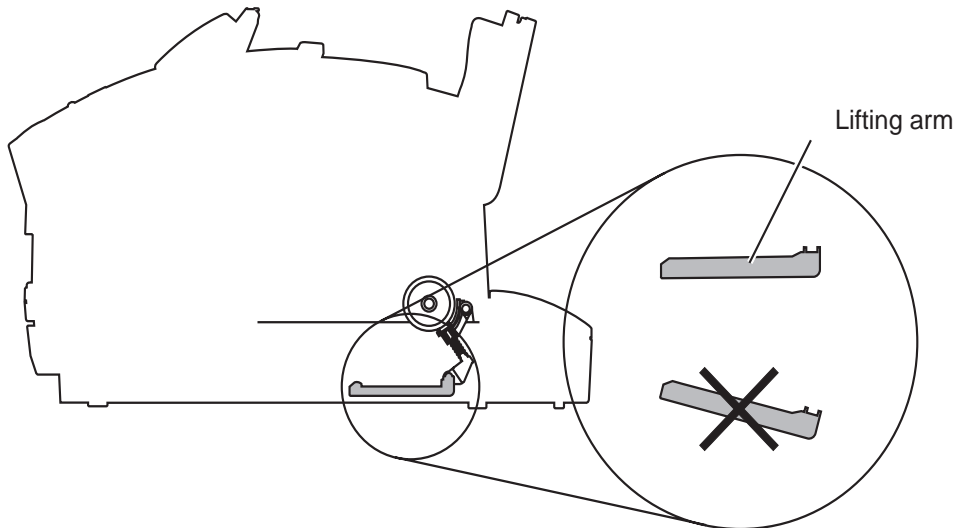

Figure 1-22 Lifting arm position

5.3.6 Control boards

a) SCNT board

- The SCNT board stores the user data, service data, and other data. Therefore, when replacing the SCNT board, print out the stored data and then enter this data into the new SCNT board.



The SCNT board replacement precaution is described in “5.4.3 SCNT board replacement precautions” on Page 1-39.

REFERENCE

- The SCNT board’s volume resistor VR1 has been factory-adjusted. Service personnel are not to alter its setting.

b) Power supply unit

- Current fuses FU101 on the power supply unit are directly attached. If these fuses must be replaced, we recommend replacing them together with the power supply unit.
- The power supply unit’s adjustable volume VR201, VR202 has been factory-adjusted. Service personnel are not to alter its setting.



Do not plug the unit into an uninterruptible power supply (UPS).
Doing so may result in damage to the fixing ass’y.

5.3.7 Replacing ROM

Observe the following precautions when replacing the ROM on the SCNT board, for example, when replacing a defective ROM.

a) Preparation

Print out all battery backed up data.



Reception image data in image memory is erased approx. one hour after power is turned off.

b) Replacement

- (1) Make sure that the power cord is disconnected.
- (2) Put on the grounding wrist straps to counter electrostatic discharge.
- (3) Open the operation cover, remove the 1 screw on the inner cover, and remove the ROM cover referring to the *"Parts catalog"* (supplied separately).
- (4) Remove the ROM mounted on the SCNT board using the ROM extractor etc.
- (5) Insert the new ROM, making sure that the notches on the ROM package and IC socket are aligned.

c) After replacement

- (1) When a defective ROM is being replaced with a new ROM, turn the power on after mounting on the SCNT board. This completes replacement.
- (2) When the ROM is replaced for upgrading the software and upgrading involves changing software switch settings such as service data, you must perform the following operation.
 - Perform All Clear operation. After you perform All clear operation, register the backed up data referring the list you printed out earlier.

5.4 Data-related precautions

The memory IC on the circuit board stores the user's registration data and values for various counters, etc., required for servicing. Although this data is normally retained in memory, it can be deleted by mistake. When handling this data during servicing, note the following precautions.

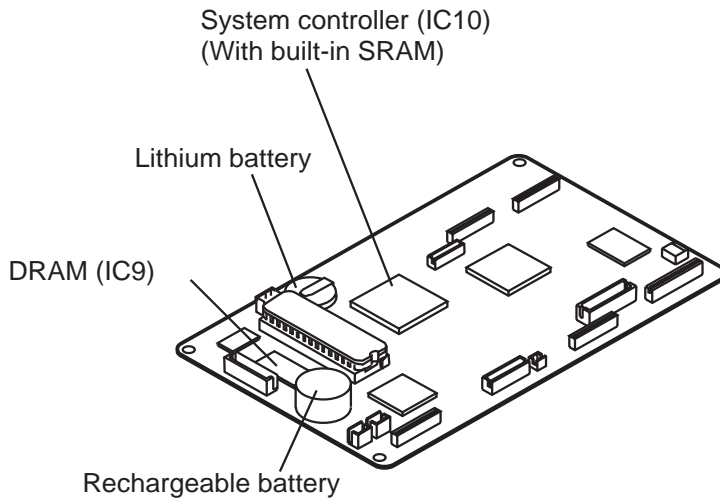

Figure 1-23 Backed up Devices

5.4.1 Data in the image storage memory (DRAM)

DRAM stores image data which was read other than by a direct transmission. It also acts as a buffer memory to store the image data received. Transmitted and reception image data stored in the DRAM, on the SCNT board, are backed up for approx. one hour by electric double layer capacitor.



NOTE

Reception image data

When image data are set to be printed, they will be stored in the DRAM as memory reception images, and "RECEIVED IN MEMORY" will be displayed. If printing is disabled due to a fault in the printing section, transfer the stored reception image data to another fax machine.



NOTE

Reception image data transfer

When reception images cannot be output due to printer failure, etc., the image data can be transferred to another fax machine by using the reception image data transfer function.

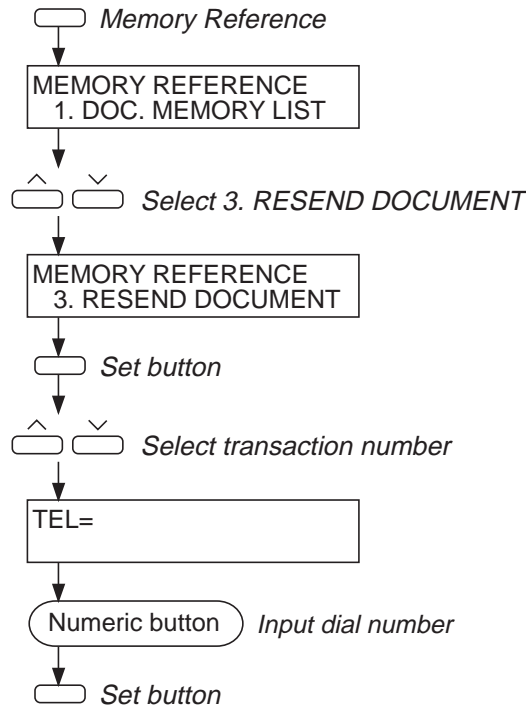

Figure 1-24 Reception Image Data Transfer

5.4.2 Data in the control processing memory (SRAM)

SRAM is backed up by a lithium battery. It can retain the stored data for 5 years after the power is turned off. SRAM stores the following data: All the data the user entered with the user data setting, the activity reports and other report-generating data, the redial data containing the redial destinations set with the Redial button, the servicing data set by repair personnel with the service soft switch. SRAM stores almost all of the data which can be entered or set.

These stored data can be checked with various reports.



NOTE

Jumper plug precautions

The control/image processing memory is backed up by shorting the jumper pin (JP1) on the SCNT board with the jumper plug. If the jumper plug is removed and the power is turned off, the data in SRAM will be lost.

Before removing the jumper plug, be sure to print out the data stored in the SRAM.

Lithium battery life

The lithium battery can last for over 5 years after the power is turned off.

When the power is on, the lithium battery's power is untapped. Therefore, the actual battery life can be much longer.

When the lithium battery becomes exhausted, "**DATA ERROR**" will be displayed after the power is turned off or on. When this happens, replace the lithium battery. Since the data in SRAM will be lost when the battery is replaced, it cannot be printed out.

After the lithium battery is replaced and the power is turned on, "**DATA ERROR**" will be displayed. Press the *Set* button to discard the contents in SRAM and initialize it to the factory defaults.

5.4.3 SCNT board replacement precautions

Before replacing the SCNT board, print out all of the stored data.

The list which output the data that must be entered into the new SCNT board is listed below.

User list

- One-touch speed dialing list
- Coded speed dialing list
- Group dialing list
- User data list
- Activity report

Service list

- System data list
- System dump list



REFERENCE

To printout these list, see *Chapter 3: 7. SERVICE REPORT on Page 3-65.*



The service part SCNT board uses a jumper pin to close the lithium battery's circuit. To prevent battery depletion during shipping, only one prong of the jumper pin is covered with a jumper plug.

When replacing the SCNT board, re-attach the jumper plug so that it covers both prongs of the jumper pin and closes the circuit; the lithium battery can then be used for SRAM back-up.

If this procedure is omitted, there will be no battery back-up for the SRAM data.

After the new SCNT board is installed and the power is turned on, "**DATA ERROR**" will be displayed. Press the **Set** button to discard the SRAM's irregular contents and initialize it to the factory defaults.

Then refer to the list that was printed out beforehand and enter the various data.

5.4.4 Data initialization through service operation

All the data can be initialized with the service data #8 clear operation.



REFERENCE

For details on the initialization procedure and the data that is erased, see Chapter 3: 5.2 Service Data Settings on Page 3-28.



NOTE

"All clear" when nothing works.

On a rare occasion, the display may go blank and all the buttons may stop working. Severe electrical noise and static can cause problems as well. In such a case, use the "All clear" feature.

After installing the unit for the first time and connecting the power cord, execute "All clear".

Also, after an "All clear", we recommend that you set the country type to suit the communication standard used in your country. Below is the procedure for performing All clear and type setting operation.

ALL CLEAR

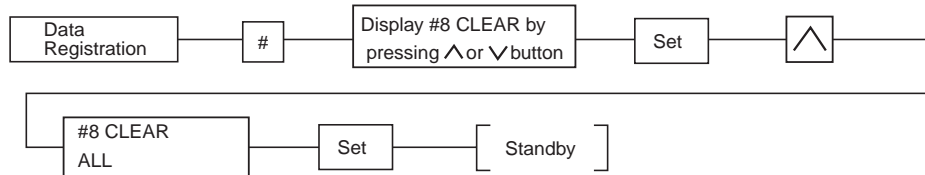

TYPE SETTING

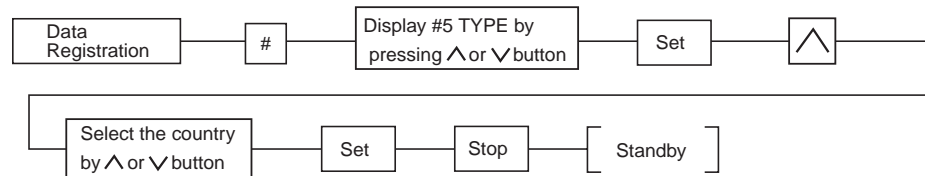

Figure 1-25 All Clear and Type Setting

5.5 Protective Mechanism

5.5.1 Data battery backup function

If there is a power outage or if the power is turned off, the data stored in the control memory is retained since the lithium battery function as a data battery backup.



For details on the backed up data, see Chapter 1: 5.4 Data-related precautions on Page 1-36.

REFERENCE

5.5.2 Overcurrent protection

This machine is provided with an overcurrent with built-in fuse, to prevent abnormal rises in temperature if an overcurrent flows to the motors and power supply due to driver IC trouble, software lockup and short circuit.

Protected Parts	Safety Measures
Document feed motor	IC protector (FU501) on SCNT board
Main motor	IC protector (FU501) on SCNT board
Power supply unit	Glass-tube current fuse (FU101:250V, 3.15A) overcurrent protection circuit thermistor (TH101)
Fixing ass'y	Thermal fuse, thermistor

5.5.3 Lightning protection

The fax unit's electrical components are protected from abnormal voltage caused by lightning.

Protected Component	Safety Device
NCU board ass'y	Arrester (AR1, AR2) located at the primary side of the NCU board discharge a voltage of more than 500VDC via the power cord.
Power supply unit	Varistor (VZ101, VZ102*) and arrester (AR101)* located at the primary side of the power supply unit discharge a voltage of more than * For VZ102 and AR101, only the AE version exists.



NOTE

When protection is not possible

The NCU board sometimes may not be protected even by the protection circuits if lightning strikes the telephone line.

5.5.4 Power leakage protection

The AC line, telephone line, and metal parts of the fax unit are completely insulated. The fax unit has a grounded power cord to prevent electrical shock. If power leakage does occur, use the fax unit only with a grounded electrical outlet supplying the proper voltage.

6. QUALIFICATION REQUIRED FOR INSTALLATION WORK

The qualifications for installation must satisfy local laws and regulations.

Chapter 2

Technical Reference

1. DRIVE/ELECTRICAL SYSTEM LAYOUT

This machine is divided into three mechanisms: scanner section, paper supply section and printer section. In the scanner section, the document feed motor drives the document feed rollers and separation rollers to feed the document from the document feed tray to the document eject slot at the front of the machine. The document is scanned by the contact sensor located along the document feed path.

In the paper supply section, the main motor in the printer section is used to drive the paper pickup roller, which separates one sheet at a time from multiple sheets set in the cassette at the bottom of the machine or set on the recording paper rest at the rear of the machine, and feeds the recording paper to the printer section.

In the printer section, the main motor drives the gears and rollers to print the image scanned from the document onto the recording paper fed from the papers supply section, which is then ejected. The user can choose to eject the printed paper either face up or face down.

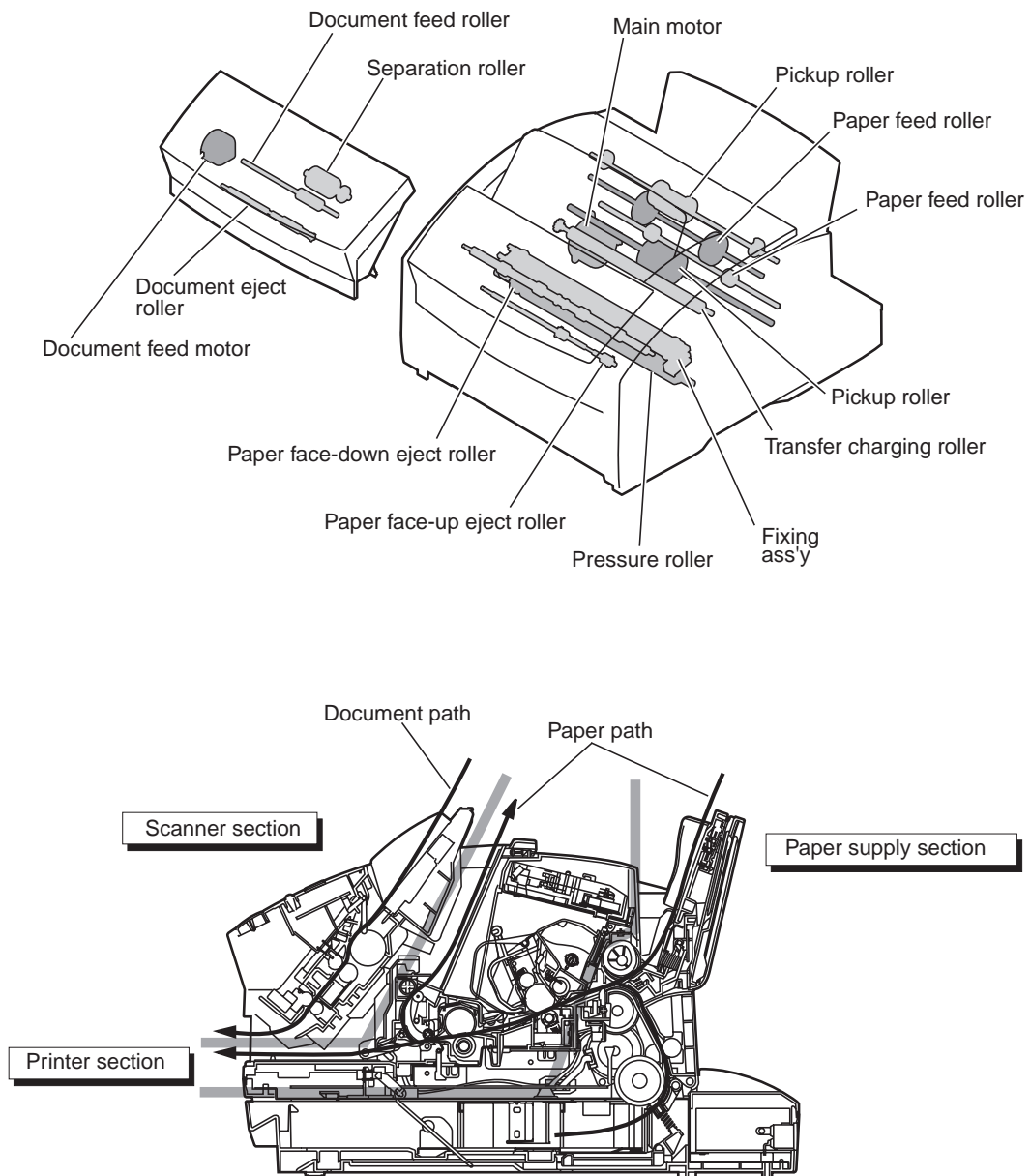

Figure 2-1 Drive System Layout

The following eight printed circuit boards are located in this machine:

- SCNT board that controls the entire system
- NCU board that interfaces with the telephone line
- MODULAR board that connects the telephone line and the NCU board
- PCNT board that generates high voltage for the printer
- OPCNT board that controls the operation panel's buttons and LCD.
- A power supply unit is also located in this machine.
- MCNT board that controls the main motor.
- INTERFACE board that interfaces with the PC.

The nine sensors shown below detect the status of the machine.

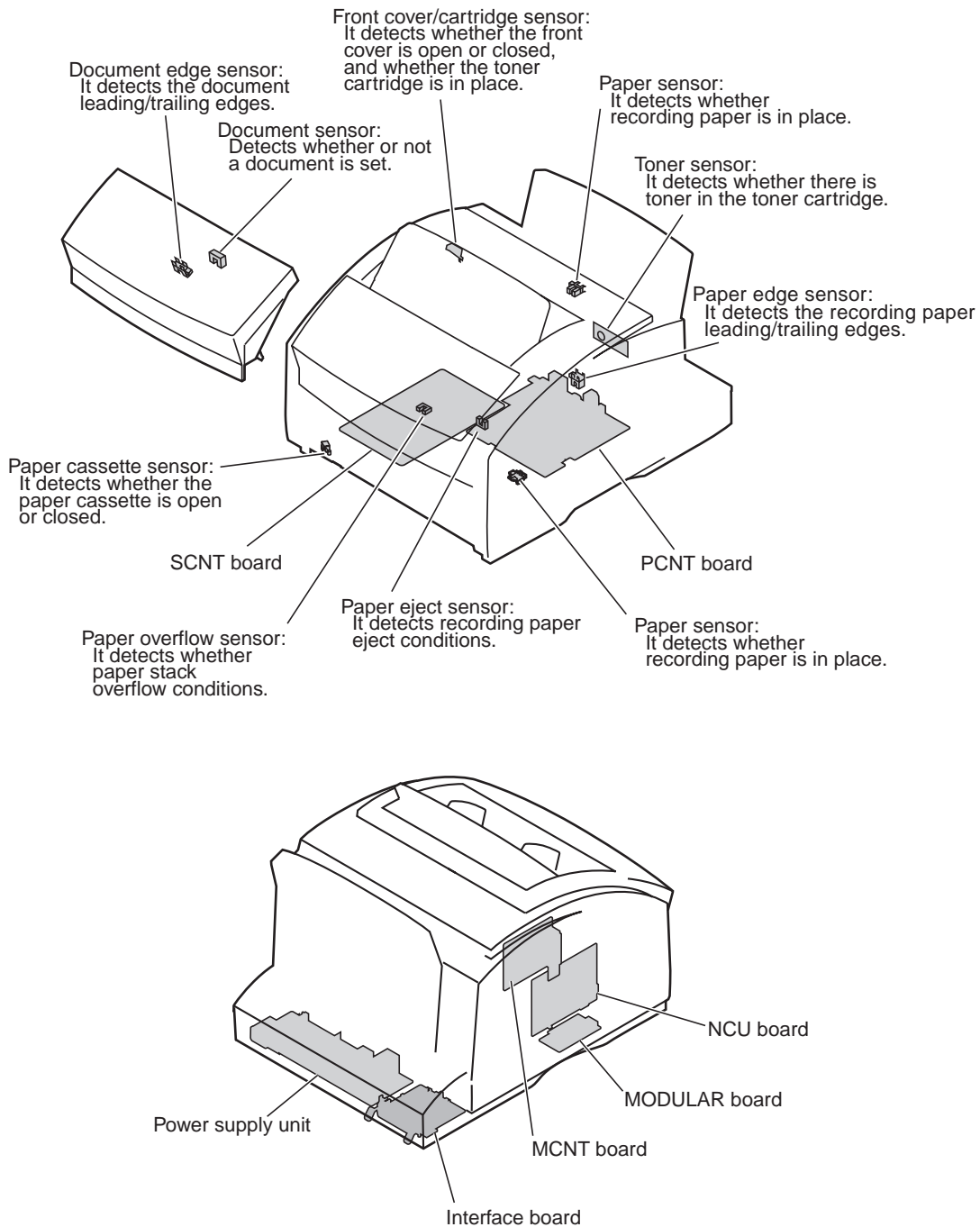

Figure 2-2 Electrical System Layout

This page intentionally left blank

2. SCANNER MECHANISM

The scanner section scans documents that are to be sent or copied.

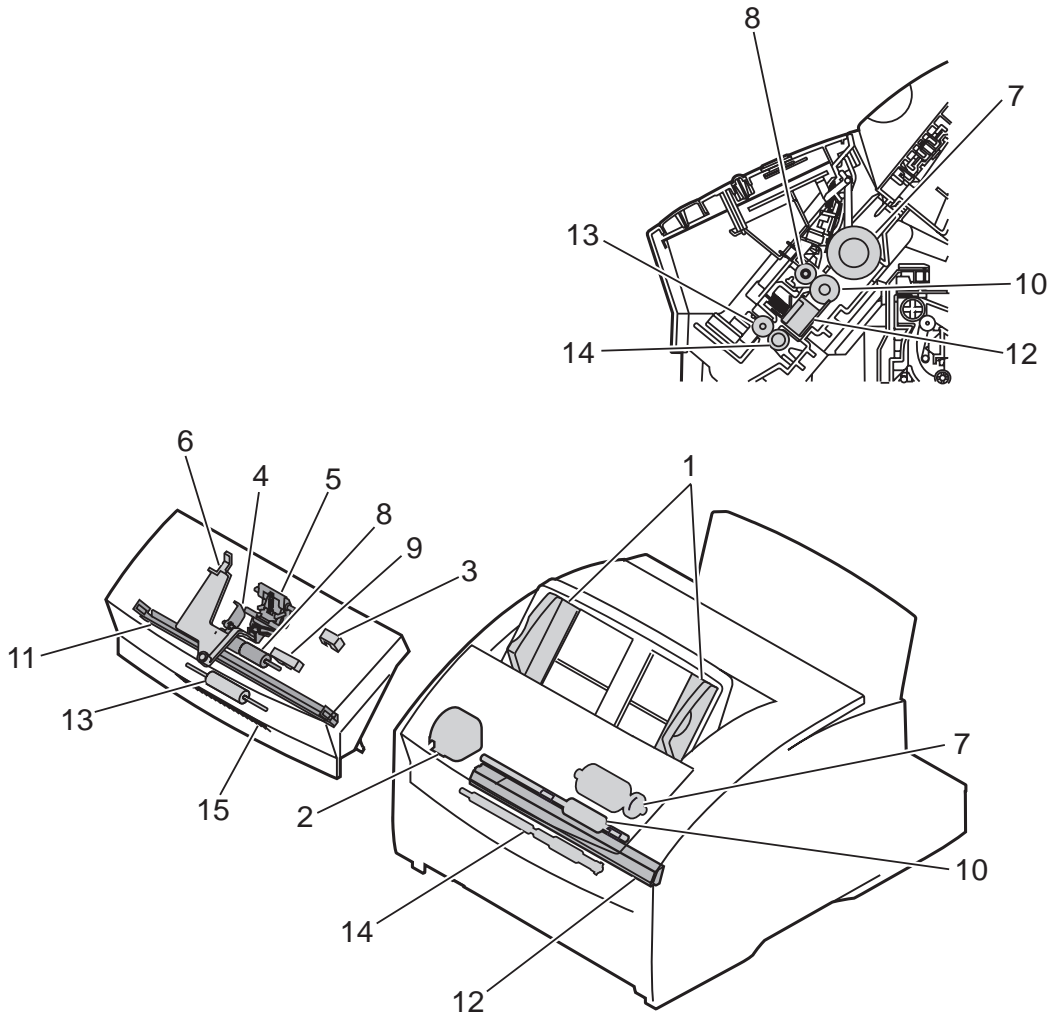

Figure 2-3 Scanner Section

Names and functions of parts:

1. Paper Guide

When properly adjusted to the width of the documents, the guide will hold the documents in the horizontal direction to prevent them from skewing when fed.

2. Document Feed Motor

This motor drives all the rollers in the scanner section.

3. Document Sensor (DS)

This sensor uses an actuator to detect the presence of documents to be scanned, and sends that information to the SCNT board by way of the gate array in the operation panel unit.

4. Document Stopper

This stopper is located to the side of the separation rollers, and prevents documents from entering too far inside the scanning section. This stopper is located here to improve document loading and prevent double feeding or non-feeding due to defective loading of documents.

5. Separation Guide

Separates the documents to prevent double-feeding.

6. Document Feed Lever

This lever switches between automatic document feed and manual document feed. Damage to the document caused by the separation roller can be minimized by switching to the manual document feed position when sending single sheets such as thick-stock paper or photographs.

7. Separation Roller

This roller uses differences in the coefficients of friction of the separation guide, document and separation roller to separate each of the sheets in a multiple-page document.

8. Upper Document Feed Roller

When the separation roller starts to rotate, the upper document feed roller raises the document stopper so that documents can be fed.

9. Document Edge Sensor (DES)

Using an actuator, the DES detects the edge of a document just before it reaches the contact sensor, and sends this information to the SCNT board.

10. Document Feed Roller

This roller feeds documents to the contact sensor after they are separated by the separation roller.

11. White Sheet

This white sheet is used as a whiteness reference when pre-scanning documents.

12. Contact Sensor

Scans the image information from the document, converts it to serial data, and transmits it to the SCNT board as an electrical signal. The contact sensor has a scanning resolution of 300 dpi.

13. Upper Document Eject Roller

Holds the document between the document eject rollers, and then ejects it.

14. Document Eject Roller

This roller ejects documents fed from the document feed roller.

15. Static Eliminator Brush

Removes static electricity which may have built up on the document in the scanning process, and guards against roller jams.



NOTE

Initializing the upper document feed roller

When the separation roller starts to rotate, the position of the upper document feed roller is simultaneously initialized to raise the document stopper. Initialization is carried out when the power is turned ON, when documents are inserted and when documents are ejected.

Document feed lever

Switching between automatic document feed and manual document feed is carried out by the document feed lever above the left side of the LCD. During automatic document feed, documents are gripped between the separation guide and the separation roller. Switching the lever to manual document feed raises the separation guide and frees it from the document. Manual document feed can therefore minimize the possibility of damage caused by pinching between the separation guide and separation roller when feeding documents such as thick-stock paper or photographs. However, because document separation does not occur in manual document feed mode, only one sheet at a time may be loaded. Loading multiple sheets will result in double feed.

Document Jam Detection

There are two types of document jams which may occur:

a) Feed jam

Occurs when the document edge sensor cannot detect the document's leading edge within 15 seconds after the start of document separation.

b) Eject jam/document too long

Occurs when the document edge sensor cannot detect the document's trailing edge within one meter of feeding after the document's leading edge is detected.

When one of these types of jams occurs, all data which have been read and stored in memory (except pages that have already been completely transmitted or copied) are erased.

This page intentionally left blank

3. PAPER SUPPLY SECTION

The paper supply section separates the sheets of recording paper loaded in the sheet feeder and feeds them to the printer section one sheet at a time.

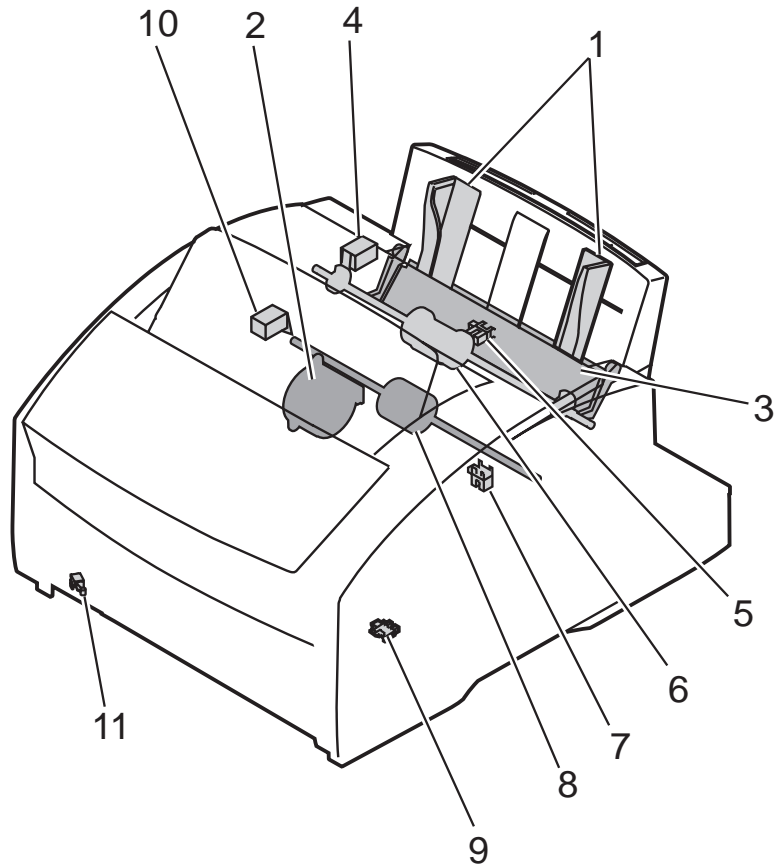

Figure 2-4 Paper Supply Section

Names and functions of parts:

1. Paper Guide (MULTI-PURPOSE TRAY)

This guide can be adjusted to the width of the loadable recording paper sizes. It prevents the recording paper from skewing during recording by accurately aligning the paper width.

2. Main Motor

This motor drives all the rollers in the paper supply section.

3. Lifting Plate

The lifting plate that was held down by the pickup roller is lifted up during paper feeding, and the recording paper loaded on the lifting plate contacts the pickup roller to be separated.

4. Pickup Solenoid

This solenoid controls rotation of the pickup roller. When the main motor is activated to begin paper feeding, the pickup solenoid releases the pickup roller. When the pickup roller picks up a sheet of recording paper and rotates one full turn, the solenoid locks the pickup roller again.

5. Paper Sensor (PS)

This sensor uses an actuator to detect the presence of recording paper in the sheet feeder.

6. Pickup Roller

The pickup roller is rotated once, and operating together with the lifting plate, feeds the paper one sheet at a time.

7. Paper Edge Sensor (PES)

This sensor uses an actuator to detect the leading edge of recording paper and sends detection information to the SCNT board. It is located under the pickup roller.

8. Pickup Roller

The pickup roller is rotated once, and operating together with the lifting plate, feeds the paper one sheet at a time.

9. Paper Sensor

The sensor detects the presence/absence of recording paper inside the cassette.

10. Pickup solenoid

This solenoid controls rotation of the pickup roller. When the main motor is activated to begin paper feeding, the pickup solenoid releases the pickup roller. When the pickup roller picks up a sheet of recording paper and rotates one full turn, the solenoid locks the pickup roller again.

11. Paper cassette sensor

The sensor detects the presence/absence of the paper cassette.



NOTE

Paper Feed Jam Detection Retry Function

Because the recording paper on this machine is loaded upright, the paper is sometimes difficult to feed when there is little recording paper left or the recording paper curls. For this reason even if the paper edge sensor does not detect the leading edge of the recording paper within a specific time* after the pickup solenoid releases the pickup roller the machine tries to repeat the same operation before judging that a jam has occurred. If the paper edge sensor still cannot detect the leading edge of the recording paper, a paper feed delay jam is detected.

* Within 3.5 sec. in the case of the Multi-purpose tray.

Within 8 sec. in the case of the cassette.

Initializing the lifting arm

If the cassette is removed to clear jams with the fixing arm raised, the cassette cannot be inserted again. If the cassette is inserted forcibly, the arm may be damaged. To initialize the lifting arm position (move the arm down), with the toner cartridge installed turn the power off and on again or open and close the printer door or front cover, then, insert the cassette.



NOTE

Paper feed jam detection

There are two types of paper jam which may occur:

a) Paper feed delay jam

The paper feed delay jam occurs if the paper edge sensor does not detect the leading edge of the recording paper within a specific time* (including paper feed jam detection retry time) after the pickup solenoid releases the pickup roller.

* Within 3.5 sec. in the case of the Multi-purpose tray.

Within 8 sec. in the case of the Cassette.

b) Paper feed stationary jam

The paper feed stationary jam occurs if the trailing edge of the recording paper is not detected within 11.7 seconds after the paper edge sensor detects the leading edge of the recording paper.

When either of these jams is detected, the message “**CLEAR PAPER JAM**” is displayed. If this machine is receiving, the data is received via memory reception. If the machine is copying from memory, the image data in memory will be cleared.

To clear a paper feed jam, open the front cover and remove the jammed recording paper from inside. When the front cover is closed, the recording paper is automatically output. When jammed recording paper is removed from inside without opening the front cover, open and close the front cover once to reset the printer.

Paper size error

The machine does not have a paper size sensor. It recognizes the paper sizes (Letter, A4, and Legal) according to the User setting.

A paper size error occurs if the specified paper size is different from the size of the paper placed in the sheet feeder when one page is actually printed. In this case, a message “**CHECK PAPER SIZE**” appears on the display, the ALARM lamp blinks, and the following operation is carried out.

If the specified paper length is greater than the actual paper length:

When the received document comprises one page, one sheet is printed and operation ends. The error message remains displayed, so clear the error message. When the received document comprises two or more pages, it is received in memory from the second sheet onward. Printing automatically starts from the 2nd sheet onwards after the error is corrected.

If the specified paper length is less than the actual paper length:

Regardless of whether the document consists of only one sheet or two or more sheets, it will be received in memory.

The document is automatically output after the error is corrected.

To correct the error, match actual recording paper with the User setting.

In this case of direct copying, a “**check paper size**” will not occur even if the size is different from that of the recording paper as long as the pickup is from the multi-purpose tray; if the pickup is from the cassette, however, a “**check paper size**” will occur.

In the case of memory copying, on the other hand, a “**check paper size**” will occur if the size is different from that of the recording paper when pickup is from either the cassette or the multi-purpose tray.

This page intentionally left blank

4. PRINTER SECTION

The LASER beam printer engine comprises the following sections.

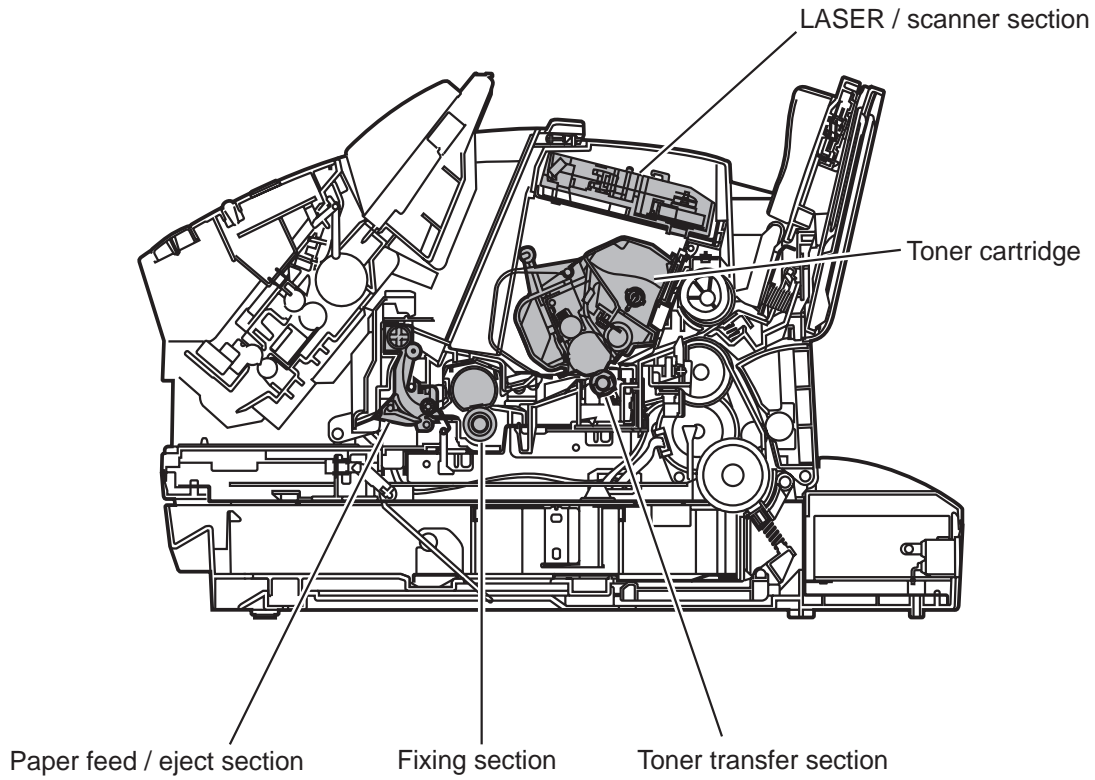

Figure 2-5 Printer Section

4.1 LASER/Scanner Section

This section comprises a LASER unit, cylindrical lens, 4-faced polygon mirror, scanner motor, imaging lens, reflection mirror and BD unit. The LASER is driven in accordance with the LASER drive signals that are sent from the PCNT board. This LASER light passes through the cylindrical lens to fall on the 4-faced polygon mirror that is rotating at a fixed speed. The LASER light is reflected from the 4-faced polygon mirror and passes through the imaging lens, and reflects from the reflection mirror to scan the photosensitive drum in the toner cartridge.

4.2 Toner Cartridge

This cartridge comprises the primary charging roller, developing cylinder, photosensitive drum, cleaner blade, and toner.

The LASER beam from the LASER/scanner section forms a latent static image on the photosensitive drum that is charged by the primary charging roller. The photosensitive drum rotates inside the toner cartridge, and rotation of the developing cylinder causes toner to adhere to the photosensitive drum to form a visible image which is then transferred to the recording paper at the toner transfer section. Residual toner is then removed from the surface of the photosensitive drum by the cleaning blade.

4.3 Toner Transfer Section

This section comprises the transfer charging roller and the static eliminator. The recording paper passes between the photosensitive drum and the transfer charging roller, and the transfer charging roller is charged with a charge opposite to that of the toner to transfer the toner on the photosensitive drum to the recording paper. The charge on the rear side of the recording paper is then removed by the static eliminator.

4.4 Fixing Section

This section comprises the fixing ass'y and pressure roller. The fixing section on this machine is an on-demand system that uses fixing film with low thermal capacity.

The toner that was transferred to the recording paper at the toner transfer section is fused to the paper and fixed as a permanent image.

The fixing ass'y has a built-in fixing heater and thermistor. The fixing temperature is controlled by the printer controller on the SCNT board.

4.5 Paper Feed/Eject Section

After toner is fixed in the fixing section, the recording paper is fed to either the face-up delivery slot or the face-down delivery slot that is switched by the flapper. The user selects the setting of the flapper by the paper delivery selector at the bottom left of the front panel.

All rollers from paper feed through paper ejection are driven by the main motor.

1. Paper eject sensor

An actuator is used to detect the leading edge of the recording paper that is fed towards the ejected paper. The detection information is sent to the SCNT board.

2. Flapper

This flapper switches the direction in which the recording paper is ejected after toner is fixed.

3. Paper overflow detection

The paper overflow sensor on the face-down paper eject cover detects paper stack overflow in the face-down delivery slot during face-down output.



NOTE

BD Malfunction

If the total number of sheets printed after turning the power ON is four or more, and BD is out of the BD cycle for 2.0 seconds or more during laser drive while the scanner motor is rotating at fixed speed, the printer controller judges this to be a BD malfunction.

Scanner Motor Malfunction

If the predetermined speed of rotation is not reached within 3.0 seconds of start of scanner motor rotation, the printer controller detects a scanner motor malfunction and stops the scanner motor.



The LASER/scanner unit contains parts that require adjustment that must be adjusted.
Never disassemble the LASER/scanner.



NOTE

No-toner detection

The no-toner state is detected by the toner sensor (magnetic sensor) located on the pickup roller shaft. If a toner cartridge is installed, the toner sensor touches the side of the cartridge. The part of the cartridge which the toner sensor touches is made thinner to increase the sensor output. When the toner sensor detects no toner, the sensor output goes low.

Cartridge detection

A microswitch detects cartridge presence and front cover open/closed. The microswitch is structured so that it is shorted only when the cartridge is loaded and the front cover is closed.



Drum cover shutter

If the photosensitive drum is subjected to strong light, optical memory can cause dropout areas or black bands to occur. To prevent the photosensitive drum from strong light, a drum cover shutter is attached. Do not open this cover unless absolutely necessary.



NOTE

Fixing Heater Malfunction

The printer controller on the SCNT board detects a fixing heater malfunction in the following instances.

- a) When a temperature of 100°C or more is not detected within 15 seconds after the fixing heater begins heating toward the normal preset target temperature.
- b) When a fixing unit temperature of 195°C or more continues for 150m seconds.
- c) When a temperature of 20°C or more is not detected even though the power is supplied for 0.5 seconds during printing or warming up.
- d) When a temperature of less than 0°C is detected for 150m seconds during fixing heater control.
- e) When the fixing heater temperature falls to 90°C or lower for 3 seconds during printing.

When a fixing heater malfunction is detected, this machine shuts off the power supply to the fixing heater, stops the main motor, scanner motor and high-voltage systems, and generates a printer error.

Paper eject jam detection

There are two types of paper eject jam which may occur.

a) Paper eject stationary jam

A paper eject stationary jam occurs when the paper eject sensor detects the paper between 3.3 and 4.7 seconds after the paper edge sensor detects the trailing edge of the paper.

b) Paper eject delay jam

A paper eject delay jam occurs if the paper eject sensor detects “no paper” between about 5 seconds after the paper edge sensor detects the leading edge of the paper and about 2.5 seconds after paper edge sensor detects the trailing edge of the paper. Fixing unit windup jams are also detected by this method.

When either of these jams are detected, “**CLEAR PAPER JAM**” is displayed. If the jam occurs during reception, the data is received in memory. If it occurs in memory copy mode, the image data in memory is cleared.

To clear a paper eject jam, open the front cover, and remove the jammed paper. Output resumes automatically when you close the front cover. If you remove the jammed paper without opening the front cover, open and close the front cover once to reset the printer.

When a fixing unit windup jam occurs, remove the delivery cover to access the jammed paper, then remove the jam.

Paper delivery slot switching

The paper delivery slot can be switched by the paper delivery selector located at the bottom left on the front of the machine. After fixing, the paper is fed to the flapper, which guides it to one of two delivery slots. When the paper delivery selector is set to the up position, the flapper is lowered to guide paper to the face-down delivery slot. The paper is delivered face-down, so that pages are stacked in numeric order.

When the paper delivery selector is set to the down position, the flapper is raised to guide paper to the face-up delivery slot.

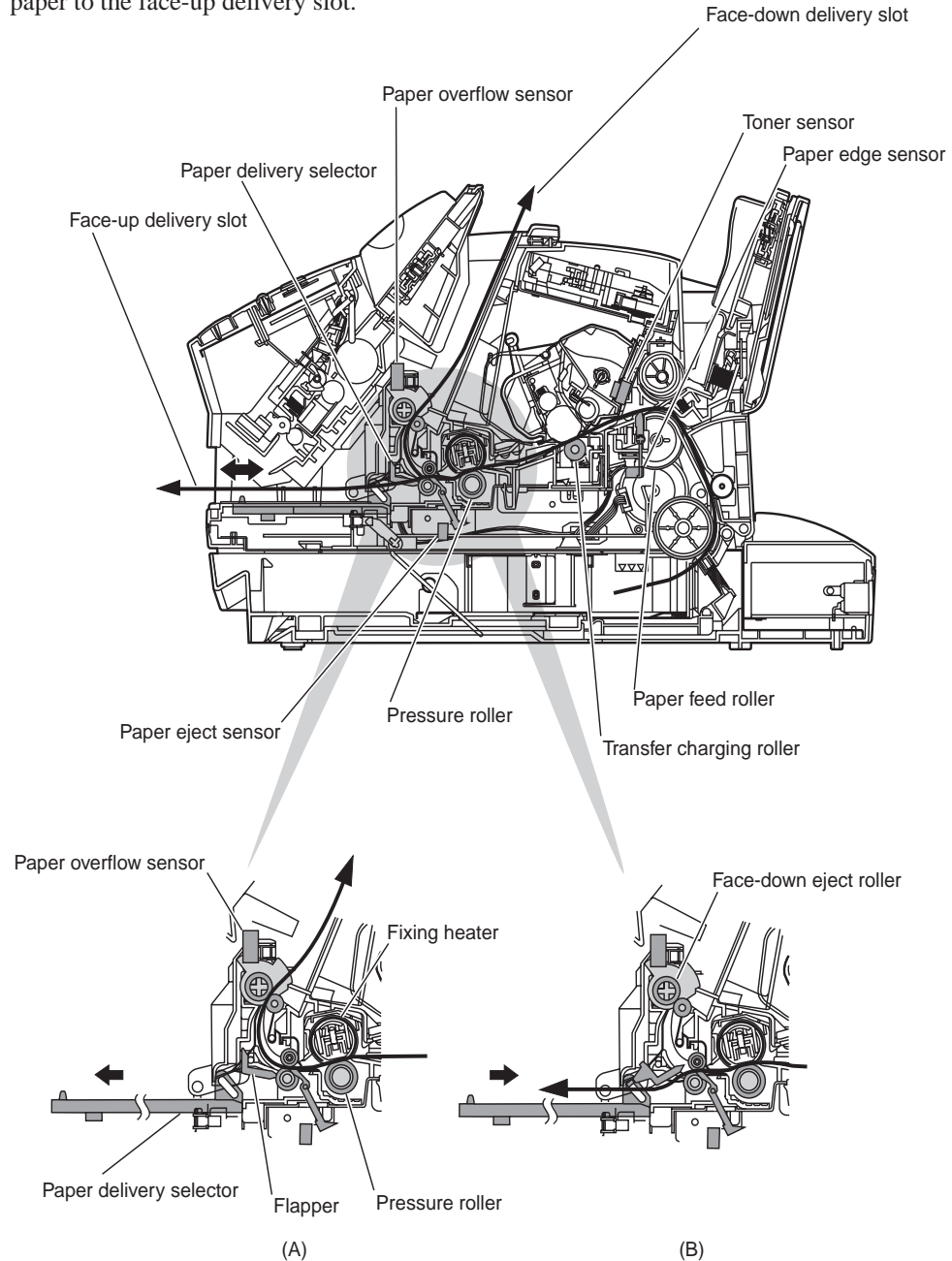

Figure 2-6 Paper Delivery Slot Switching



Paper delivery

Always be sure to use the face-up delivery slot when recording onto envelopes, label paper or transparencies. Using the face-down slot can result cause jams and damage the recording medium.

5. ELECTRIC CIRCUIT

5.1 Component Block Diagram

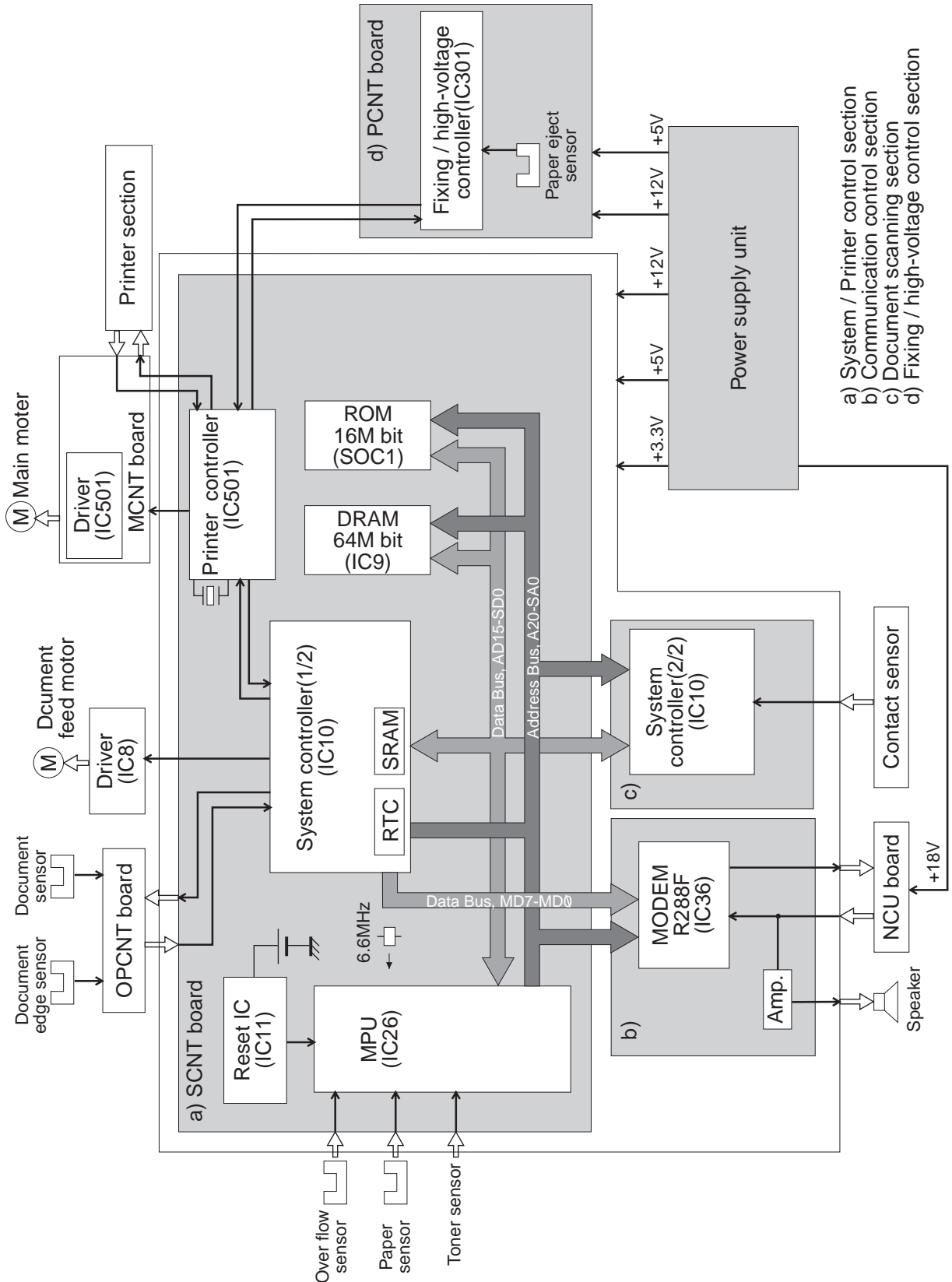

- a) System / Printer control section
- b) Communication control section
- c) Document scanning section
- d) Fixing / high-voltage control section

Figure 2-7 Block Diagram

5.2 Circuit Board Components

a) System control section

The system controller is made up of the following components, and controls the entire fax system.

a-1) MPU (Micro Processor Unit) (IC26)

The main functions of the NEC μ PD703102GJ-A33 MPU are as follows:

- 32 bit CPU
- 16 bit address bus
- 16 bit data bus
- DMA control
- A/D converter
- Software CODEC
- Interrupt control unit

a-2) System controller (IC10)

The system controller is a gate array for controlling MPU peripheral devices. The main functions of the system controller are as follows:

- Printer resolution conversion (Smoothing)
- LBP video interface

The LBP video interface transfers print signals to or from the printer controller and sends them to the MPU. The interface transmits an image signal (nVDO) and a vertical sync signal (nTOP) to the printer section, receives a horizontal sync signal (nBD) and printer section status from the printer section and transfers them to the MPU.

- OPCNT serial interface
- DRAM/SRAM controller
- Document feed motor control
- Reduction in vertical scanning
- Recording decoder
- Pickup solenoid control
- RTC (Real Time Clock) control

The RTC is backed up by lithium battery, and counts the data and time.

- SRAM

SRAM is backed up by lithium battery. SRAM holds data registered for system control and communications management information.

a-3) Main ROM (SOC1)

This 16 Mbit ROM contains the control programs (e.g. operation panel, scanner and communications section etc.) for this fax.

a-4) DRAM (IC9)

This 64 Mbit is used as memory for storing image data, and as an MPU work area.

b) Communication control section

Modem IC (IC36)

A Conexant R288F-26 (PLCC type) is used as the MODEM IC. The MODEM IC carries out G3 modulation conforming to ITU-T standards V.34, V.29, V.27ter, V.21 and V.8 on transmitted data received from the MPU during transmission. During reception, the MODEM IC carries out G3 modulation on received signals from the telephone line, according to the same standards.

c) Document scanning section

c-1) System controller (IC10)

The system controller IC include image processing function (UHQ) are as follows:

- Serial-to-parallel conversion
- A/D conversion
Input signals from the contact sensor are A/D converted.
- ABC(Auto Background Control)
Sets the slice level for each scan line.
- Edge enhancement processing
- Binaryzation processing
- Halftone processing

d) Printer control section (SCNT board)

The printer control section is made up of the printer controller IC (IC 501). The printer controller IC is a microcomputer that incorporates a Fujitsu MBCU34102-105 8kbyte ROM and a 256byte RAM. The ROM contains printer control software to control LBP operations.

The printer control section receives commands from the system controller IC and controls paper pickup and loading, and the LASER/scanner unit.

The printer control section transfers the signal received from the printer section to the system controller IC as printer status.

The printer controller IC has the following other functions:

- Main motor control
- Fixing heater control
- Fixing heater temperature detection
- BD signal detection
- LASER drive control
- APC control
- Scanner motor, fixing ass'y, or BD failure detection
- Control of high-voltage power supply

e) Fixing/high-voltage controller (IC301)

Fixing heater control

The overvoltage prevention function is available to control power supply to the fixing roller heater using a heater drive signal (FSRD) from the SCNT board, detect resistance value of the thermistor in the fixing roller heater, prevent fixing roller heater temperature rise using a thermal fuse, protect the print PC board against overvoltage.

High-voltage power supply

The high-voltage power supply provides the high voltage required for primary charging, development, and transfer using a control signal from the SCNT board.

5.3 Flow of Image Signals

a) G3 transmission

- (1) With the LED as a light source, the image is scanned by the contact sensor, and analogue image data sent to the SCNT board.
- (2) The System controller IC (Internal UHQ unit) converts analogue image data from the contact sensor to digital image data.
- (3) The system controller IC converts processed image data from serial data to parallel data, and writes them to the DRAM.
- (4) The MPU encodes raw data in the DRAM using a soft codec, and rewrites the encoded data into the DRAM.
- (5) The MODEM IC modulates the coded image data.
- (6) The modulated data are then sent from the MODEM IC to the NCU board.

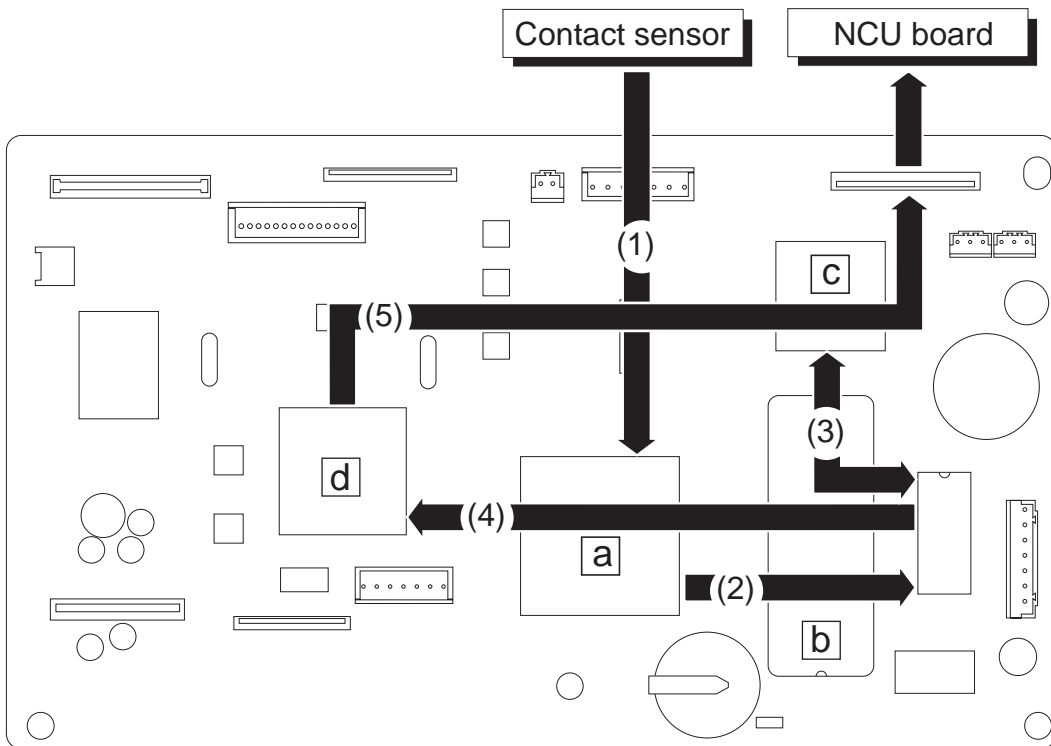

- a System controller IC
- b DRAM
- c MPU
- d MODEM IC

Figure 2-8 G3 Transmission Image Signal Flow

b) G3 Reception

- (1) Image signals received by L1, L2, pass through the hybrid circuit in the NCU, and are amplified. The modem demodulates these image, and writes them to the DRAM.
- (2) The MPU decodes the demodulated image data, checks errors, stores it in the DRAM, encodes the data and rewrites it into the DRAM.
- (3) After one page is received, the encoded data in DRAM is decoded by the system controller IC.
- (4) The system controller IC then converts the resolution of the fax data to the appropriate resolution for the printer data, and send it to the printer controller IC on the SCNT board.
- (5) The printer controller IC prints data by controlling the main motor, LASER, and high voltage according to the received print data.

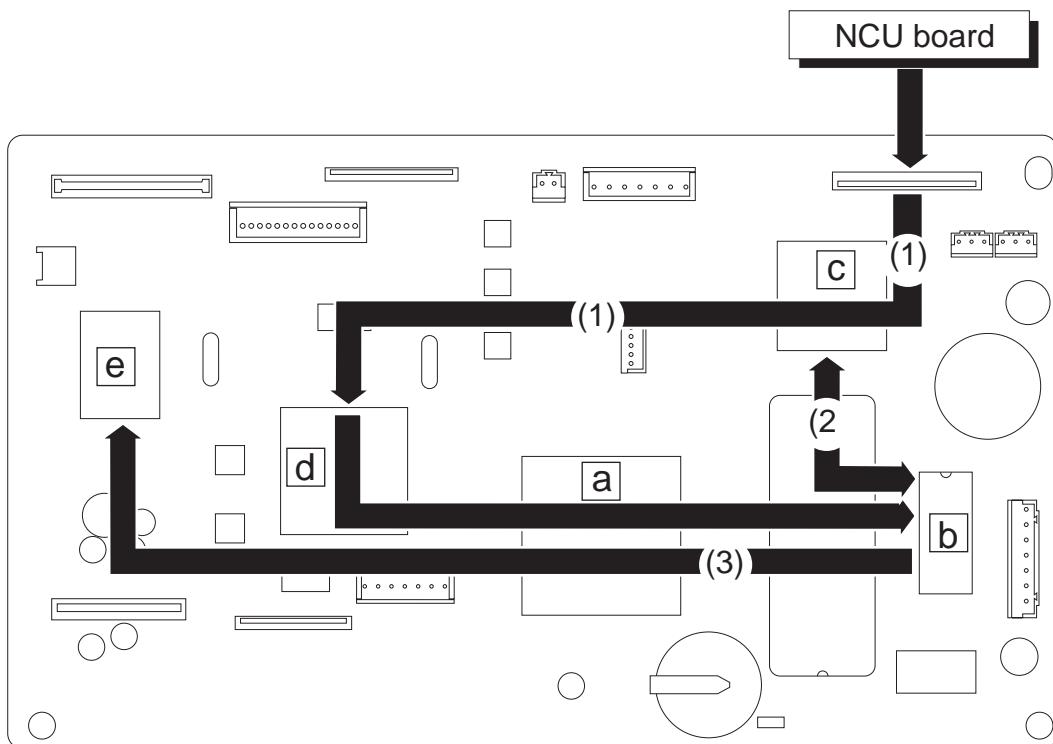

- a** System controller IC
- b** DRAM
- c** MPU
- d** MODEM IC
- e** Printer controller IC

Figure 2-9 G3 Reception Image Signal Flow

6. COMMUNICATION SYSTEM OPERATIONS

6.1 FAX/TEL Switching

This fax is set to automatically switch between fax and telephone, on the same telephone line. If the other party is a fax, the fax is received automatically, and if the other party is a telephone, the alarm in the main unit is rung to alert the user. This fax sends a pseudo-RBT to the sender during FAX/TEL switching. It sounds a pseudo-bell when the other party is a telephone.

6.1.1 Settings

- (1) Press the *Receive MODE* button to select Fax/Tel mode.
- (2) Set the parameters in “**Receive Mode**” menu.

6.1.2 Parameters

Item	Default setting	Setting switch	Selection range
RING START TIME (Pseudo Ring start time)	8 sec	User data	0 to 30 sec
F/T RING TIME (Pseudo Ring time)	22 sec	User data	10 to 60 sec
F/T SWITCH ACTION (Operation after FAX/TEL switching)	RECEIVE	User data	RECEIVE/ DISCONNECT
Pseudo RBT frequency	400 Hz	None	None(fixed)
Pseudo RBT transmission from CML on time until start (CNG detection time)	4 sec	Service data #3 16	0 to 9 sec
Pseudo RBT pattern on time	1000 ms	Service data #3 17	0 to 9990 ms
Pseudo RBT pattern off time (short)	0 ms	Service data #3 18	0 to 9990 ms
Pseudo RBT pattern off time (long)	4000 ms	Service data #3 19	0 to 9990 ms
Pseudo RBT transmission level	-10 dBm	Service data #3 24	-15 to 0 dBm
Pseudo ring frequency	25 Hz	Service data #2 10	17 Hz/25 Hz/50 Hz
Pseudo ring pattern on time	1000 ms	Service data #3 20	0 to 9990 ms
Pseudo ring pattern off time (short)	0 ms	Service data #3 21	0 to 9990 ms
Pseudo ring pattern off time (long)	4000 ms	Service data #3 22	0 to 9990 ms

6.2 Answering Machine Connection

This connection is for effective use of an answering machine connected to the extension telephone jack. If the other party is a telephone, the answering telephone records the message, and if the other party is a fax, the fax receives automatically.

6.2.1 Settings

- (1) Connect the answering machine to the extension telephone jack, and set the answering machine to **“ANSWER”**.
- (2) Press the fax’s *Receive MODE* button and select the **ANS.MACHINE MODE**.

6.2.2 Parameters

Item	Default setting	Setting switch	Selection range
Signal detection time	60 sec	Service data #3 25	0 to 999 sec

6.3 Manual/Auto Reception Switching

Determines if the fax switches to document receive mode after the fax rings for a specified time when the fax is in the manual receive mode.

6.3.1 Settings

- (1) Set the **“MAN/AUTO SWITCH”** in the user data **“RX MODE”** to **“ON”**.
- (2) Set the number of seconds that the fax will wait after detecting ringing signal from the telephone line before going into reception, using user data **“F/T RING TIME”** in **“MAN/AUTO SWITCH”**.

6.3.2 Parameters

Item	Default setting	Setting switch	Selection range
MAN/AUTO SWITCH	OFF	User data	ON/OFF
F/T RING TIME	15 sec	User data	1 to 99 sec

7. NEW FUNCTION

7.1 High-speed Transmission

The image transmission time is reduced drastically compared with the previous models by the V.34 modem (maximum transmission speed 33600 bps) recommended by ITU-T.

7.1.1 V.8/V.34 protocol

a) Outline

- The V.8 protocol is used as the startup protocol to move to V.34. The V.8 protocol enables connection with fax machines, data modem and equipment using existing V-series modems. The V.34 modem contains a modem circuit based on the previous recommendation to connect with the previous modems and has upper compatibility.
- The actual data transmission speed is improved entirely on average by speeding the modulation method and utilizing new techniques, such as the pre-emphasis technique*¹ for increasing the S/N (signal-to-noise) ratio and the probing technique*² for measuring line characteristics and optimizing the modem operation according to the line condition.
- The V.8 protocol, V.34 pre-protocol and post-protocol use full-duplex transmission to speed the processing.
- Fourteen image transmission speeds*³ are available:
33600, 31200, 28800, 26400, 24000, 21600, 19200, 16800, 14400, 12000, 9600, 7200, 4800, and 2400 bps
- The modulation speed (baud rate)*⁴ can be selected from among 2400, 3000, and 3200 symbols/sec (required) or 2743, 2800, and 3429 symbols/sec (option). The data transmission speed can be set more finely than the previous modems.



NOTE

*1 The output level of a high-frequency zone with comparatively high noise is raised, and then the transmission signal is sent.

*2 A tone signal known as a probing signal (L1 and L2) is output, and the receiving side measures the characteristics of the line.

*3 The data signaling rate is recorded in the ITU-T standards manual. Image transmission speed means the same as data signaling rate.

*4 The symbol rate is recorded in the ITU-T standards manual. Symbol rate means the same as moderation speed and baud rate.

2743 symbol/sec cannot be used with this fax.



NOTE

-
1. The V.34 protocol uses ECM. If the ECM SW in user data is set to OFF, the V.8 protocol is not executed. Therefore, the V.34 protocol is not used, and V.17 or a lower protocol is selected.
 2. If the transmission speed is set to 14400 bps or lower, the V.8 protocol is not executed and V.17 or a lower protocol is selected.
 3. After the V.21 protocol is selected first, it can be changed to V.8 or V.34. (See c-1)
 4. When the V.34 protocol begins, it falls back within the V.34 protocol, but it does not fall back to the V.17 mode or lower.
-

b) Typical protocol

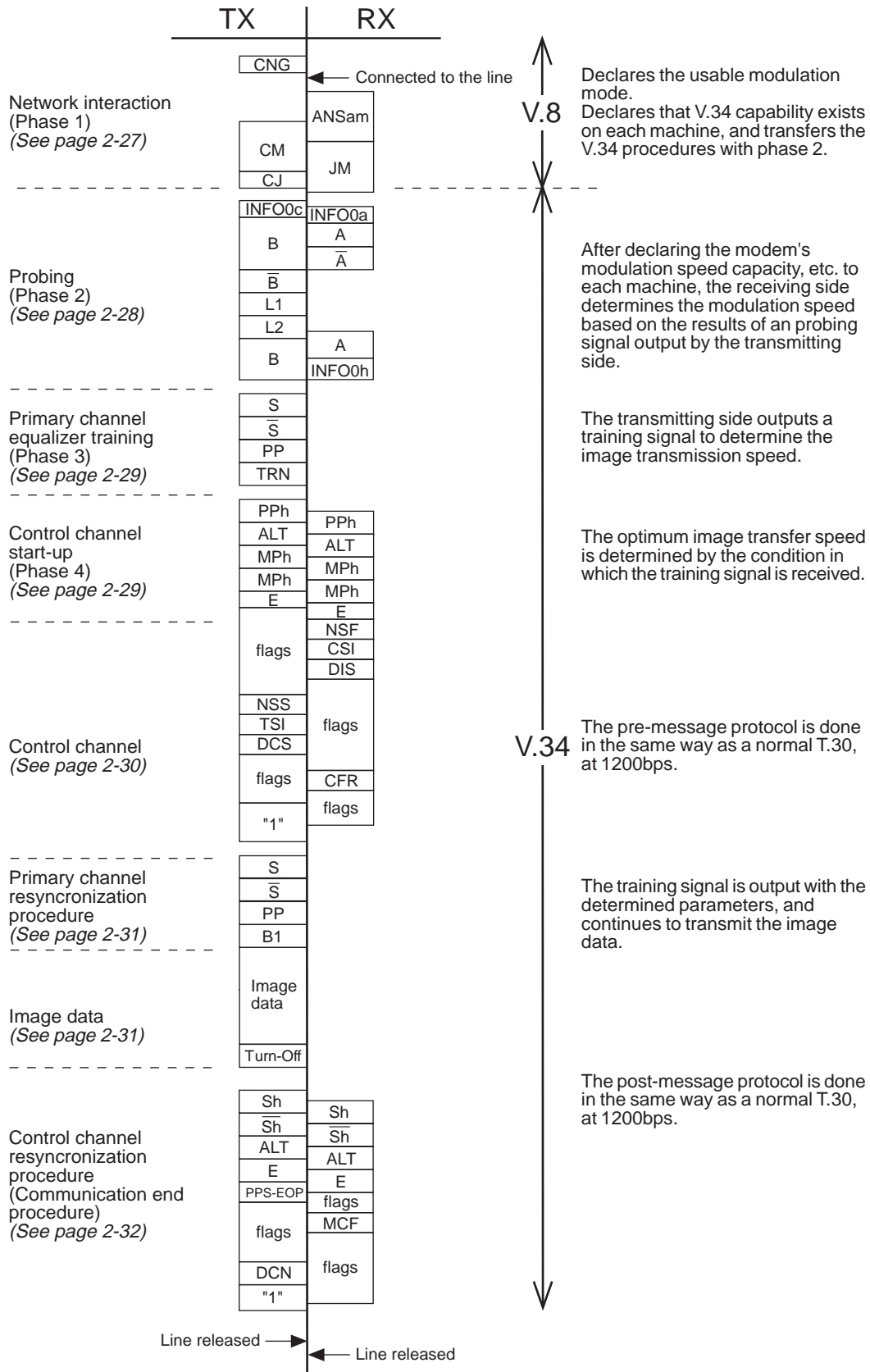

Figure 2-10 Typical Protocol

b-1) Network interaction (Phase 1)

The V.8 protocol is used as the startup protocol for high-speed modem V.34.

The V.8 protocol determines the best modulation method (V-series modem mode) that is available between the transmitter and receiver.

• Transmitter

Signal	Abbreviation	Meaning	Remarks
Calling tone	CNG	1100-Hz tone signal specified by T.30 to identify an automatic-calling fax machine.	
Dial-tone menu signal	CM	Indicate an available modulation method (V.21, V.27ter, V.29, V.17, or V.34).	Modulated by V.21(L)* ¹ .
CM terminator	CJ	Indicate JM signal detection and CM signal termination.	Modulated by V.21(L)* ¹ .
Dial-Tone display signal	CI	Indicate the general transmission function. Sent to resume the V.8 protocol.	Late start only. (See <i>Figure 2-11</i> .) Modulated by V.21(L)* ¹ .

• Receiver

Signal	Abbreviation	Meaning	Remarks
Modified response tone	ANSam	2100-Hz tone signal amplitude-modulated by 15 Hz.	Equivalent to CED for previous models.
Common menu	JM	Indicate the terminal type, such as a fax machine, and an available modulation method in response to the available modulation method reported by the CM from the transmitter.	Modulated by V.21(H)* ¹ .

*¹ V.21(L): Low-frequency channel defined by V.21 recommendation
1080±100 Hz (980 Hz:1, 1180 Hz:0)
Transmission speed: 300bps

V.21(H): High-frequency channel defined by V.21 recommendation
1750±100 Hz (1650 Hz:1, 1850 Hz:0)
Transmission speed: 300bps

b-2) Probing (Phase 2)

The line characteristics are measured and modulation-related parameters, such as symbol rate, are set.

• Transmitter

Signal	Abbreviation	Meaning	Remarks
INFO sequence	INFO0c	Indicate modem capabilities, such as baud rate and frequency transmission function (two frequency bands used to measure line characteristics), and request adjustment.	Transmission speed: 600bps
Tone B	B	Modem synchronization with a 1200-Hz tone signal.	The phase of the B-signal is inverted 180 degrees from the phase of the B signal.
Tone \bar{B}	\bar{B}		
Probing signal L1	L1	Tone signal for analyzing line characteristics by probing.	Probing: Measurement of line characteristics. Tone signal in the range 150 to 3750 Hz in 150-Hz steps.
Probing signal L2	L2		

• Receiver

Signal	Abbreviation	Meaning	Remarks
INFO sequence	INFO0a	Report the modem capabilities, such as baud rate and frequency transmission ability.	Transmission speed: 600bps
Tone A	A	Modem synchronization with a 2400-Hz tone signal.	The phase of the A-signal is inverted 180 degrees from the phase of the A signal.
Tone \bar{A}	\bar{A}		
INFO sequence	INFO0H	Report the pre-emphasis filter and baud rate used for data transmission based on the result of analysis of the probing signal.	Transmission speed: 600bps

b-3) Primary channel equalizer training (Phase 3)

Filters, such as equalizers, are trained (adjusted) with the parameters set in phase 2.

• **Transmitter**

Signal	Abbreviation	Meaning	Remarks
S signal	S	Short training	The phase of \bar{S} is shifted from the phase of S.
\bar{S} signal	\bar{S}		
PP signal	PP	The other modem uses this signal to train the equalizer.	
TRN signal	TRN	The receiver uses this signal to determine the transmission speed.	

b-4) Control channel start-up (Phase 4)

Select the maximum data signalling rate and trellis encoder and set the data signalling rate that can be supported.

• **Transmitter/receiver**

Signal	Abbreviation	Meaning	Remarks
PPh signal	PPh	The other modem uses this signal to train the equalizer.	
ALT signal	ALT	_____	
Modulation parameter	MPh	Indicate the image transmission parameters, such as maximum data signal speed, control channel data signal speed, trellis coding type, precoding type, and baud rate.	
E sequence	E	_____	20-bit sequence of binary 1's

b-5) Control channel

The conventional T.30 protocol is executed.
The transmission speed is 600bps.

• Transmitter

Signal	Abbreviation	Meaning	Remarks
Flag	flags	Maintain synchronization	7E (H)
Non-standard facilities set-up	NSS	Receive NSF from the other party, select an available mode from it, and instruct reception.	
Transmitting subscriber identification	TSI	Report the transmitter telephone number.	
Digital command signal	DCS	Instruct the available mode.	
	1	Declare to switch to high-speed protocol	Transmit 1'S

• Receiver

Signal	Abbreviation	Meaning	Remarks
Non-standard facilities	NSF	Report functions not recommended by ITU-T, user's ID, manufacturer code, etc.	
Called subscriber identification	CSI	Report the receiver telephone number.	
Modulation parameter	DIS	Report standard ITU-T-recommended functions.	
Flag	flags	Maintain synchronization.	7E (H)
Confirmation to receive	CFR	Report that modem training ends and image signal reception is ready.	



NOTE

In the control channel, signals which differ according to the frequencies of both TX and RX are output. It follows that the effects of the echo are not received because the frequencies of the signal returned by echo and the signal output by the other machine are different.

b-6) Primary channel resynchronization procedure

Training is performed with the parameters set in phase 4.

The transmission speed is 1200bps.

• **Transmitter**

Signal	Abbreviation	Meaning	Remarks
S signal	S	Short training	The phase of \bar{S} is shifted from the phase of S.
\bar{S} signal	\bar{S}		
PP signal	PP	The other modem uses this signal to train the equalizer.	
Sequence B1	B1	Scramble data frame transmitted at the end of start-up protocol.	

b-7) Image data

Transmit image data.

• **Transmitter**

Signal	Abbreviation	Meaning	Remarks
Image data	Image data	Encoded image data	
_____	Turn-off	_____	Send scrambled 1's for 35 ms.

b-8) Control channel resynchronization procedure (Communication end procedure)

Protocol for terminating transmission.

The transmission speed is 1200bps.

• Transmitter

Signal	Abbreviation	Meaning	Remarks
Sh signal	Sh	Short training	
Sh signal	Sh		
ALT signal	ALT	_____	
E sequence	E	_____	
End of procedures	PPS-EOP	One page is transmitted.	
Flag	flags	Maintain synchronization.	7E (H)
Disconnect signal	DCN	Disconnect the line.	

• Receiver

Signal	Abbreviation	Meaning	Remarks
Sh signal	Sh	Short training	
Sh signal	Sh		
ALT signal	ALT	_____	
E sequence	E	_____	
Flag	flags	Maintain synchronization.	7E (H)
Message confirmation	MCF	Indicate that the receiver has received the image signal correctly and can receive the next document immediately.	

c) Examples of sequences

The signals in the shaded areas are important in the protocol.

c-1) Late start

Since the receiver cannot detect the CM signal while sending the ANSam signal, it sends the DIS signal containing the "V.8 protocol" declaration. The transmitter sends the CI signal to request the receiver to send the ANSam signal again to move to V.8 protocol.

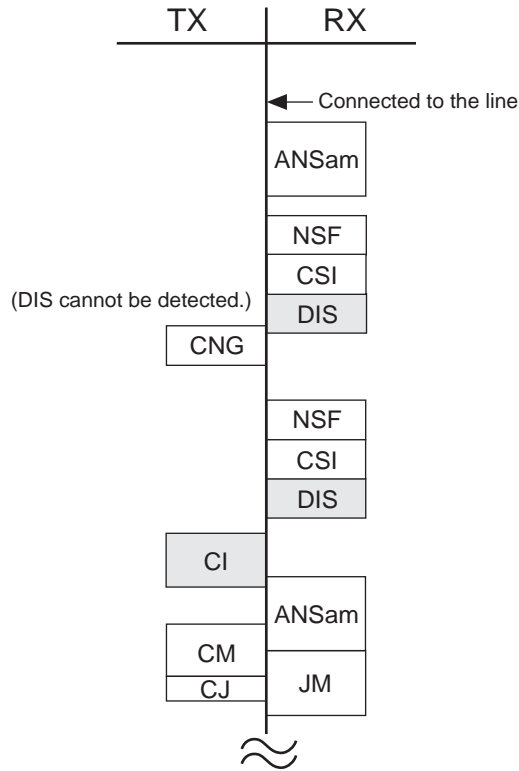

Figure 2-11 Late Start

c-2) Between-page sequence

The transmitter sends image data, then the PPS-MPS signal in the same as for the T.30 protocol. The receiver sends the MCF signal to receive the next page.

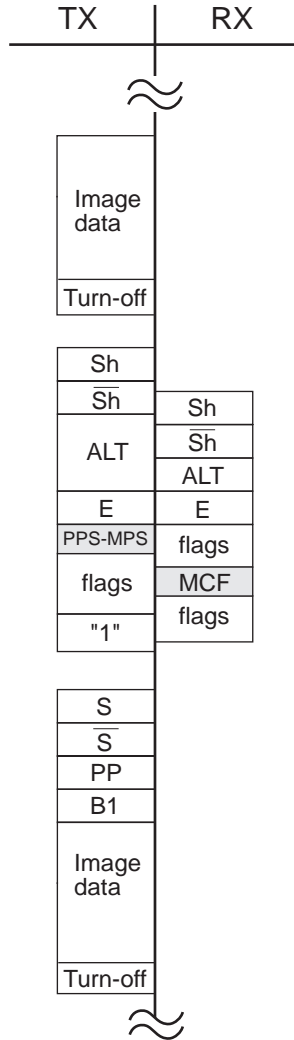

Figure 2-12 Between-page Sequence

c-3) Mode change

The transmitter sends PPS-EOM and the receiver sends the MCF signal. Then the receiver sends the DIS signal and the transmitter sends the DCS signal to change the mode.

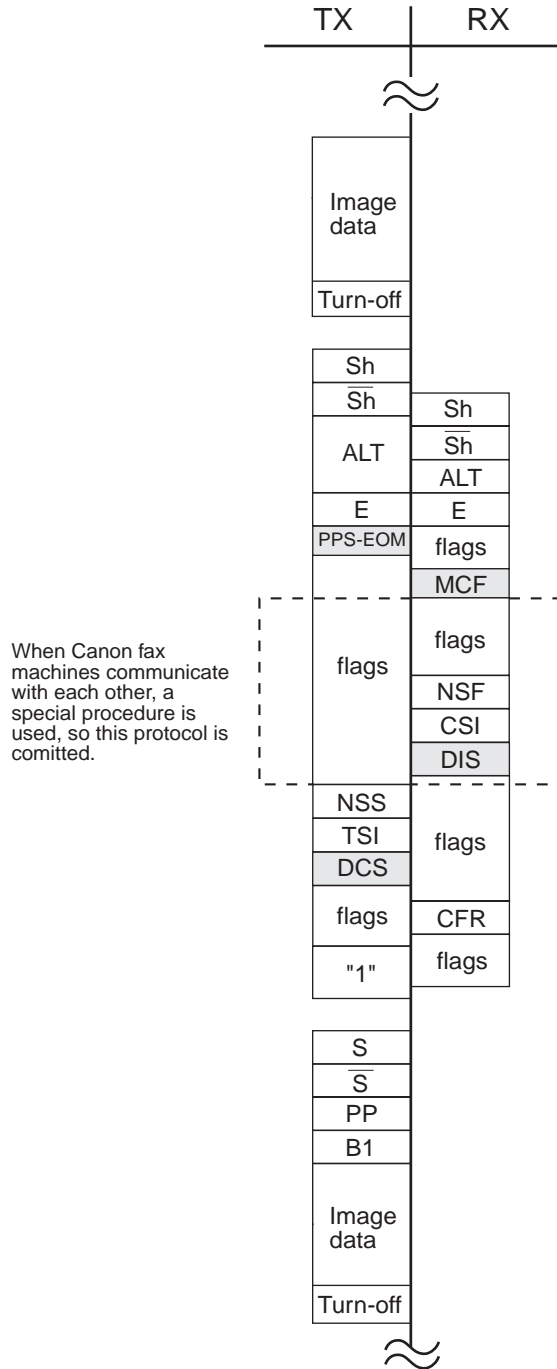

Figure 2-13 Mode Change

c-4) Image transmission speed change from the receiver

The receiver returns to the PPh signal in response to the Sh signal from the transmitter. The image transmission speed is then determined by the MPh sequence sent from both modems.

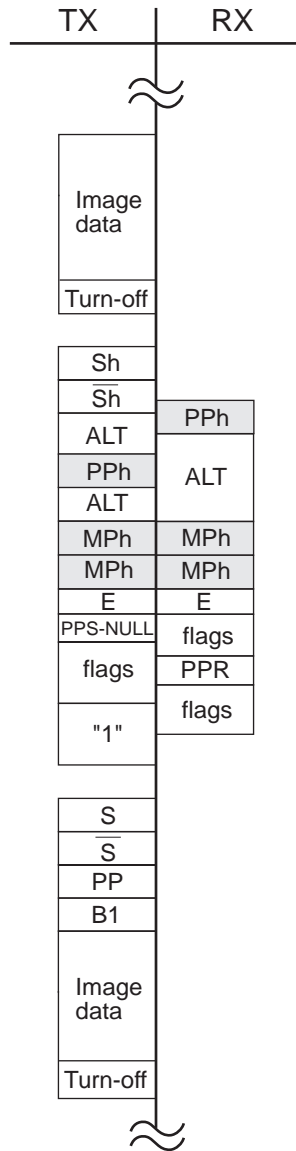

Figure 2-14 Image Transmission Speed Change from the Receiver

c-5) Image transmission speed change from the transmitter

The transmitter sends image data, and then the PPh signal, and the receiver returns the PPh signal to the transmitter. The image transmission speed is then determined by the MPh sequence sent from both modems.

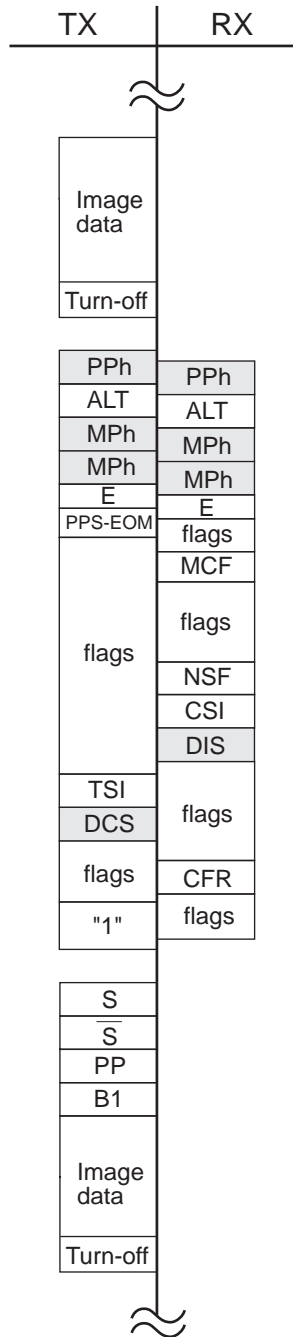

Figure 2-15 Image Transmission Speed Change from the Transmitter

7.2 JBIG Image Compression Encoding Method

7.2.1 Outline of the JBIG image compression encoding method

The JBIG Image Compression Encoding Method is recommended in ITU-T T.82/T.85 as a new bi-level (bi-level: White and Black) image compression encoding method developed by JBIG (Joint Bi-level Image experts Group).

The JBIG Image Compression Encoding Method has the following characteristics with regards to text documents, quasi-gray scale images with little continuous black and white, and gray scale images which use a dithering method: a higher compression rate (1.1 ~ 30 times higher) than the conventional MMR compression method, the encoded volume will not exceed the volume of original image information after compression, and when decoding, the image can be completely re-assembled to its original condition in the same way as with conventional MR/MMR.

The JBIG Image Compression Encoding Method contains Progressive Bi-level Image Compression for searching image databases, recommended in ITU-T T.82, and Single Progression Sequential Bi-level Image Compression for facsimile, recommended in ITU-T T.82 and T.85.

Images will take on the form shown below.

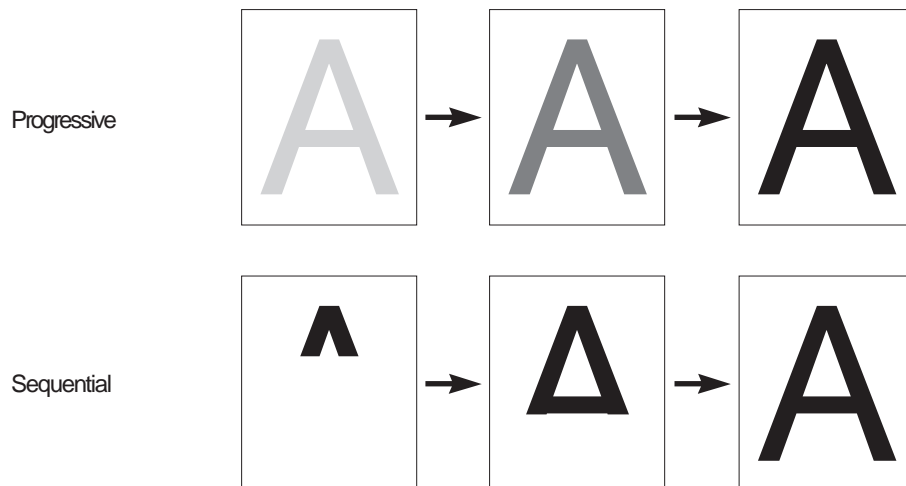

Figure 2-16 Images



NOTE

The characteristics of Progressive Bi-level Image Compression are explained below as a reference. First of all, after the original image has been read in at high resolution, it is converted to low resolution, and this low resolution image data proceeds to be encoded (compressed). On the receiving end, the overall original image can be quickly recognized by the steps in which this low resolution image compression data is received.

Next, to improve the quality of the low resolution image already sent, only information needed to improve the resolution is forwarded. The previous low resolution image is decoded on the receiving side with this information, and following this, the high resolution image is displayed on top of the previous low resolution image.

It is easy to quickly recognize the original image in the process of displaying the image from low resolution to high resolution in order by using this method, with a CRT display for example. Also, according to the situation, it is possible to interrupt the image transfer at the point where the original image is recognized to some degree by the receiving side.

This method requires a page buffer memory for the low resolution image because the low resolution images are used for the purpose of high resolution image encoding.

7.2.2 Single progression sequential bi-level image compression method

The Single Progression Sequential Bi-level Image Compression Method used in this fax is explained below. The Progressive Bi-level Image Compression Method uses multiple resolution layers on a single page (multi-level layers, low resolution layers~high resolution layers) to perform encoding/decoding. In the Single Progression Sequential Bi-level Image Compression Method, encoding is done in units of horizontal bands (a number of lines) called stripes, and is performed from left to right, top to bottom (this condition is called sequential), and in one resolution layer (single layer).



NOTE

In this method, the encoding is done in stripe units, so it is completed with a buffer memory much smaller than a page buffer memory.

The methods by which encoding takes place and by which image data is constructed after encoding are explained below.

7.2.3 Encoding method

In the JBIG encoding used in the Single Progression Sequential Bi-level Image Compression Method, uses in the encoder shown below to encode to the original results of comparison of the line currently being processed and the previous line, as well as the predicted value of an image pixel (white or black) used in a model template.

The study table used in the prediction makes the next prediction more accurate by learning and correcting the study table every time the model template moves to the adjoining pixel. It is characteristic of this method that if the prediction is accurate the amount of encoding will not increase, and if the prediction is off the amount of encoding increases, so the increase in prediction accuracy of this study table is very important. An outline of the encoding procedure is shown below.

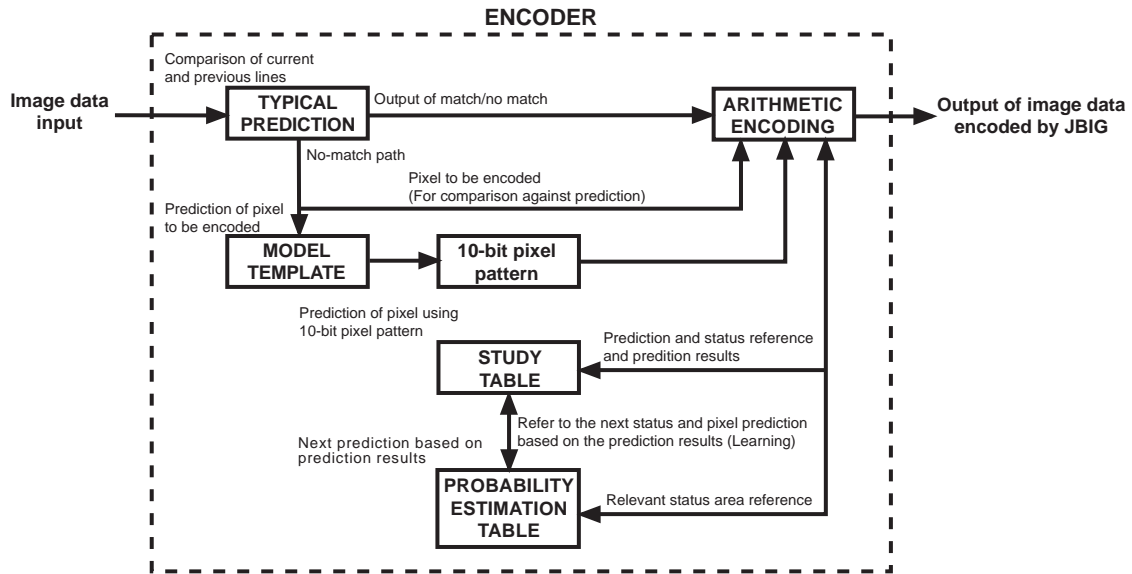

Figure 2-17 Encoder and Flow of JBIG Encoding

- a) In the pattern prediction section, the line currently being processed and the current line are compared, and judged to match or not match. A flag showing whether or not the lines match (1 bit, 0: match, 1: don't match) is attached to the head of each line according to this judgment. When the lines match, only this flag is encoded in the arithmetic encoding section as a suspected pixel, the pixel of the line being currently processed is not encoded. When the lines do not match, the pixel of the line currently being processed is encoded in the arithmetic encoding section based on the results of a comparison of the value of the actual pixel and the pixel (white or black) which is predicted using the model template and the study table.



NOTE

When the lines are judged to match, the line currently being processed is said to be **“typical”** . When the lines are judged to not match, the line is said to be **“not typical”** . When the very first line of an image is predicted, the background color is used as the previous line.

b) In the model template, the combination (10-bit pixel pattern) of 10 pixels is output to the arithmetic encoding section using the template shown below (inside the bold outline).

All of the 10-bit pixel patterns inside this template exist in the study table. This 10-bit pixel pattern is used by the arithmetic encoding section to refer to the predicted value of the pixel and the status number in the study table which correspond to the 10-bit pixel pattern.

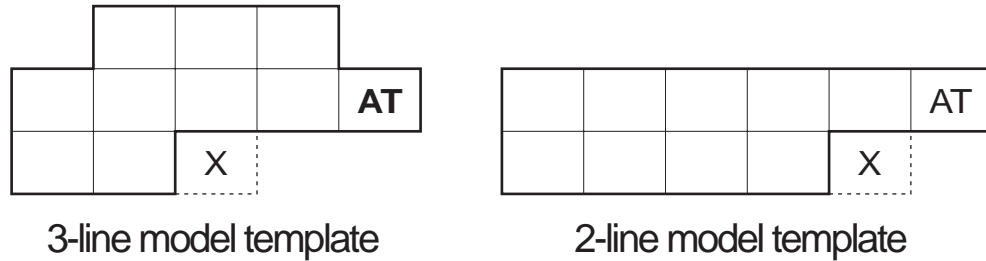

Figure 2-18 Model Templates



NOTE

There are two types of model templates 3-line and 2-line, and the one selected is designated by the LRLTWO inside the Bi-level Image Header section (BIH). The pixel shown by “X” is an encoded pixel and is outside of the template.

The pixel shown by “AT” is a special pixel known as an AT pixel. The AT pixel becomes a Adaptive Template by having its position moved, and is very effective when encoding a periodic pixel, similar to a dither pattern image.

The position of AT in the figure is the beginning position of the AT pixel.

In this fax, it remains fixed in this initial position, so Adaptive Template is not used.

c) The study table, as shown below, is constructed by all of the 10-bit pixel patterns output by the model template, and their corresponding status numbers and predicted values of the pixel to be encoded.

The predicted value of the pixel to be encoded and the status number is compared to the actual pixel in the arithmetic encoding section every time the model template is moved to the adjoining pixel.

The result of this comparison (matches / does not match predicted value) and the status number are then checked by comparison to the probability estimation table, and the study table is corrected (learned) to a new prediction value and status number which will be used when the same pixel pattern is found again. By learning in this way, the probability of the study table matching the next time is increased, and the need for encoding decreased.

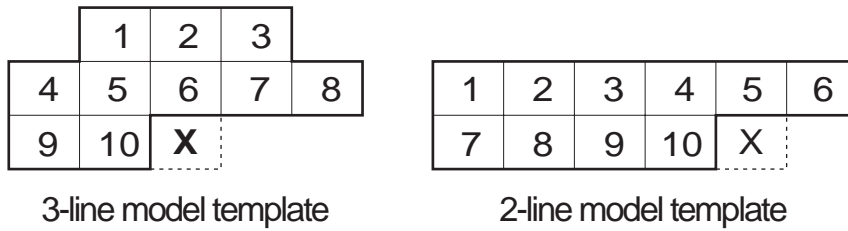

Figure 2-19 Positions of Pixels in Model Template

Table 2-1 Study Table (Initial values)

Pixel pattern in the model template											Predicted value of pixel	Status No. (ST)	
Hex	Dec	1	2	3	4	5	6	7	8	9			10
000h	0	0	0	0	0	0	0	0	0	0	0	0 (white)	0
001h	1	0	0	0	0	0	0	0	0	0	1	0 (white)	0
002h	2	0	0	0	0	0	0	0	0	1	0	0 (white)	0
003h	3	0	0	0	0	0	0	0	0	1	1	0 (white)	0
004h	4	0	0	0	0	0	0	0	1	0	0	0 (white)	0
005h	5	0	0	0	0	0	0	0	1	0	1	0 (white)	0
~ ~ ~ ~ ~													
3FBh	1019	1	1	1	1	1	1	1	0	1	1	0 (white)	0
3FCh	1020	1	1	1	1	1	1	1	1	0	0	0 (white)	0
3FDh	1021	1	1	1	1	1	1	1	1	0	1	0 (white)	0
3FEh	1022	1	1	1	1	1	1	1	1	1	0	0 (white)	0
3FFh	1023	1	1	1	1	1	1	1	1	1	1	0 (white)	0

Table 2-2 Probability Estimation Table

ST	LSZ	NLPS	NMPS	SWITCH	ST	LSZ	NLPS	NMPS	SWITCH
0	5A1Dh	1	1	1	57	01A4h	55	58	0
1	2586h	14	2	0	58	0160h	56	59	0
2	1114h	16	3	0	59	0125h	57	60	0
3	080Bh	18	4	0	60	00F6h	58	61	0
4	03D8h	20	5	0	61	00CBh	59	62	0
5	01DAh	23	6	0	62	00ABh	61	63	0
6	00E5h	25	7	0	63	008Fh	61	32	0
7	006Fh	28	8	0	64	5B12h	65	65	1
8	0036h	30	9	0	65	4D04h	80	66	0
~ ~ ~ ~ ~									
49	0706h	79	50	0	106	50E7h	108	107	0
50	05CDh	48	51	0	107	4B85h	109	103	0
51	04DEh	50	52	0	108	5597h	110	109	0
52	040Fh	50	53	0	109	504Fh	111	107	0
53	0363h	51	54	0	110	5A10h	110	111	1
54	02D4h	52	55	0	111	5522h	112	109	0
55	025Ch	53	56	0	112	59EBh	112	111	1
56	01F8h	54	57	0					

- ST: Status number in the study table
- LSZ: Probability estimation value (range) for inaccurate prediction
- NLPS: Next status destination when a prediction is inaccurate
- NMPS: Next status destination when a prediction is accurate
- SWITCH: Next prediction value reversed if SWITCH=1 when prediction is inaccurate

Example:

A brief explanation of how the study table works is given below.

It is assumed that each of the model template pixels 1~10 in the image below are white.

1. In this case, the model template pixel pattern is 000h.
2. The predicted value of pixel pattern 000h for pixel "X" is "white", but it is actually black. Thus the prediction is "inaccurate".
3. The status ST is "0", so the probability estimation table is consulted, and the next status is moved to "1". At the same time, by the reversal of the predicted value, the next prediction is for "black".

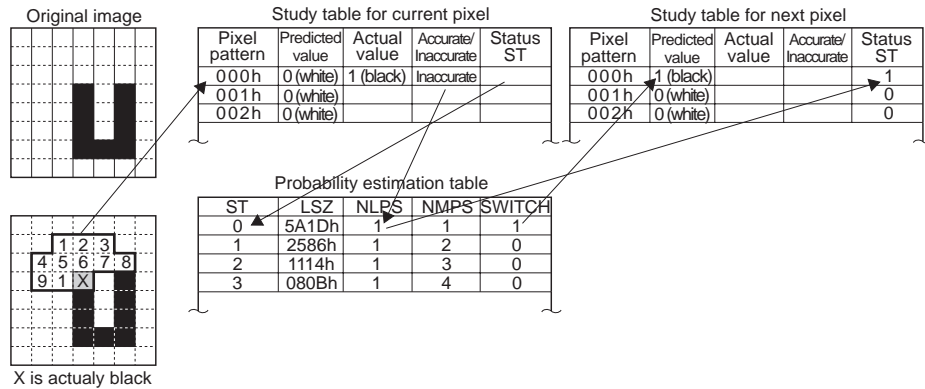

Figure 2-20 Study Table Study Example 1

4. Next, the model template is moved to the adjoining pixel in order to perform the next prediction. At this time, pixels 1~9 of the model template are white, and pixel 10 is black.
5. In this case, the model template pixel pattern is 001h.
6. The predicted value of pixel pattern 001h for pixel "X" is "white", and it is actually white. Thus the prediction is "accurate".
7. The status ST is "0", so the probability estimation table is consulted, and the next status is moved to "1". The prediction for the next pixel remains "white".

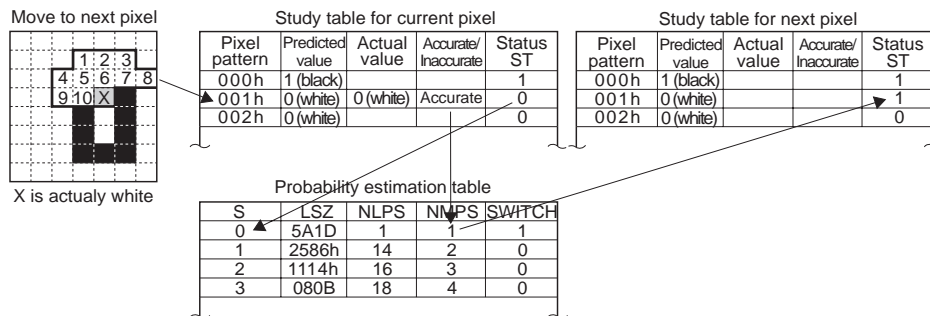

Figure 2-21 Study Table Study Example 2

The study table is constantly updated in this way, increasing the probability of accurate predictions.

- d) The probability estimation table, published in the ITU-T T.82. Its contents are fixed, differing from those of the study table.



NOTE

This table shows probability of accuracy/inaccuracy in the form of a range, according to the accurate/inaccurate results of a given status prediction value.

The plan of the probability estimation table is such that if the prediction is accurate, the range of the next status number will be smaller than would be the case in an inaccurate prediction.

The status number with this smaller range will be selected to be the next status number.

- e) After the predicted value is found to be accurate/inaccurate by the actual pixel, the model template, and the study table, that accuracy/inaccuracy is encoded in the arithmetic encoding section, and the encoded image data is output.
- f) In the encoding (mathematical encoding) done in the arithmetic encoding section, there is no conversion table for encoding as is the case in encoding with conventional MH and MR. Using the LSZ (probability estimation value of an inaccurate prediction: the form of a range) of the probability estimation table and the accuracy/inaccuracy of the predicted value as a base, encoding is done by showing the position of the progress of the prediction on an integer line (between 0~1.0). Encoding shown as a position on this integer line, take a position under MPS in the case of accurate predictions, and under LPS in the case of inaccurate predictions, as shown in the figure below.

Furthermore, there is a concept of range (A) in this arithmetic encoding. This range (A)^{*2} is shown as an MPS range in the case of accurate predictions and as an LPS range in the case of inaccurate predictions for each pixel. When these ranges (A) are below a certain range^{*3}, the leading edge bit (which excludes the encoding "0". shown by the position on the integer line) shifts one position to the left as encoded image data, and is output. At this time, the limit of this range (A) which was below the certain range is narrow and it is difficult to show a position more detailed than this, so the range (A) is magnified^{*4} to show it in more detail. This operation is called "**Renormalization**", and this range (A) is reset to a value above a certain range^{*3}.

The concept of arithmetic encoding is simply explained below.

The following assumptions are made in order to make the explanation easy to understand.

The probability of accuracy will be 50%, and the probability of inaccuracy will be 50%.^{*1}

The area of accuracy will be MPS, and the area of inaccuracy will be LPS.

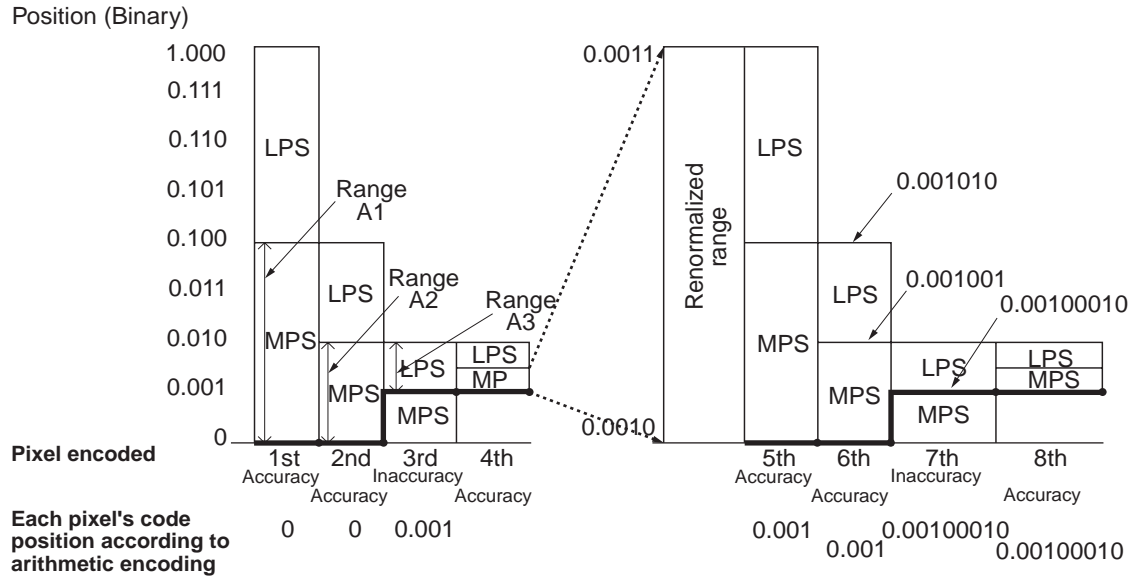

Figure 2-22 Arithmetic Encoding Conceptual Diagram

The special characteristic of this arithmetic encoding is that an additional encoding bit is not needed because the integer line position is the same as the integer line position of the previous encoding data in the case of an accurate prediction. It follows that the amount of encoding will not increase if accurate predictions continue, and the rate of compression will increase. Conversely, with inaccurate predictions, an additional encoding bit will be necessary to show the position of the inaccuracy in detail, and thus the amount of encoding will increase and the rate of compression decrease. In this way, the study table learns in order to increase the rate of accurate predictions and to reduce the amount of encoding and raise the compression rate during the encoding process, and then corrects the table parameters.



NOTE

*1 The actual probability varies with the status because of the extent to which LSZ occupies in the range (A).

*2 The actual range is hexadecimal 8000~10000.

In the case of an accurate prediction, range A1= hexadecimal 10000-LSZ, A2=A1-LSZ, and A3=A2-LSZ.

In the case of an inaccurate prediction, range A=LSZ.

*3 Actually, hexadecimal 8000.

*4 Actually, the hexadecimal value will be shifted to the left two times, and the hexadecimal will be over 8000.

Next, the encoding for continuous accurate predictions will be simply explained. The assumptions below will be made for easy understanding.

The value of an accurate LSZ will be decimal 100^{*1} in all statuses.

Range A will have limits of decimal 8000~10000^{*2}, and when range A is below decimal 8000^{*3}, the lead encoding bit will be pushed out, and the encoded image data will be output.

At this time, Range A will be adjusted so that it is over decimal 8000^{*3} (decimal 1000^{*4} added).

An accurate range will be MPS, and an inaccurate range will be LPS.

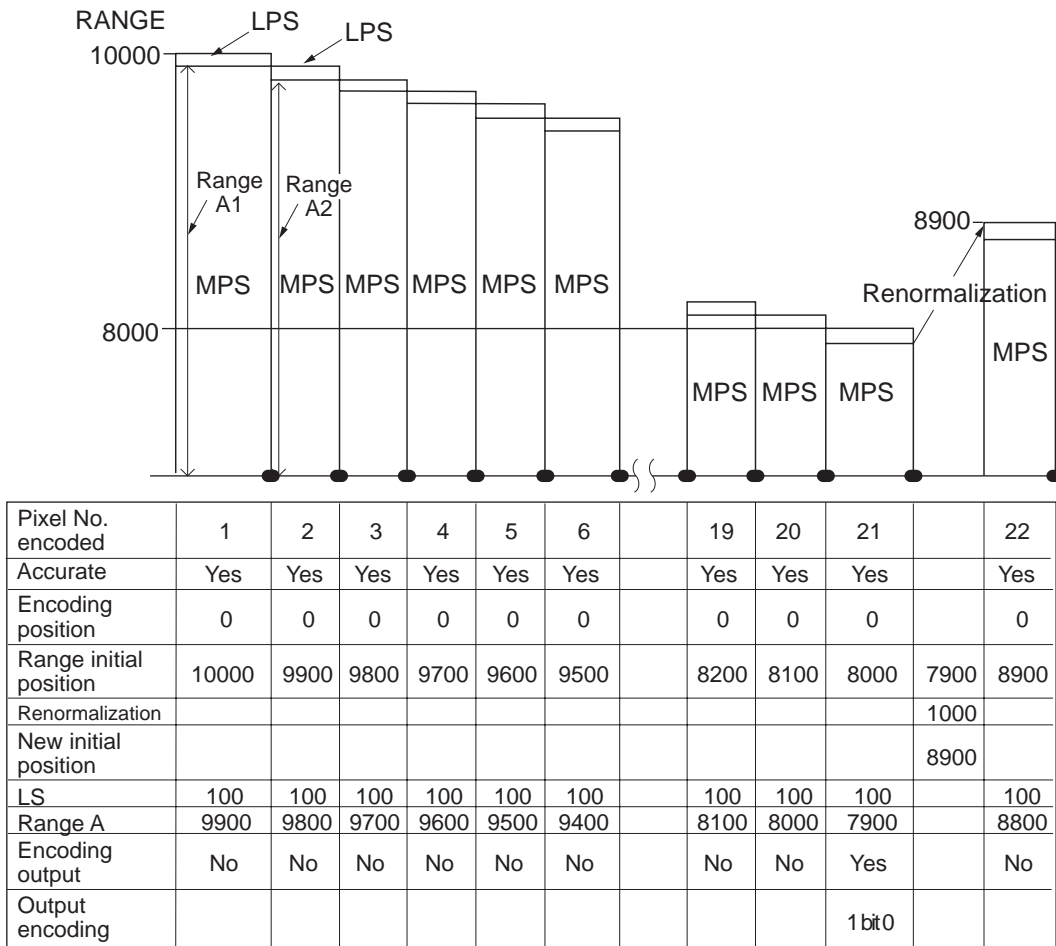

Figure 2-23 When Predictions are Continually Accurate

In this case, the encoding 1 bit is output for the first time when Range A falls becomes less than 8000 in the 21st pixel.

The following output encoding is shortened and its compression increased.

7.2.4 Construction of image data with JBIG image compression encoding

Images are encoded in block units called stripes, as shown in the figure below.

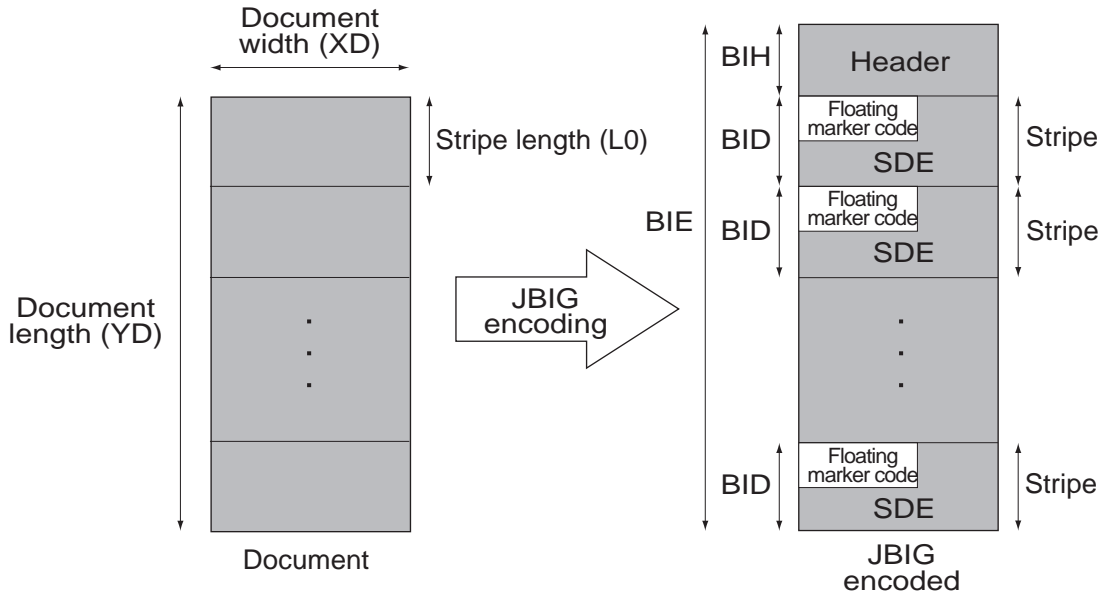

Figure 2-24 Construction of JBIG Image Data

After being encoded, the image data is referred to as BIE (Bi-level Image Entity), and is constructed from the Bi-level Image Header (BIH) section and the Bi-level Image Data (BID) section shown in the figure below.

BIE (Bi-level Image Entity)			
BIH (Bi-level Image Header)	BID (Bi-level Image Data)	BID (Bi-level Image Data)

Figure 2-25 BIE Construction Diagram

7.2.5 Explanation of bi-level image header section (BIH)

The BIH is shown in the construction figure below. It designates the image size, number of lines per stripe, model template, etc.

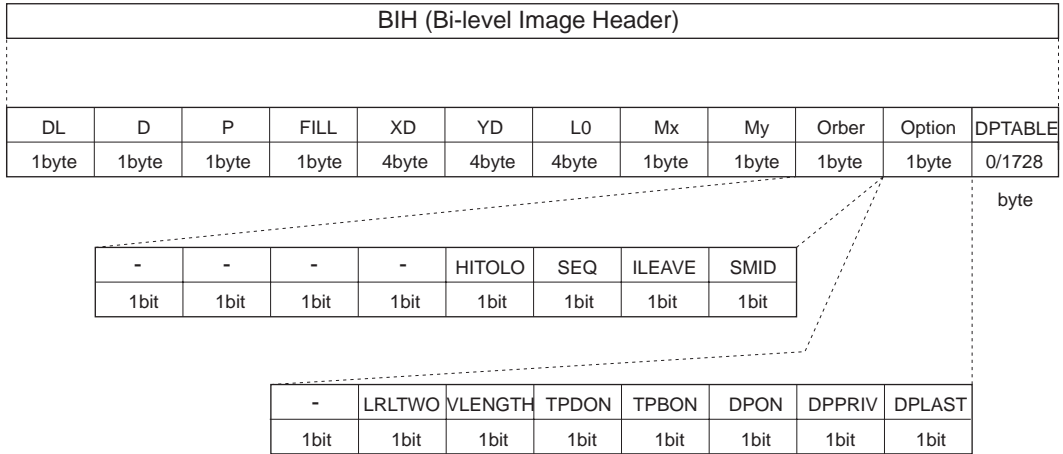

Figure 2-26 BIH Construction Diagram

7.2.6 Explanation and parameters for each symbol used in BIH

The 0x of each parameter shows that the following integers are hexadecimal.

Symbol	Meaning	Parameter	Reference
DL	Initial layer to be transmitted	0x00 fixed	
D	Number of differential layers	0x00 fixed	
P	Number of bit planes	0x00 fixed	
FILL	Fill	0x00 fixed	
XD	Horizontal image size at layer D	0XXXXXXXX	Document width (No. of bits)
YD	Vertical image size at layer D	0XXXXXXXX	Document length (No. of bits)
L0	Lines per stripe at the lowest resolution	0XXXXXXXX	Basically, 1 stripe is 128 lines (0x00000080).
other lines when machine			Stripes with numbers of are possible the other can receive in option mode.
Mx	Maximum horizontal offset allowed for AT pixel	0xXX	0-127 pixels
My	Maximum vertical offset allowed for AT pixel	0x00 fixed	
Order	The order in which stripe data is attached	Upper 4 bits 0 fixed	
Option	Option	Upper 1 bit 0 fixed	
DPTABLE	Private DP table	0 or 1728 bytes	
HITOLO	Transmission order of differential layers	1 bit 0 fixed	
SEQ	Indication of progressive-compatible sequential coding	1 bit 0 fixed	
ILEAVE	Interleaved transmission order of multiple bit plane	1 bit 0 fixed	
SMID	Transmission order of stripes	1 bit 0 fixed	
LRLTWO	Number of reference lines	1 bit 0/1	0: 3 lines 0: 2 lines
VLENGTH	Indication of possible use of NEWLEN marker segment	1 bit 0/1	Use of 0: NEWLEN not allowed Use of 1: NEWLEN allowed
TPDON	Use of TP for Typical Prediction for differential layers	1 bit 0 fixed	
TPBON	Use of TP for base layer	1 bit 0/1	0: OFF 1: ON
DPON	Use of Deterministic Prediction	1 bit 0 fixed	
DPPRIV	Use of private DP table	1 bit 0 fixed	Has meaning when DPON is 1.
DPLAST	Use of last DP table	1 bit 0 fixed	Has meaning when DPON is 1.

7.2.7 Explanation of bi-level image data (BID) section

BID is as shown in the construction figure below, and consists only of the number of stripes.

BID is constructed by the connection of the floating marker code and the section which includes the actual image data encoded with JBIG image compression encoding, called SDE (Stripe Data Entity).

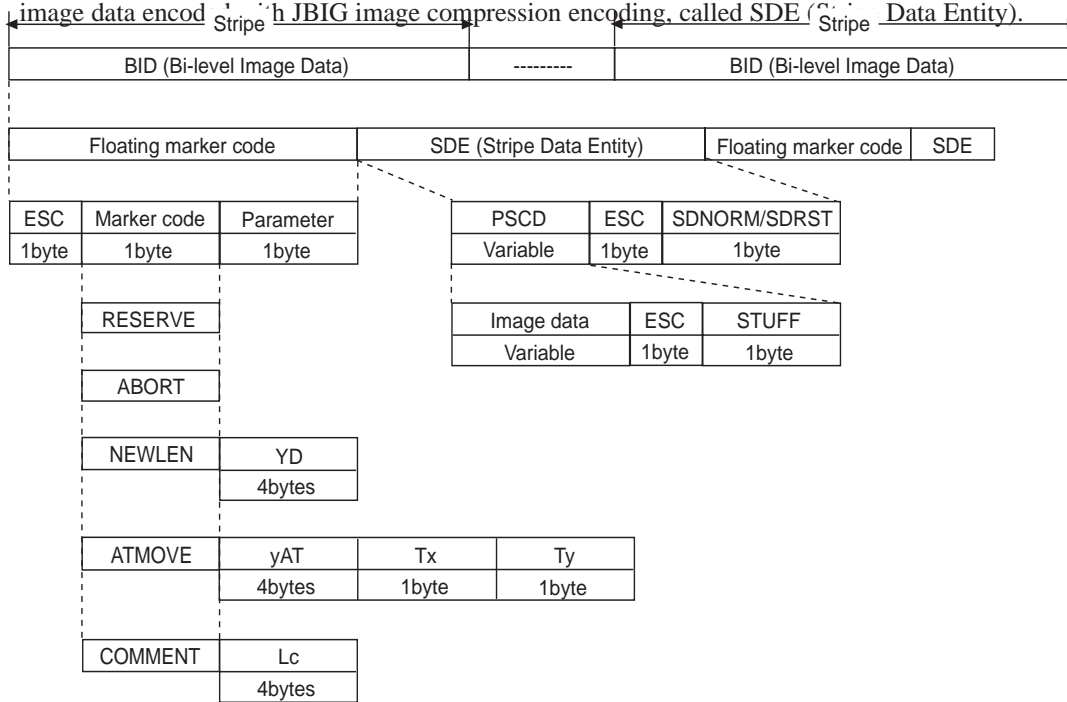

Figure 2-27 BID Construction Diagram

7.2.8 Explanation and parameters for each symbol used in BID

a) Floating marker code section

The floating marker code is set at the head of the stripe data entity (SDE).

In order to distinguish the encoding and the floating marker code, it is imperative that ESC (escape code: 0xFF) be set at the head.

The following marker code and parameters are in the floating marker code.

The 0x of each marker code shows that the following integers are hexadecimal.

ABORT (Abort: 0x05)

Encoding interruption. Only the abort code can be made to appear anywhere.

ESC	0x05
-----	------

ATMOVE (AT move: 0x06)

Designates from which line the movement of the AT pixel starts, and where it will move to.

ESC	0x06	yAT:Movement-starting line	Tx:Movement Position(X)	Ty:Movement Position (Y)
-----	------	----------------------------	-------------------------	--------------------------

COMMENT (Private comment: 0x07)

An optional comment may be added.

ESC 0x07 Lc:Comment length

NEWLEN (New length: 0x04)

Redefine the document length. Only usable when VLENGTH=ON.

ESC 0x04 YD:Document length

RESERVE (Reserve: 0x01)

Only usable for characteristic use.

ESC 0x01

b) Stripe data section

PSCD (Protected stripe encoding data)

The actual image data encoded with JBIG image compression is included in PSCD by the section remaining after the last 2 bytes from SDE, ESC and SDNORM or SDRST are omitted.

Image Data

The actual image data encoded with JBIG image compression.

STUFF

Image data is a variable, so STUFF:0 (zero) is adjusted by continuous sending so that the image data can be arranged into byte units or word (2 byte) units.

SDNORM (Stripe data completion: 0x02)

Shows the completion of stripe data

ESC 0x02

SDRST (The reset at completion of stripe data: 0x03)

Shows the completion of stripe data. Everything including the study table and the ATMOVE are reset.

ESC 0x03



NOTE

When the image data encoding is 0xFF, it is imperative to attach 0x00 after the image data encoding 0xFF in order to distinguish ESC(0xFF).

This page intentionally left blank

Chapter 3

Maintenance and Service

1. MAINTENANCE LIST

1.1 Consumables

Level	Consumable	When
User	Toner cartridge (FX3)	When "REPLACE CARTRIDGE" is displayed.
Service technician	None	

1.2 Cleaning

Level	Location	When
User	Main unit outer covers	When dirty.
	Separation roller	When document separation/ feed performance falls.
	Separation guide	When document separation performance falls.
	White sheet	When copied and transmitted images are faint.
	Scanning glass (contact sensor)	When black vertical stripes appear in copied or transmitted images.
	Paper feed guide or received images.	When marks appears on back of paper in copied
Service technician	Paper pickup roller	When recording paper feed performance falls.
	Transfer charging roller	When marks on back of paper or blank spots at intervals of 1.96" (50 mm) appear in copied or received images.
	Static charge eliminator	When polka appear dots in copied or received images.
	High-voltage terminal	When copied or received images are light, dark, or completely blank.

Level	Location	When
Service technician	Fixing entrance guide	When marks on back of paper, irregular/smudged black vertical line, paper jam, wrinkles in copied or received images.
	Paper face-up eject roller	When paper jams occur during copying or receiving.
	Flapper	When paper jams occur frequently during copying or receiving.
	Document feed roller	When document feed performance falls.
	Document eject roller	When document feed performance falls.
	Pressure roller	When marks appear on back of paper at intervals of 2.48" (63 mm), or poor fixing, paper jam, or wrinkles occur during copying or receiving.
	Fixing ass'y	When marks appear at intervals of 2.95" (75 mm) or poor fixing of copied or received images occurs.
	Separation pad	When recording paper separation performance falls.

1.3 Periodic Inspection

None

1.4 Periodic Replacement Parts

Level	Location	When
User	None	
Service technician	None	

1.5 Adjustment Items

None

1.6 General Tools

Tool	Use
Phillips screwdriver	Removing/inserting screws
Flat bladed screwdriver	Removing/inserting screws
Precision flat bladed screwdriver	Removing plastic tabs
Tweezers	Removing coil spring
Pliers, needle nose	Driving retaining ring
Lint-free paper	Clean transfer charging roller, fixing film
Isopropyl alcohol	Clean fixing entrance guide, fixing eject roller, fixing eject guide, static charge eliminator, etc.

1.7 Special Tools

Tool	Use	Part No.
Grease (MOLYKOTE EM-50L)	Apply to specified parts	HY9-0007
Grease (IF-20)	Apply to specified parts	CK-8006
Grease (UNIWAY 68)	Apply to specified parts	CK-0451

2. HOW TO CLEAN PARTS

2.1 Main Unit Outer Covers

Lightly wipe the unit's outer casing with a clean, soft, lint-free cloth moistened with water or diluted dishwashing detergent solution.

2.2 Separation Roller

Wipe with a soft, dry clean cloth.

2.3 Separation Guide

Wipe with a dry clean soft cloth.

2.4 White Sheet

Wipe with a soft, dry clean soft cloth.

2.5 Scanning Glass (Contact Sensor)

Wipe with a soft, dry clean cloth.

2.6 Paper Feed Guide

Wipe with a clean, soft, dry, lint-free cloth to remove any toner or paper debris.



Do not touch the transfer changing roller during cleaning. Otherwise, the print quality may deteriorate.



If Separation roller, Separation guide and Paper pickup roller are very dirty, wipe with a cloth moistened with Isopropyl alcohol (IPA). Do not use tissue paper. Dust from the tissue paper causes static electricity.

Precautions when using Isopropyl alcohol (IPA)

When cleaning with IPA, take care to prevent the IPA from splashing high-temperature parts. If IPA splashes high-temperature parts, leave for at least three minutes to allow the IPA to evaporate.

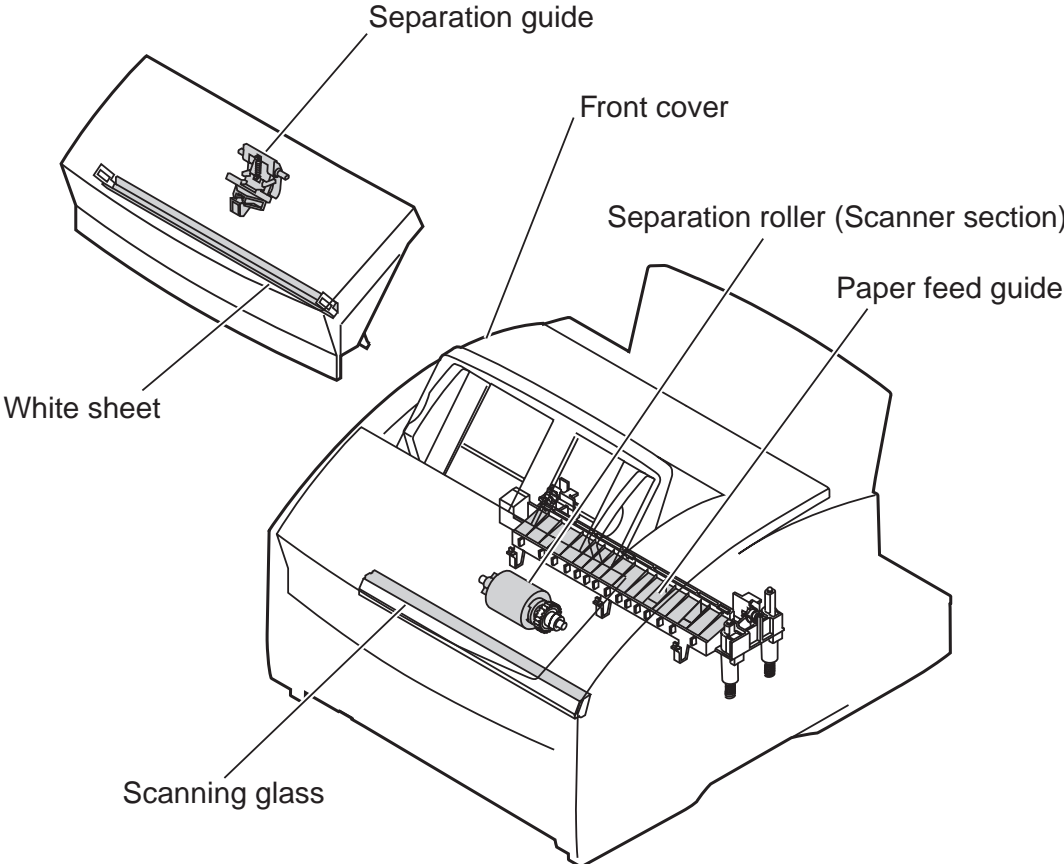

Figure 3-1 Cleaning Location 1

2.7 Paper Pickup Roller

Using lint-free paper dipped in isopropyl alcohol, wipe and dirt off the paper pickup roller.

2.8 Transfer Charging Roller

Wipe with lint-free paper and remove any toner or paper debris.



Do not touch or hold the sponge section of the transfer charging roller. Doing so can cause marks on back of paper or blank spots in copied or received images.

Never clean with solvents

Replace the charging roller if it is deformed or cannot be thoroughly cleared using lint-free paper.

2.9 Static Charge Eliminator

Wipe with a lint-free paper and remove any foreign matter, such as paper fragments.

2.10 High Voltage Terminal

Wipe with a clean, soft, dry, lint-free cloth to remove any toner or paper debris.

2.11 Fixing Entrance Guide

Wipe with a lint-free paper and remove any toner or paper debris.

2.12 Paper Face-up Eject Roller

Using lint-free paper dipped in isopropyl alcohol, wipe off the paper eject face-up roller.

2.13 Flapper

Wipe with a lint-free paper and remove any toner or paper debris.

2.14 Document Feed Roller, Document Eject Roller

Wipe with a soft, dry clean cloth.

2.15 Pressure Roller

Using lint-free paper dipped in alcohol, wipe off the pressure roller.

2.16 Fixing Ass'y

Using lint-free paper dipped in alcohol, wipe off the fixing ass'y.

2.17 Separation Pad

Using cloth dipped in isopropyl alcohol, wipe off the separation pad.

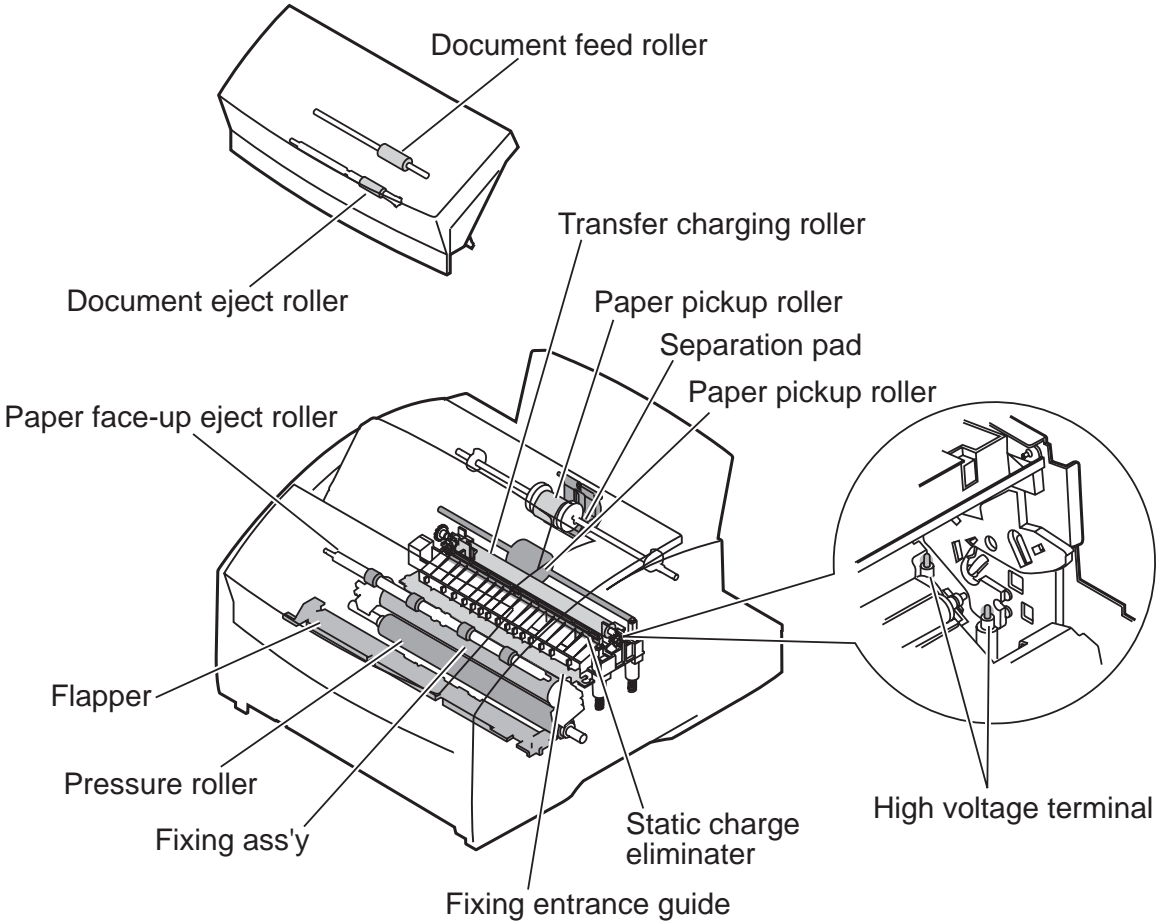

Figure 3-2 Cleaning Location 2

3. REPLACING PARTS & ADJUSTMENTS

3.1 Replacing Parts

For details on the disassembly/assembly procedure when replacing parts, refer to the Parts Catalog (separate). Illustrations in the Parts Catalog are drawn in the order in which parts are disassembled. The Parts Catalog also shows enlarged drawings or supplementary illustrations for parts requiring caution during disassembly and assembly. Particular care should be paid to the cautions contained in illustrations.

3.2 Adjustment

None

4. TROUBLESHOOTING

4.1 Troubleshooting Index

Use the troubleshooting index below to investigate the cause of a problem and refer to the specified page for countermeasures.

Problem

• General errors

- The unit does not power on. Page 3-18
- The display looks abnormal. Page 3-18
- The buttons do not work. Page 3-18
- No sound from the speaker Page 3-18

• Errors shown on the display

- User error message. Page 3-10
- Error codes. Page 3-12

• Printing problems (Evaluation criteria: Test printing is faulty.)

- The paper is not fed correctly. Page 3-19
 - The main motor does not run.
 - The paper is not picked up from the auto sheet feeder.
 - The paper skews.
- The printing operation is abnormal. Page 3-19
 - The unit indicates a paper jam when there is none.
- Poor printing quality Page 3-20
 - Light
 - Dark
 - Completely blank
 - All black
 - Dots
 - Marks on back of papers
 - Black vertical lines
 - Irregular and smudged black vertical lines
 - Irregular and smudged black horizontal lines
 - Marks
 - Blank spots
 - White vertical lines
 - White horizontal lines
 - Faulty registration
 - Distortion/BD signal failure
 - Partially compressed/stretched image
 - Poor fixing

• **Scanning problems (Evaluation criteria: Test printing is good, but the copied image is poor.)**

- The document is not fed. Page 3-25
 - The document feed motor does not run.
 - The document slips against the rollers.
 - The document does not separate.
 - The scanner unit's sensors are defective
- The scanning image is abnormal. Page 3-26
 - Nothing is printed.
 - The image has vertical stripes.
 - The image has thick vertical stripes.

4.2 Errors Shown on the Display

4.2.1 User error message

Look for the applicable error message and implement the appropriate countermeasures.

"BUSY/NO SIGNAL" (#005/#018)

- Cause:** The receiving fax did not answer within 55 seconds. (T0 time over)
- Solution:** Contact the other party and have them check their fax. You can try to send the document manually. For an overseas call, add pauses to the registered number.
- Cause:** The touch tone/rotary pulse setting on your fax is incorrect.
- Solution:** Set your fax to the setting that matches your telephone line.
- Cause:** The other party is not using a G3 machine.
- Solution:** Contact the other party and have them send or receive the document using a G3 machine.
- Cause:** The other party's fax is not working.
- Solution:** Contact the other party and have them check their fax.
- Cause:** The telephone number you dialed is busy.
- Solution:** Try sending the document at a later time.

"CHECK DOCUMENT" (#001)

- Cause:** Document jam. This is displayed when the document sensor detects paper, but the document edge sensor cannot detect the leading edge of the document with 15 seconds from the start of the feed operation.
- Solution:** Clear the document jam.

"CHECK PAPER SIZE"

- Cause:** The size of the paper loaded in the paper tray is different from the paper size set by the user data menu.
- Solution:** Set the correct paper size in the user data setting.

"CHECK PRINTER" (##322~##324, #335)

Check the displayed error code and see the measure to eliminate the error. (See Page 3-17.)

"DATA ERROR"

- Cause:** The registration data in the SRAM was destroyed and a checksum error occurred due to a dead lithium battery or SRAM failure.
- Solution:**
- (1) Press the *Set* button, and turn the power off and on again.
 - (2) Replace the lithium battery.
 - (3) Replace the SCNT board.

"DOC. TOO LONG" (#003)

- Cause:** The document is longer than 39.4"(1m).
Solution: Use a copy machine to make a reduced copy of the document, then send again.
Cause: It took more than 32 minutes to send, copy, a document or receive a document.
Solution: Divide the document and send or copy each part separately. Contact the other party and have them divide the document and send each part separately.

"HANG UP PHONE"

- Cause:** The handset or the extension telephone is off the hook.
Solution: Put the handset or the extension telephone back on the hook.

"MEMORY FULL" (#037)

- Cause:** The fax's memory is full because it has received too many documents.
Solution: (1) Print out any documents which are stored in memory. Then start the operation again.
(2) If the memory contains any facsimiles you don't need, delete them.
Cause: The fax's memory is full because you tried to send too many pages at once.
Solution: Divide the document and send each part separately.

"NO ANSWER" (#005)

- Cause:** The receiving fax machine does not answer.
Solution: Make sure you dialed the correct number. Try again later.

"NO RX PAPER" (#012)

- Cause:** The receiving fax machine declares no paper in DIS, or its memory is full.
Solution: Contact the other party, and ask them to put paper in their machine, or to clear their fax machine's memory.

"NO TEL #" (#022)

- Cause:** The button you pressed has no number registered for One-Touch Speed Dialing, Coded Speed Dialing, or Group Dialing.
Solution: Print a list of registered numbers and make any corrections needed, then try again.

"NOT AVAILABLE NOW"

- Cause:** One-touch or coded speed dial already registered.
Solution: Check the contents of the one-touch or coded speed dialing registration, then try again.

"CLEAR PAPER JAM" (#009)

- Cause:** Paper jam.
Solution: Clear the paper jam.

"REPLACE CARTRIDGE"

- Cause:** The toner cartridge has run out of toner.
Solution: Replace the toner cartridge.

"START AGAIN"

Cause: An error occurred on the phone line or in the system.
Solution: Start the procedure again from the beginning.

"LOAD PAPER"

Cause: The fax is out of paper.
Solution: Add more paper to the paper tray.

"CHECK COVER/CART"

Cause: The toner cartridge is not installed properly.
Solution: Make sure the toner cartridge is installed properly.
Cause: Front cover is not closed.
Solution: Close front cover.

4.2.2 Error codes

a) Service error code output

When service data #1 **SSSW SW01** bit 0 is set to "1", then service error codes are printed on the activity management reports, reception result reports and error transmission reports when communication is terminated due to an error. Also, the following is displayed when an error occurs.

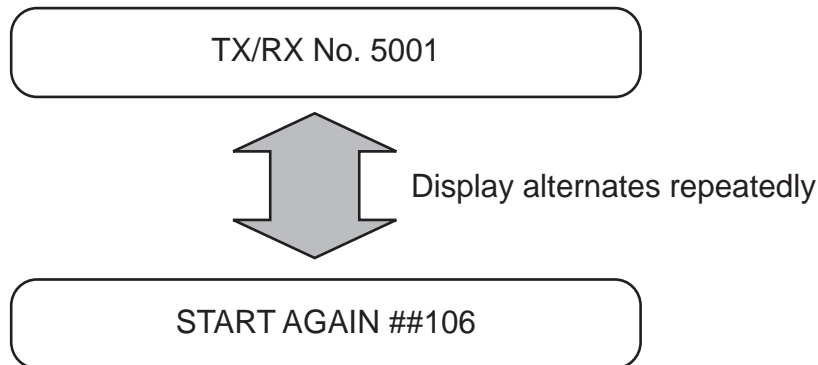

Figure 3-3 Service Error Code Display

b) Error code countermeasures

The following item c) lists all the error codes which the unit can display. The separate *G3 Facsimile Error Code List (Rev. 1)* does not specify the countermeasures for resolvable error codes. Also refer to this list when an error code appears.

The *G3 Facsimile Error Code List (Rev. 1)* does not specify countermeasures for all error codes. The countermeasures that are specified in the *G3 Facsimile Error Code List (Rev. 1)* are included here as specific countermeasures for your reference.

- **Increase the transmission level**

Increase service data **#2 MENU** Parameter No.07 toward 0 (dBm).

- **Decrease the transmission level**

Decrease service data **#2 MENU** Parameter No.07 toward -15 (dBm).

- **Echo measures**

Change the following bit switches of service data **#1 SSSW SW03**.

Bit 4:1 Ignore the first DIS signal sent by the other fax machine.

0 Do not ignore the first DIS signal sent by the other fax machine.

Bit 5:1 Transmit a tonal signal (1850 or 1650 Hz) when the other fax machine sends a DIS signal.

0 Do not transmit a tonal signal when the other fax machine sends a DIS signal.

Bit 6:1 Transmit a 1650-Hz tonal signal when bit 5 is 1.

0 Transmit a 1850-Hz tonal signal when bit 5 is 1.

Bit 7:1 Transmit a tonal signal before sending a CED signal.

0 Do not transmit a tonal signal before sending a CED signal.

- **EPT (Echo Protect Tone)**

Change service data **#1 SSSW SW03** bit 1.

Bit 1:1 Transmit an echo protect tone.

0 Do not transmit an echo protect tone.

- **Adjust NL equalizer.**

Set service data **#2 MENU** Parameter No.05 to "ON".

- **Reduce the transmission start speed.**

Reduce the transmission speed by changing "TX START SPEED" setting.

- **Loosen the TCF judgment standard.**

Not available for this fax.

- **Loosen the RTN transmission conditions.**

Change service data **#3 NUMERIC Param.** Parameters No.02 to 04.

No.02 Percentage of errors in all lines : Set close to 99%.

No.03 Number of lines of burst condition : Set close to 99 lines.

No.04 Number of burst line groups : Set close to 99 groups.

- **Increase the no-sound time after CFR reception.**

Change service data **#1 SSSW SW04** bit 4 to "1".

Bit 4: 1 Time when the low-speed signal is ignored after sending a CFR signal: 1500 ms

0 Time when the low-speed signal is ignored after sending a CFR signal: 700 ms

c) ERROR CODE LIST for FAX-L350

The error codes used for this fax are as follows.

Codes listed as “New” in the list below indicate new error codes, or codes whose measures differ from those listed in the separate document *G3 Facsimile Error Code List (Rev.1)*.

For recovery methods for error codes indicated as “New”, see the item *d) Recovery methods for codes indicated as “New” in this chapter, 5.2.2 Error codes.*

For items other than “New”, see the separate document *G3 Facsimile Error Code List (Rev.1)*.

• User error code

No.	Tx or Rx	Definition
#001	[TX]	Paper Jam
#003	[TX/RX]	Copy Page, Communication Time Over
#005	[TX/RX]	Initial ID (T1) Time Over
#009	[RX]	Recording Paper Jam or Out of Paper
#011	[RX]	Polling Error
#012	[TX]	Other party Out of Paper
#018	[TX/RX]	Automatic Dialing Error
#021	[RX]	DCN during Polling Rx
#022	[TX]	Call Failure
#037	[RX]	Image Memory Full
#039	[TX]	Closed Network Tx Failure
#995	[TX/RX]	Memory Communication reservation cancellation

• Service error code

No.	Tx or Rx	Definition
##100	[TX]	Excessive Repeat Protocol during Rx
##101	[TX/RX]	Modem Speed Different from Other Party
##102	[TX]	Fall Back Failure during Tx
##103	[RX]	Fail to Detect EOL for 5 Seconds (15 seconds for CBT) during Rx
##104	[TX]	RTN or PIN Received during Tx
##106	[RX]	Fail to Receive Protocol for 6 Seconds when Waiting for Protocol during Rx
##107	[RX]	Fall Back Failure on Tx Side during Rx
##109	[TX]	Receive Signals Other than DIS, DTC, FTT, CFR or CRP after DCS Tx and Exceed the Number of Protocol re-transmissions during Tx
##111	[TX/RX]	Memory error
##114	[RX]	RTN Transmission during Reception
##116	[TX/RX]	Detect Loop Current Disconnection during Communication
##200	[RX]	Fail to Detect Picture Rx Carrier for 5 Seconds during Rx
##201	[TX/RX]	DCN received Other than Normal Binary Protocol
##204	[TX]	Receive DTC without Tx Data
##220	[TX/RX]	System Error (main program runaway)
##224	[TX/RX]	Abnormal Protocol during G3 Communication
##226	[TX/RX]	Stack Pointer Not within RAM Range
##229	[RX]	Recording Unit Locked for 1 Minute
##232	[TX]	ENCODE Control Unit Malfunction
##237	[RX]	DECODE Control Unit Malfunction
##238	[RX]	PRINT Control Unit Malfunction
##261	[TX/RX]	System Error between Modem and SCNT
##280	[TX]	Excessive Repeat Protocol Command during Tx
##281	[TX]	Excessive Repeat Protocol Command during Tx
##282	[TX]	Excessive Repeat Protocol during Tx
##283	[TX]	Excessive Repeat Protocol during Tx

No.	Tx or Rx	Definition
##284	[TX]	DCN Reception after TCF Transmission
##285	[TX]	DCN Reception after EOP Transmission
##286	[TX]	DCN Reception after EOM Transmission
##287	[TX]	DCN Reception after MPS Transmission
##288	[TX]	Receive Signals Other than PIN, PIP, MCF, RTP or RTN after EOP Transmission
##289	[TX]	Receive Signals Other than PIN, PIP, MCF, RTP or RTN after EOM Transmission
##290	[TX]	Receive Signals Other than PIN, PIP, MCF, RTP or RTN after MPS Transmission
##322	[RX]	Printer (LBP) Fixing Unit Trouble
##323	[RX]	Printer (LBP) BD (Beam Detect) Trouble
##324	[RX]	Printer (LBP) Scanner Trouble
##670	[TX]	At V.8 late start, the called party declares the V.8 protocol in DIS signal and this unit transmits a CI signal, but the protocol does not progress and a T1 time-out occurs.
##671	[RX]	At V.8 termination, the protocol did not advance to phase 2 and a T1 time-out occurs after the caller CM signal was detected.
##672	[TX]	The protocol did not move from phase 2 to phase 3 and a T1 time-out occurred during V.34 transmission.
##673	[RX]	The protocol did not move from phase 2 to phase 3 and a T1 time-out occurred during V.34 reception.
##674	[TX]	The protocol did not move from phase 3 to phase 4 and a T1 time-out occurred during V.34 transmission.
##675	[RX]	The protocol did not move from phase 3 to phase 4 and a T1 time-out occurred during V.34 reception.
##750	[TX]	Exceed Repeat Protocol Due to Failure to Receive Significant Signals after Transmitting PPS-NULL during ECM Tx
##752	[TX]	Receive DCN after PPS-NULL Transmission during ECM Tx
##753	[TX]	Exceed Protocol Retransmission Limit or T5 Time (60 seconds) after PPS-NULL Transmission during ECM Tx
##754	[TX]	Exceed Retransmit Protocol after PPS-NULL Transmission during ECM Tx
##755	[TX]	Exceed Protocol Retransmission Limit Due to Failure to Receive Significant Signals after PPS-MPS Transmission during ECM Tx
##757	[TX]	Receive DCN after PPS-MPS Transmission during ECM Tx
##758	[TX]	Exceed Protocol Retransmission Limit or T5 Time (60 seconds) after PPS-MPS Transmission during ECM Tx
##759	[TX]	Exceed Retransmit Protocol after PPS-MPS Transmission during ECM Tx
##760	[TX]	Exceed Protocol Retransmission Limit Due to Failure to Receive Significant Signals after PPS-EOM Transmission during ECM Tx
##762	[TX]	Receive DCN after PPS-EOM Transmission during ECM Tx
##763	[TX]	Exceed Protocol Retransmission Limit or T5 Time (60 seconds) after PPS-MPS Transmission during ECM Tx
##764	[TX]	Exceed Retransmit Protocol after PPS-EOP Transmission during ECM Tx
##765	[TX]	Exceed Protocol Retransmission Limit Due to Failure to Receive Significant Signals after PPS-EOP Transmission during ECM Tx
##767	[TX]	Receive DCN after PPS-EOP Transmission during ECM Tx

No.	Tx or Rx	Definition
##768	[TX]	Exceed Protocol Retransmission Limit or T5 Time (60 seconds) after PPS-EOP Transmission during ECM Tx
##769	[TX]	Exceed Retransmit Protocol after PPS-EOP Transmission during ECM Tx
##770	[TX]	Exceed Repeat Protocol Limit Due to Failure to Receive Significant Signals after Transmitting EOR-NULL during ECM Tx
##772	[TX]	Receive DCN after EOR-NULL Transmission during ECM Tx
##773	[TX]	Exceed Protocol Retransmission Limit or T5 Time (60 seconds) after EOR-NULL Transmission during ECM Tx
##774	[TX]	Receive ERR after EOR-NULL Transmission during ECM Tx
##775	[TX]	Exceed Protocol Retransmission Limit Due to Failure to Receive Significant Signals after EOR-MPS Transmission during ECM Tx
##777	[TX]	Receive DCN after EOR-MPS Transmission during ECM Tx
##778	[TX]	Exceed Protocol Retransmission Limit or T5 Time (60 seconds) after EOR-MPS Transmission during ECM Tx
##779	[TX]	Receive ERR after EOR-MPS Transmission during ECM Tx
##780	[TX]	Exceed Protocol Retransmission Limit Due to Failure to Receive Significant Signals after EOR-EOM Transmission during ECM Tx
##782	[TX]	Receive DCN after EOR-EOM Transmission during ECM Tx
##783	[TX]	Exceed Protocol Retransmission Limit or T5 Time (60 seconds) after EOR-EOM Transmission during ECM Tx
##784	[TX]	Receive ERR after EOR-EOM Transmission during ECM Tx
##785	[TX]	Exceed Protocol Retransmission Limit Due to Failure to Receive Significant Signals after EOR-EOP Transmission during ECM Tx
##787	[TX]	Receive DCN after EOR-EOP Transmission during ECM Tx
##788	[TX]	Exceed Protocol Retransmission Limit or T5 Time (60 seconds) after EOR-EOP Transmission during ECM Tx
##789	[TX]	Receive ERR after EOR-EOP Transmission during ECM Tx
##790	[RX]	Transmit ERR after EOR-Q Reception during ECM Rx
##791	[TX/RX]	Receive Non-Significant Signals during ECM Mode Procedures
##792	[RX]	Fail to Detect PPS-NULL between Partial Pages during ECM Rx
##793	[RX]	Time Over Due to Failure to Receive Valid Frame during High Speed Signal Rx upon ECM Rx
##794	[TX]	Receive All 0 PPR during ECM Tx
##795	[TX/RX]	Trouble in the decoding processing during communication

d) New error codes and recovery methods

There is no new error code in this model.

Note, however, the following supplementary information, as the machine requires different actions than the existing models to correct:

##322 [TX/RX] Fixing heater temperature abnormality

Cause: Internal unit defect.

- Solutions:**
- (1) Check the connections between the fixing ass'y and the PCNT board (J2) and between the fixing ass'y and the power supply unit (J102).
 - (2) Check the connection between the PCNT board (J403) and the power supply unit (J202).
 - (3) Check the resistance between connector pins of the fixing ass'y.
 J203-12 and J203-13: 790 to 212 k Ω (at 10 ~ 35°C)
 J102-1 and J102-2: 120.9 to 139.1 Ω (at 25°C)
 If either resistance is incorrect, replace the fixing ass'y.
 - (4) Check the voltage at J102 of the power supply unit (with the heater cable TB1 removed); if it is not the same as the AC input voltage, replace the power supply unit.
 - (5) Replace the PCNT board.
 - (6) Replace the SCNT board.

##323 [TX/RX] LASER/scanner section BD signal output abnormal

Cause: Internal unit defect (Low LASER intensity)

- Solutions:**
- (1) Check the connection between the LASER/scanner section (J801) and the SCNT board (J502).
 - (2) Replace the LASER/scanner section.
 - (3) Replace the SCNT board.

Cause: Internal unit defect (BD signal timing error)

- Solutions:**
- (1) Check the connection between the LASER/scanner section (J801) and the SCNT board (J502).
 - (2) Replace the LASER/scanner section.
 - (3) Replace the SCNT board.

##324 [TX/RX] Printer section scanner motor rotation rate abnormal

Cause: Internal unit defect (Incorrect scanner motor speed)

- Solutions:**
- (1) Check the connection between the LASER/scanner section (J1) and the SCNT board (J502).
 - (2) Replace the LASER/scanner section.
 - (3) Replace the SCNT board.

##335 [TX/RX] Data communication error between system control section and printer control section

Cause: Internal unit defect

- Solutions:**
- (1) Check the connections between the PCNT board (J1) and the SCNT board (J3) and between the SCNT board (J2) and power supply unit (J201).
 - (2) Replace the SCNT board.
 - (3) Replace the PCNT board.
 - (4) Replace the power supply unit.

4.3 Errors not Shown on the Display

4.3.1 General errors

- **The unit does not power on. (Evaluation criteria: Look at the actual unit.)**

- (1) Check the power cord connection.
- (2) Check the connection between the SCNT board (J2) and power supply unit (J201).
- (3) Check the power supply unit's fuse (FU101).
- (4) Replace the power supply unit.

- **Abnormal display. (Applicable test mode: Operation panel test)**

- Nothing is displayed.**

- (1) Check the connection between the operation panel unit and SCNT board (J406).
- (2) Replace the operation panel unit.
- (3) Replace the SCNT board.

- Part of the LCD panel does not display anything.**

- (1) Check for LCD problems with the test mode.
- (2) Check the connection between the operation panel unit and SCNT board (J406).
- (3) Replace the operation panel unit. (Faulty LCD)
- (4) Replace the SCNT board.

- **The buttons do not work. (Applicable test mode: Operation panel test)**

- (1) If the test mode can be used, check for faulty buttons.
- (2) Check the connection between the operation panel unit and SCNT board (J406).
- (3) Replace the operation panel unit.
- (4) Replace the SCNT board.

- **No sound from the speaker**

- (1) Check the connection of the speaker and SCNT board (J7).
- (2) Replace the speaker.
- (3) Replace the SCNT board.

4.3.2 Printing problems

- **Faulty printing (Evaluation criteria: Test print is faulty.)**

- **The paper is not fed correctly. (Evaluation criteria: Look at the actual unit.)**

The main motor does not run.

- (1) Check the voltage (+12 V) at both terminals of C501 located on the MCNT board.
- (2) Check the main motor's resistance. 1.62 ~ 1.98 Ω/1 phase is normal. (Fig. 3-4)
- (3) Replace the main motor.
- (4) Replace the SCNT board.
- (5) Replace the MCNT board.

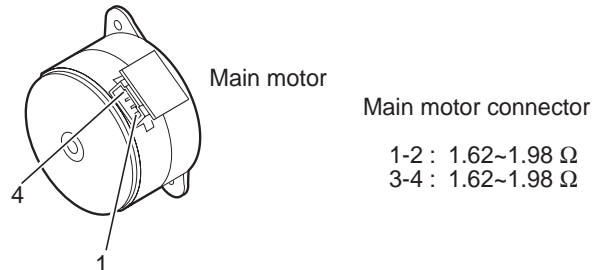

Figure 3-4 Main Motor Connector

The paper is not picked up from the auto sheet feeder/cassette.

- (1) Check whether the recommended paper is used.
- (2) Check whether more than 100 sheets (0.39" (10 mm)) or less of paper have been loaded in the auto sheet feeder, be sure that the curling, if any, appreciable.
- (3) Check whether more than 250 sheets (1.08" (27.5 mm)) or less of paper have been loaded in the cassette.
- (4) Check whether the paper has been loaded into the sheet feeder correctly.
- (5) Check the connection between the paper pickup solenoid and the MCNT board (J501/J508).
- (6) Replace the paper pickup solenoid.
- (7) Clean the separation pad.
- (8) Replace the separation pad.
- (9) Replace the separation pad spring or the lifting spring.
- (10) Replace the SCNT board.

The paper skews.

- (1) Check whether the recommended paper is used.
- (2) Check whether more than 100 sheets (0.39" (10 mm)) or less of paper have been loaded in the auto sheet feeder, be sure that the curling, if any, appreciable.
- (3) Check whether more than 250 sheets (1.08" (27.5 mm)) or less of paper have been loaded in the cassette.
- (4) Check whether the paper has been loaded into the sheet feeder correctly.
- (5) Check whether dust or paper debris have built up inside the auto sheet feeder.
- (6) Check whether the paper pickup roller, or any other rollers, are damaged or scratched.

- **The printing operation is abnormal.**

The unit indicates there is a paper jam when there is no paper jam.

- (1) Check the connection from the paper edge sensor to the SCNT board (J507).
- (2) Check whether the paper edge sensor and actuator and the paper eject sensor actuator are in their correct positions.
- (3) In test mode check whether the paper edge sensor and the paper eject sensor are operating correctly.
- (4) Check the connection between the main motor and the SCNT board (J507).
- (5) Replace the main motor.
- (6) Replace the SCNT board.

• **Poor printing quality (Evaluation criteria: Check the test print image's faults.)**

Before checking for the cause of print defects, check whether the user uses Canon-recommended paper and stores it correctly. If the problem is solved by using the recommended paper, the customer should be advised to use the recommended paper and store it correctly.

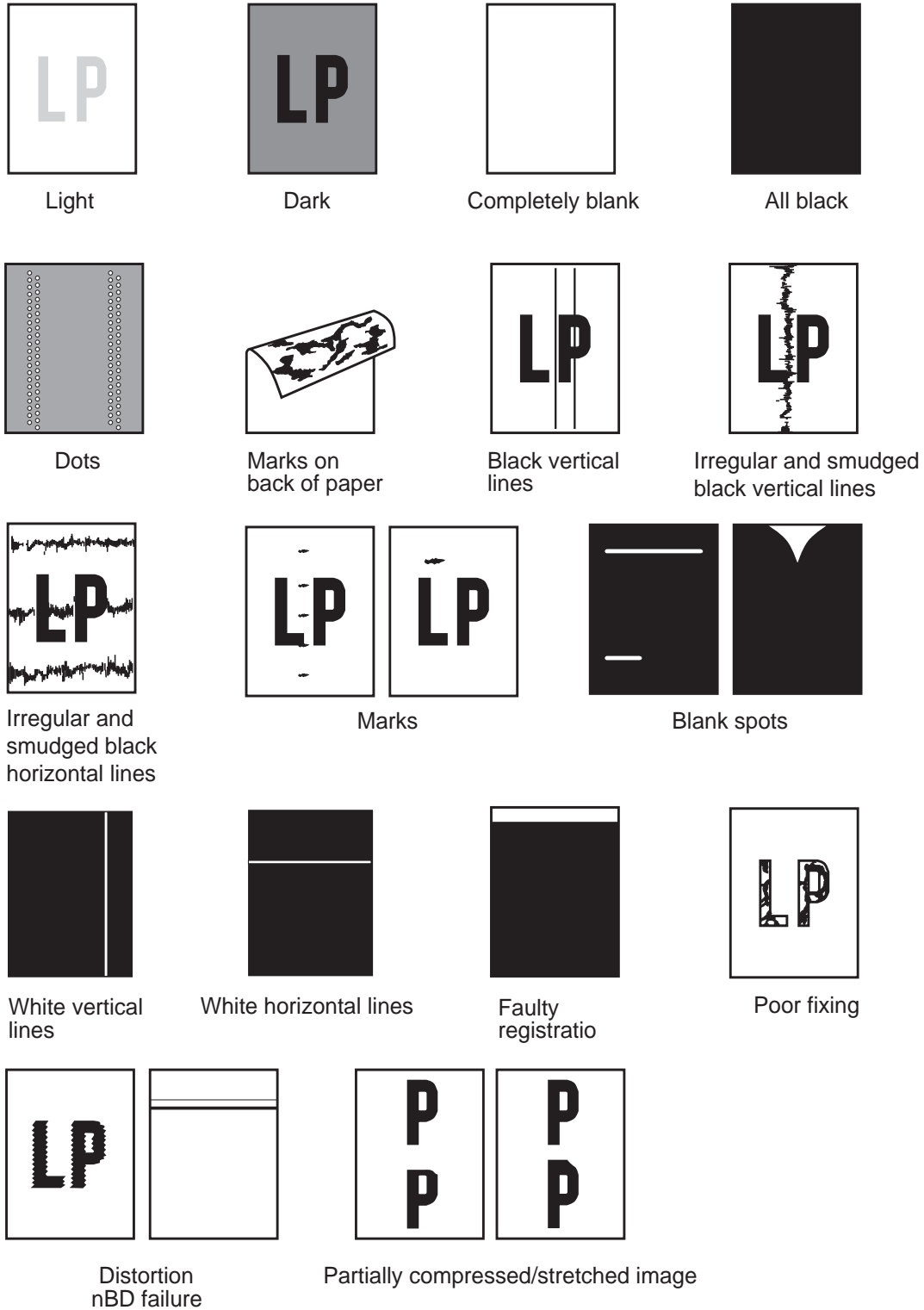

Figure 3-5 Faulty Print Samples

• **Light**

-
- Solutions:**
- (1) Remove the toner cartridge and shake it lightly five or six times.
 - (2) Verify that user setting “**ECONOMY PRT**” is not “**ON**”.
 - (3) Replace the toner cartridge.
 - (4) Open the front cover during printing, and remove the toner cartridge. Open the cartridge drum cover shutter manually, and check whether the toner image on the photosensitive drum is transferred onto the paper. If it is transferred, go to item (7). If not, go the following step.
 - (5) Clean the transfer bias contact and the transfer charging roller shaft contact.
 - (6) Replace the transfer charging roller.
 - (7) Clean the developing bias contact and the toner cartridge contact.
 - (8) Replace the PCNT board.
 - (9) Replace the LASER/scanner section.
 - (10) Replace the SCNT board.

• **Dark**

-
- Solutions:**
- (1) Verify that user setting “**ECONOMY PRT**” is not “**OFF**”.
 - (2) Clean the drum ground contact and the toner cartridge contact
 - (3) Clean the primary charging contact and the toner cartridge contact.
 - (4) Replace the LASER/scanner section.
 - (5) Replace the SCNT board.

• **Completely blank**

-
- Solutions:**
- (1) Clean the developing bias contact and the toner cartridge contact.
 - (2) Check whether the projection for opening and closing the LASER shutter on the toner cartridge is damaged.
 - (3) Check the voltage connector (MCNT : J503/J5, SCNT : J501/J3) for the high-voltage power circuit.
 - (4) Replace the PCNT board.
 - (5) Replace the LASER/scanner section.
 - (6) Replace the SCNT board.

• **All black**

-
- Solutions:**
- (1) Replace the toner cartridge.
 - (2) Clean the primary charging contact and the toner cartridge contact.
 - (3) Replace the PCNT board.
 - (4) Replace the LASER/scanner section.
 - (5) Replace the SCNT board.

• **Dots**

-
- Solutions:**
- (1) Clean the static charge eliminator in the toner transfer section.
 - (2) Check the static charge eliminator contact.
 - (3) Clean the transfer charging roller.
 - (4) Replace the transfer charging roller.

• Marks on back of paper

- Solutions:**
- (1) Copy a few white paper documents.
 - (2) If the marks are at intervals of approx. 50mm (1.96"), clean the transfer charging roller, but if they are at intervals of approx. 63mm (2.48"), clean the pressure roller.
 - (3) Clean the paper feed guide and fixing entrance guide.
 - (4) Replace the transfer charging roller.
 - (5) Replace the pressure roller.

• Black vertical lines

- Solutions:**
- (1) Open the front cover during printing, and remove the toner cartridge. Open the cartridge drum cover shutter manually, and check whether there are black vertical lines on the photosensitive drum. If there are black lines, replace the toner cartridge. If not, go the following step.
 - (2) Clean the face-down eject roller.
 - (3) Clean the fixing entrance guide.
 - (4) Replace the fixing ass'y.

• Irregular and smudged black vertical lines

- Solutions:**
- (1) Clean the fixing entrance guide.
 - (2) Replace the toner cartridge.

• Irregular and smudged black horizontal lines

- Solutions:** If the irregular smudged black lines occur cyclically, replace the toner cartridge. If they are non-cyclical, replace the fixing ass'y.

• Marks

- Solutions:**
- (1) If the marks are at intervals of approx. 50mm (1.96"), clean the transfer charging roller; if they are at intervals of approx. 75mm (2.95"), clean the fixing ass'y; and if they are at intervals of approx. 75mm (2.95"), or 38mm (1.5"), replace the toner cartridge.
 - (2) Clean the paper feed guide.
 - (3) Clean the fixing entrance guide.

• Blank spots

- Solutions:**
- (1) Clean the transfer charging roller.
 - (2) Replace the transfer charging roller.
 - (3) Replace the toner cartridge.
 - (4) Check for foreign matter between the transfer charging roller gear and the drive gear.
 - (5) Clean the developing bias contact and the toner cartridge contact.
 - (6) Replace the PCNT board.
 - (7) Replace the SCNT board.

• White vertical lines

- Solutions:**
- (1) Remove the toner cartridge and shake it lightly five or six times.
 - (2) Open the toner cartridge drum shutter and if there are vertical white lines on the photosensitive drum, replace the toner cartridge.
 - (3) Check for foreign matter stuck in the LASER output hole on the LASER/scanner section or the LASER input hole on the toner cartridge.
 - (4) Clean the face-up eject roller.
 - (5) Clean the fixing entrance guide.
 - (6) Replace the fixing ass'y.
 - (7) Replace the LASER/scanner section.

• White horizontal lines

- Solutions:**
- (1) Replace the toner cartridge.
 - (2) Replace the fixing ass'y.

• Faulty registration

- Solutions:**
- (1) Check if more than the regulation amount of paper is loaded in the sheet feeder.
 - (2) Clean the paper pickup roller.
 - (3) Replace the paper pickup roller.
 - (4) Check whether the paper edge sensor actuator is damaged or deformed.
 - (5) Replace the pickup solenoid.
 - (6) Replace the paper edge sensor.
 - (7) Replace the SCNT board.

• Distortion/BD signal failure

- Solutions:**
- (1) Check the connection between the LASER/scanner section and SCNT board (J502) connector connections.
 - (2) Replace the LASER/scanner section.
 - (3) Replace the SCNT board.

• Partially compressed/stretched image

- Solutions:**
- (1) Check for foreign matter between the toner cartridge gear and the drive gear.
 - (2) Check if the toner cartridge gear is broken.
 - (3) Replace the toner cartridge.

• Poor fixing

- Solutions:**
- (1) If the marks are at intervals of approx. 75mm (2.95"), clean the fixing ass'y; if they are at intervals of approx. 63mm (2.48"), clean the pressure roller.
 - (2) Replace the fixing ass'y.
 - (3) Replace the pressure roller.
 - (4) See the next page, and check the nip width of the fixing section. If it is not as specified, replace the fixing pressure plate.

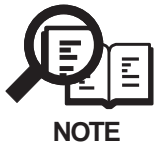

Checking the fixing nip width

Improperly set fixing nip may cause a fixing ass'y problem. The fixing ass'y is not designed to allow adjustment of the nip.

Check the fixing ass'y nip by using the following procedure.

- (1) Either take along one or two all-black copies of A4 or letter size made with a copier, or make one using a copier at the customer site.
- (2) Set the black copy in the sheet feeder with the black side facing up.
- (3) Change the paper delivery selector to the face-up delivery slot.
- (4) Enter the test mode and run **[3] PRINT, [6] ENDURANCE**.
- (5) Turn the power off when the beginning of the paper appears in the face-up delivery slot. Turn the power off, wait for 10 seconds, and remove the paper from the face-up delivery slot slowly.
- (6) Measure the widths of the areas on the paper where toner luster is visible and check whether they fall within the range shown in below table.

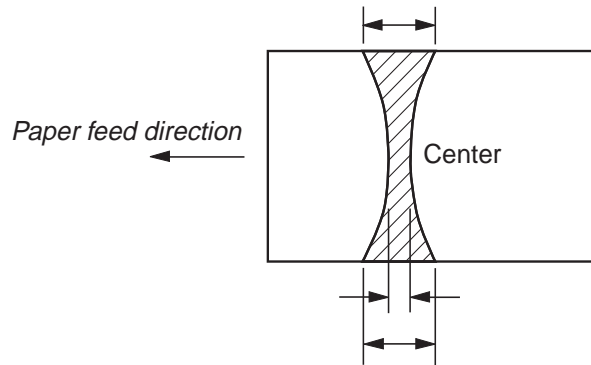

	Dimension
b	3.0 to 5.0 mm (0.12" to 0.20")
a - c	0.5 mm (0.02") or less
a - b	1.0 mm (0.04") or less
b - c	1.0 mm (0.04") or less

Figure 3-6 Fixing Nip Width

4.3.3 Scanning problems

- **Faulty scanning (Evaluation criteria: Test print is good, but the copied image is poor.)**
- **The document is not fed.**

The document feed motor does not run. (Evaluation criteria: Check it visually.)

- (1) Check the voltage (+12 V) at both terminals of C501 located on the MCNT board.
- (2) Check the connection between the document feed motor and the SCNT board (J406).
- (3) Check the document feed motor's resistance. 5.6 ~ 6.8 Ω /1 phase is normal. (Fig. 3- V)7)
- (4) Replace the document feed motor.
- (5) Replace the SCNT board.

The document slips against the rollers. (Evaluation criteria: Check it visually. Stretched copy image.)

- (1) See *page 3-4* and clean the document reading section.
- (2) Replace the reading section's rollers.

The document does not separate. (Evaluation criteria: Check it visually.)

- (1) Check whether the document feed motor is driving all the rollers. (Check for any damaged gears or foreign matter stuck inside.)
- (2) Check whether the document feed lever is set to manual document feed.
- (3) See *page 3-4* and clean the separation roller and separation guide.
- (4) Replace the separation roller and separation guide.

The scanner unit's sensors are defective (Evaluation criteria: The placed document or transported document is not detected.)

- (1) Check for any faulty sensors while executing the copying operation and test mode.
- (2) Check the connection between the operation panel unit and the SCNT board (J406).
- (3) Replace operation panel unit.
- (4) Replace the SCNT board.

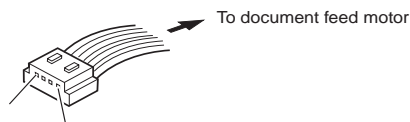

Document feed motor connector

1-2 : 5.6~6.8 Ω
 3-4 : 5.6~6.8 Ω

Figure 3-7 Document Feed Motor Connector

- **The reading image is abnormal. (Evaluation criteria: Check the copy image's faults.)**

Nothing is printed.

- (1) Check the connection between the contact sensor and SCNT board (J1).
- (2) Replace the contact sensor unit.
- (3) Replace the SCNT board.

The image has vertical stripes.

- (1) Clean the contact sensor's scanning glass.
- (2) Check the connection between the contact sensor and SCNT board (J1).
- (3) Replace the contact sensor unit.

The image has thick vertical stripes.

- (1) Clean the contact sensor's scanning glass.
- (2) Check the connection between the contact sensor and SCNT board (J1).
- (3) Replace the contact sensor unit.

5. SERVICE SWITCHES

5.1 Hardware Switches

There is a slide switch on the NCU board that must be set for each country.

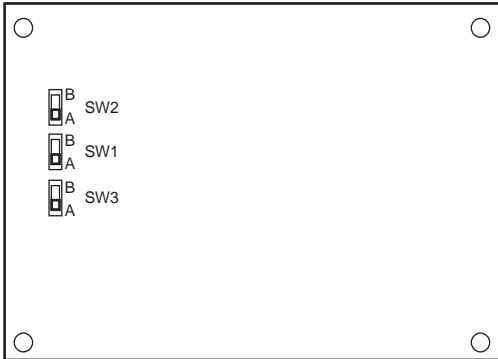

Nation	SW No.		
	1	2	3
U.K., FRN, AE, AUS, CHINA, N.Z.	B	A	B
SWEDEN	A	B	A
OTHERS (in CENV territory)	A	A	A

Figure 3-8 Slide Switch Location on NCU and Switch Settings

5.2 Service Data Settings

Service data can be checked and changed with items on display menus. The default values of the SSSW/parameters available in this fax machine are shown in *this Chapter, 5.2.3 Service data settings* in this manual. The SSSW/parameters given in the previous product-specific manual are explained in the *G3 Facsimile Service Data Handbook*. The new switches for this model are described in *this Chapter, 5.2.3 Service data settings*.

5.2.1 Service data overview

The service data menu items are divided into the following ten blocks.

#1 SSSW (Service Soft Switch settings)

These setting items are for basic fax service functions such as error management, echo countermeasures, and communication trouble countermeasures.

#2 MENU (MENU switch settings)

These setting items are for functions required during installation, such as NL equalizer and transmission levels.

#3 NUMERIC Param. (NUMERIC parameter settings)

These setting items are for inputting numeric parameters such as the various conditions for the FAX/TEL switching function.

#4 NCU (NCU settings)

These setting items are for telephone network control functions such as the selection signal transmission conditions and the detection conditions, for the control signals sent from the exchange.

#5 TYPE (TYPE setting)

The type setting makes the service data conform to a specific nation's communications standards.

#6 GENESIS (UHQ function setting)

These setting items are for scanned image processing functions such as edge enhancement and error diffusion processing.

#7 PRINTER (PRINTER function settings)

These setting items are for basic printer service functions such as the reception picture reduction conditions. Also there is an item for resetting the printer section without switching the power off-on.

#8 CLEAR (data initialization mode)

Various data are initialized by selecting one of these setting items. There is a setting item for checking/inputting the total number of pages printed and total number of pages scanned by this fax.

#9 ROM (ROM management)

ROM data such as the version number and checksum are displayed.

5.2.2 Service data registration/setting method

Service data can be registered and set by the following operations:

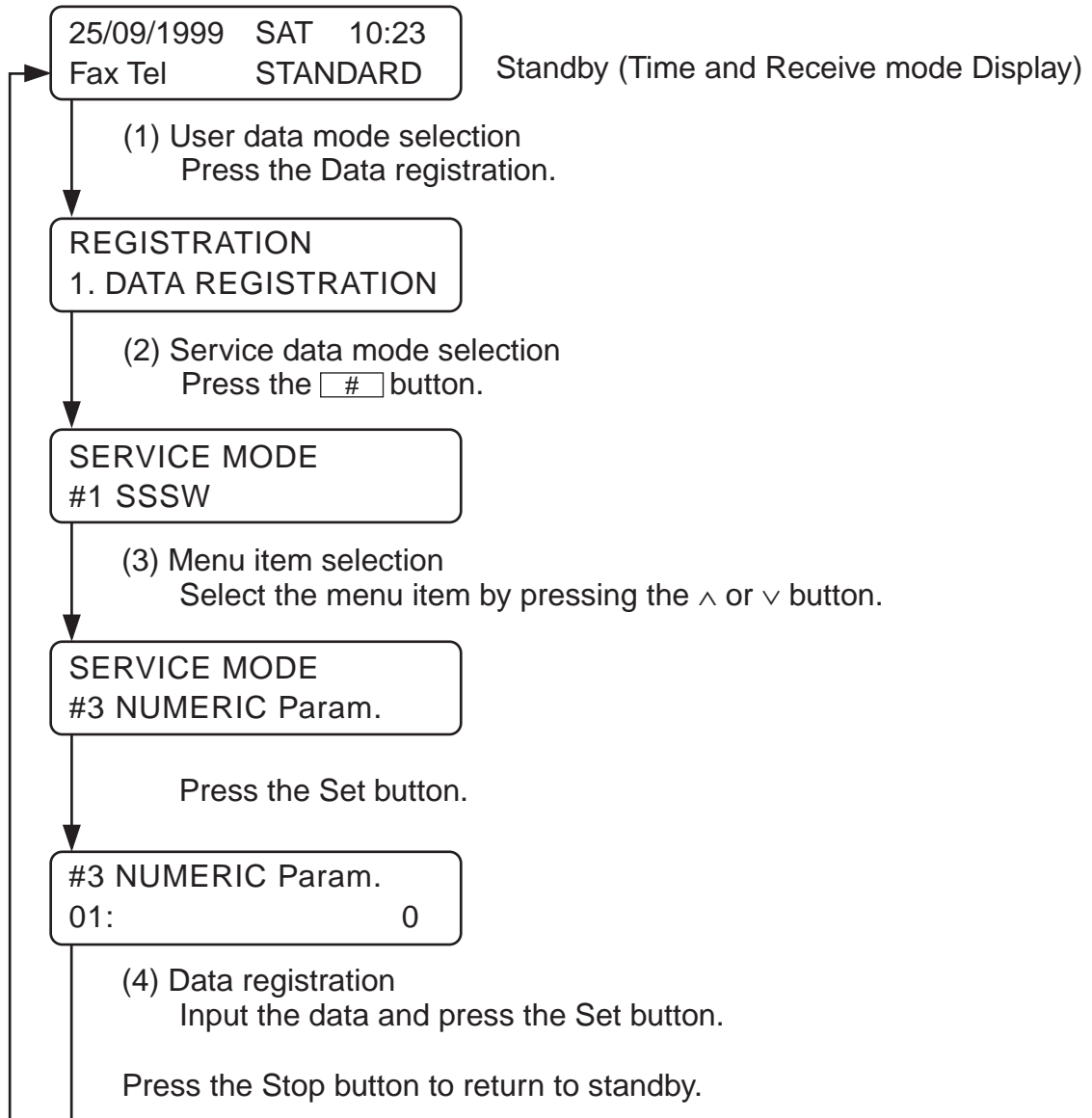

Figure 3-9 Service Data Setting Method



When using service mode, detach the telephone line from the main unit. Proper reception cannot be guaranteed when using service mode.

5.2.3 Service data settings

Service data

◀ ↔ ▶

#1 SSSW (Service soft switch setting)	Bit	7	6	5	4	3	2	1	0	
SW01	0	0	-	1	0	-	0	0		Error management
SW02	-	-	-	-	-	-	-	-	0	Memory clear list output setting
SW03	0	0	0	0	-	-	0	-		Echo solution setting
SW04	1	0	0	0	0	0	0	0		Communication trouble solution settings
SW05	-	-	0	0	0	-	-	-		Standard function (DIS signal) setting
SW06	-	-	0	-	-	-	0	0		Scan condition settings
SW07	-	-	-	-	-	-	-	-		Not used
SW08	-	-	-	-	-	-	-	-		Not used
SW09	-	-	-	-	-	-	0	0		Communications result display function settings
SW10	-	-	-	-	-	-	-	-		Not used
SW11	-	-	-	-	-	-	-	-		Not used
SW12	0	-	0	0	0	0	1	0		Page timer settings
SW13	-	-	-	-	-	-	-	-		Not used
SW14	-	-	-	-	-	-	-	-		Not used
SW15	-	0	-	-	-	-	-	-		Dial inn FAX/TEL switching function setting
SW16	-	-	-	-	-	-	-	-		Not used
SW17	-	-	-	-	-	-	-	-		Not used
SW18	-	-	-	-	-	-	0	0		Communication trouble solutions settings (2)
SW19	-	-	-	-	-	-	-	-		Not used
SW20	-	-	-	-	-	-	-	-		Copy function settings
SW21	-	-	-	-	-	-	-	-		Not used
SW22	-	-	-	-	0	-	-	-		Field Requests/Troubleshooting Issues
SW23	-	-	-	-	-	-	-	-		Not used
SW24	-	-	-	-	-	-	-	-		Not used
SW25	-	-	-	-	-	-	0	0		Report display function settings
SW26	0	0	-	-	0	-	-	0		Transmission function settings
SW27	-	-	-	-	-	-	-	-		Not used
SW28	-	-	0	0	0	0	0	0		V.8/V.34 protocol settings
SW29	-	-	-	-	-	-	-	-		Not used
SW30	-	-	-	-	-	-	-	-		Not used

↑
↓

Figure 3-10 Service Data (page 1)



The switches marked “-” are not used. Do not change their settings.

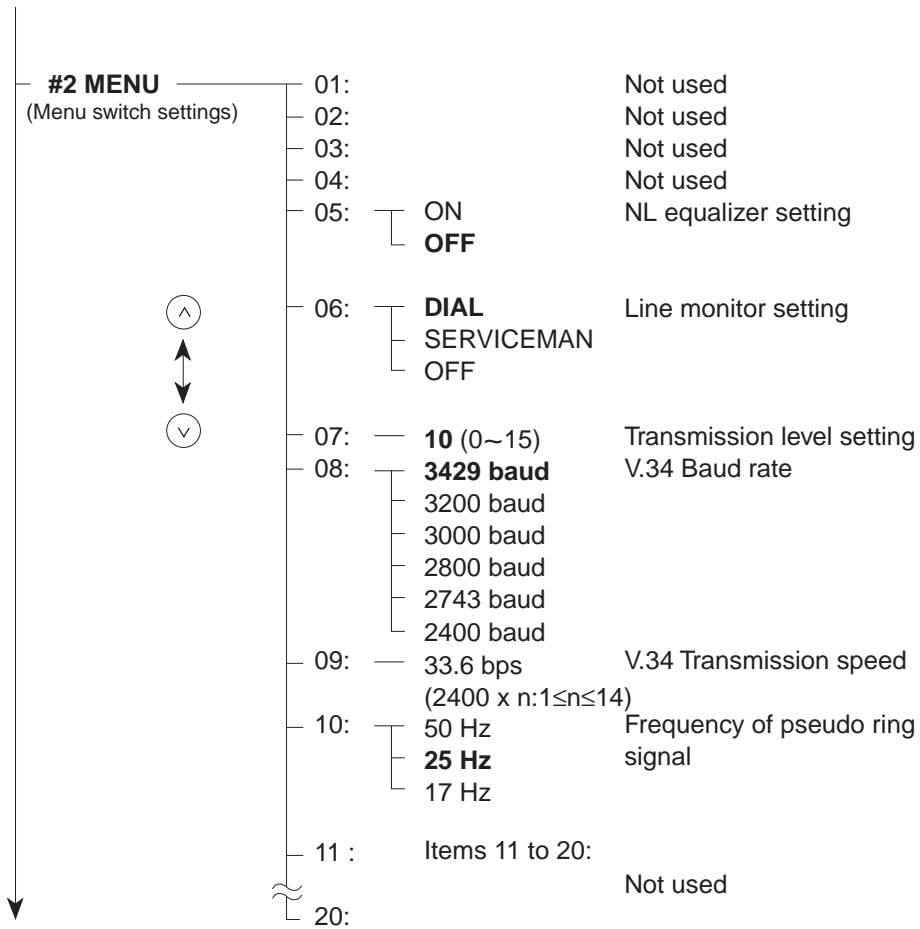

Figures in boldface indicate the default setting.

Figure 3-11 Service Data (page 2)



No. 01 to 04, 11 to 20 are not used. Do not change their settings.

#3 NUMERIC Param. (Numeric parameter settings)			
	Default	Range	
01:	0		Not used
02:	10 (10%)	(1~99)	RTN signal transmission condition (1)
03:	15 (15 lines)	(2~99)	RTN signal transmission condition (2)
04:	12 (12 times)	(1~99)	RTN signal transmission condition (3)
05:	4		Pause time for NCC (before the ID code)
06:	4		Pause time for NCC (after the ID code)
07:	350 (3500 ms)	(0~9999)	Prepause time for outgoing calls
08:	0		Not used
09:	6 (6 digits)	(1~20)	The number of digits in telephone number compared against TSI signal to be matched for restricted receiving function
10:	5500 (55 seconds)	(0~9999)	Line connection detection time (T0 timer)
11:	3500 (35 seconds)	(0~9999)	T1 timer (Rx)
12:	0		Not used
13:	1310 (13.1 seconds)	(0~9999)	Maximum time to receive oneline of image data
14:	0		Not used
15:	120 (1200 ms)	(0~999)	Not used
16:	4 (4 seconds)	(0~9)	Hooking detection time
17:	100 (1000 ms)	(0~999)	Pseudo RBT transmission from CML on time until start
18:	0 (0 ms)	(0~999)	Pseudo RBT signal pattern: On time
19:	400 (4000 ms)	(0~999)	Pseudo RBT signal pattern: Off time (short)
20:	100 (1000 ms)	(0~999)	Pseudo RBT signal pattern: Off time (long)
21:	0 (0ms)	(0~999)	Pseudo ring pattern: On time setting
22:	400 (4000 ms)	(0~999)	Pseudo ring pattern: Off time (short)
23:	44		Pseudo ring pattern: Off time (long)
24:	10	(0~20)	Not used
25:	60 (600 s)	(0~999)	Pseudo-RBT signal transmission level
26:	44		Answering machine connection function signal detection level
27:	0		Not used
28:	0		Not used
29:	0		Not used
30:	0		Not used

Figure 3-12 Service Data (page 3)



No. 01, 08, 12, 14, 23, and 26 to 30 are not used. Do not change their settings.



NOTE

#3 NUMERIC PARAM. (Numeric parameter settings)

The relationship between the settings and the detection levels is as follows:

Parameter 24

0: Not used	1: Not used	2: Not used	3: Not used	4: Not used
5: 0 dBm	6: -1 dBm	7: -2 dBm	8: -3 dBm	9: -4 dBm
10: -5 dBm	11: -6 dBm	12: -7 dBm	13: -8 dBm	14: -9 dBm
15: -10 dBm	16: -11 dBm	17: -12 dBm	18: -13 dBm	19: -14 dBm
20: -15 dBm				

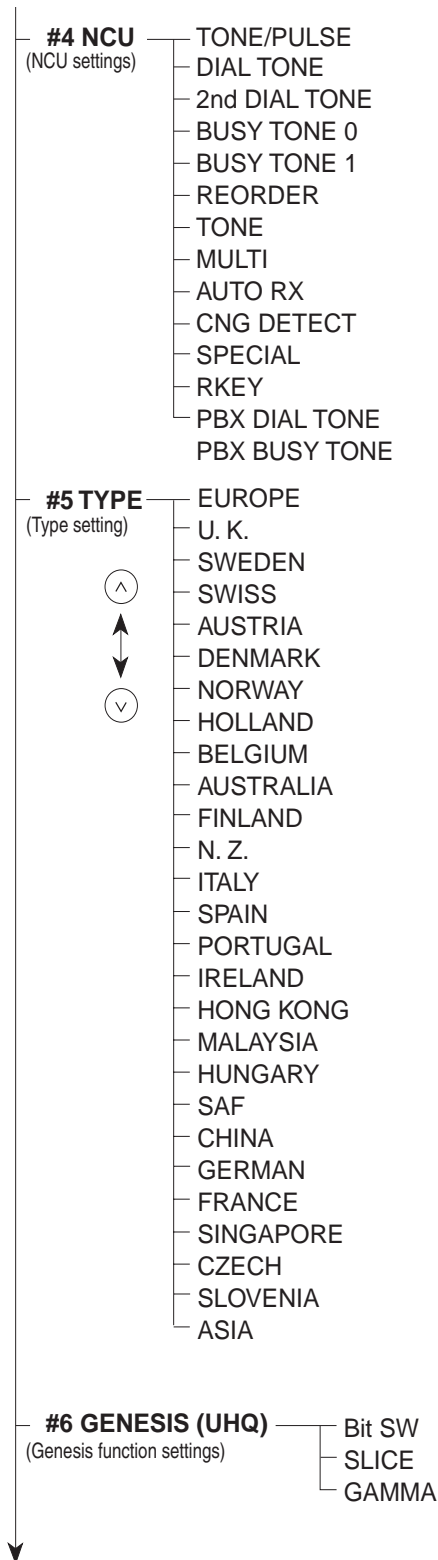

Figure 3-13 Service Data (page 4)



#4 NCU (NCU settings)

The values of these items are all set to match a specific nation's communications standards by the #5 TYPE setting.

#6 GENESIS (UHQ function settings)

Tampering with this setting may cause the scanned image quality to deteriorate. Do not change these settings.

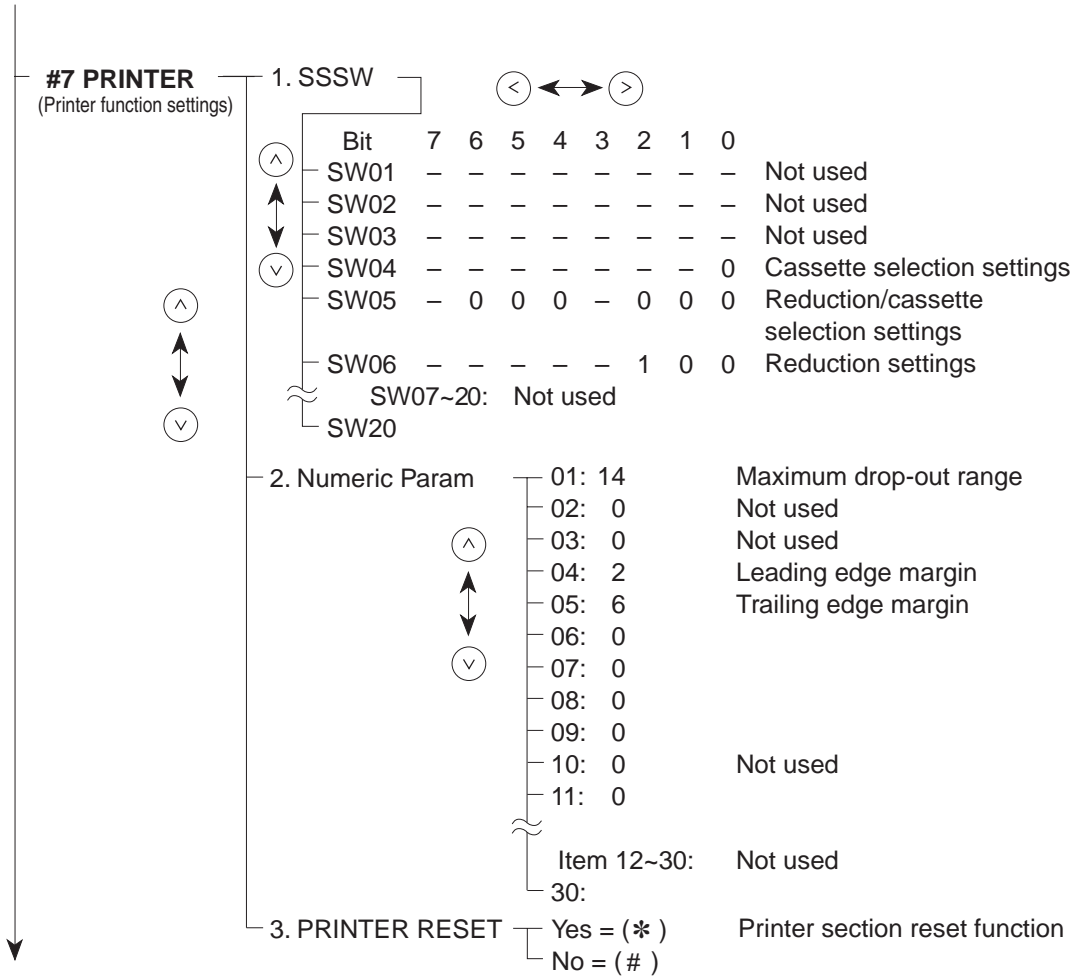

Figure 3-14 Service Data (page 5)

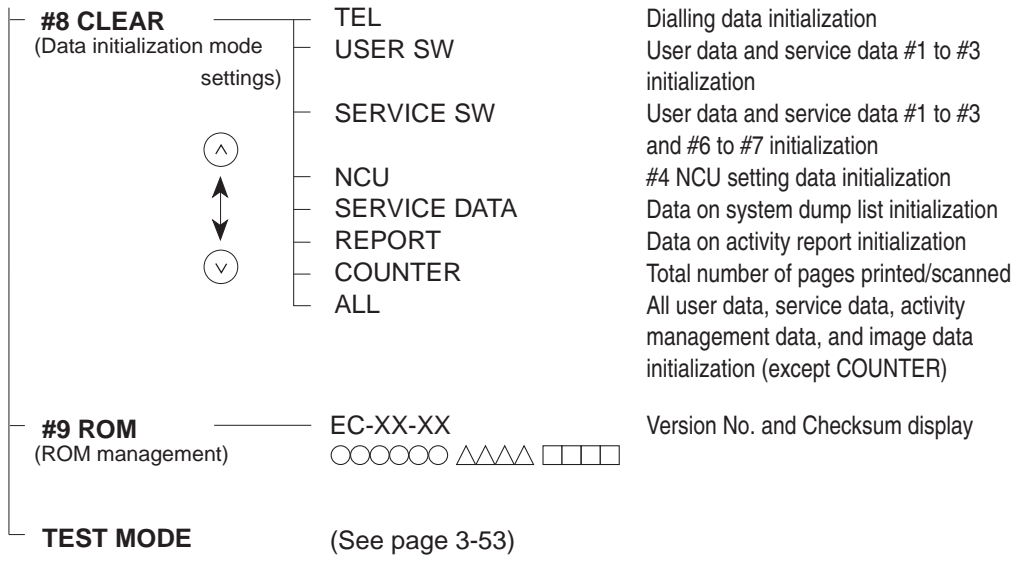

Figure 3-15 Service Data (page 6)



REFERENCE

For details on test mode, see *6.1 Service Test Functions on page 3-53*.

5.2.4 Explanation of service data

a) SSSW (Service Soft Switch settings)

The items registered and set by each of these switches comprise 8-bit switches. The figure below shows which numbers are assigned to which bits. Each bit has a value of either 0 or 1.

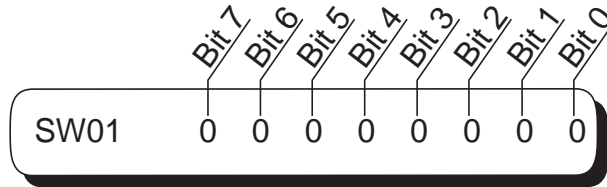

Figure 3-16 Bit Switch Display

See the chart in the service data shown in *this Chapter, 5.2.3 Service data settings* to see effective bits and their default values. With the exception of new switches added to this model the meanings (functions) of the bits are not described in this manual except the new switches added to this model. See *the G3 Facsimile Service Data Handbook* (supplied separately) for details of the switches.

Below are examples showing how to read bit switch tables.

Bit	Function	1	0
0	Service error code	Output	Not Output
1	Error dump list	Output	Not Output
2	Not used		
3	Copy function	No	Yes
4	##300 series service error code	Output	Not Output
5	Not used		
6	Date & Time setting restriction	Setting possible	Setting restricted
7	User setting restriction	Setting possible	Setting restricted

Indicates that the setting is "1".

Indicates that the setting is "0".

Figures in boldface are default settings.

Figure 3-17 How to Read Bit Switch Tables

5.2.5 New SSSWs/parameters added to this model

#1 SSSW (service soft switch setting)

SW01 (service soft switch 01: error management)

Bit	Function	1	0
0	Service error code	Output	Not output
1	Error dump list	Output	Not output
2	Not used		
3	Copy function	No	Yes
4 (New)	##300 series service error code	Output	Not output
5	Not used		
6	Data & Time setting restriction	Setting possible	Setting restricted
7	User setting restriction	Setting possible	Setting restricted

[Bit 4]

Even when Bit0 is set to “**NOT OUTPUT**”, you can select whether or not to output ##300 series Service Error Codes, caused by hardware malfunction.

When “**OUTPUT**” is selected, ##300 series Service Error Codes are displayed and included in reports.

When “**NOT OUTPUT**” is selected, no Service Error Codes are displayed.

#1 SSSW (service soft switch setting)

SW05 (service soft switch 05: standard function <DIS signal> settings)

Bit	Function	1	0
0	Not used		
1	Not used		
2	Not used		
3	Send DIS signal bits 33 and over	No	Yes
4	Recording paper length availability A4 size declared in DIS signal		Arbitrary size
5 (New)	Declare LTR/LGL in DIS signal	No	Yes
6	Not used		
7	Not used		

[Bit 5]

Select whether to declare LTR or LGL in DIS signal when the LTR or LGL recording paper is used.

The recording paper is selected according to the setting of #7 printer SW04 bit 0.

#1 SSSW (service soft switch setting)

SW15 (service soft switch 15: Dial inn FAX/TEL switching function setting)

Bit	Function	1	0
0	Not used		
1	Not used		
2	Not used		
3	Not used		
4	Not used		
5	Not used		
6 (New)	Detect continuous signal at FAX/TEL switching	Yes	No
7	Not used		

[Bit 6]

You may enable or disable detection of ROT continuous signal for FAX/TEL switching.

Normally, only ROT intermittent signals are detected for FAX/TEL switching. If you need to detect both in view of exchange specifications, select “1” to enable detection.

#1 SSSW (service soft switch setting)

SW18 (service soft switch 18: communication trouble solutions settings (2))

Bit	Function	1	0
0 (New)	Detection of carrier disconnection between the DCS signal and the TCF signal	Detect	Do not detect
1 (New)	Waiting time for carrier disconnection between the DCS signal and the TCF signal	600 ms	300 ms
2	Not used		
3	Not used		
4	Not used		
5	Not used		
6	Not used		
7	Not used		

[Bit 0]

It is possible to select whether or not to detect carrier disconnection between the DCS signal and the TCF signal during reception.

If the receiving machine returns an FTT signal while the other machine (PC-FAX) is transmitting a TCF signal and a reception error occurs, set this bit to "1".

If an error still occurs, set #1 SSSW SW18 Bit to "1".

[Bit 1]

It is possible to select the detection time for carrier disconnection between the DCS signal and TCF signal during reception.

This bit is available for use when #1 SSSW SW18 Bit 0 is set to "1".

#1 SSSW (service soft switch setting)

SW22 (service soft switch 22: Field Requests/Troubleshooting Issues)

Bit	Function	1	0
0	Not used		
1	Not used		
2	Not used		
3 (New)	Prohibit manual polling	Yes	No
4	Not used		
5	Not used		
6	Not used		
7	Not used		

[Bit 3]

You may disable polling initiated by manual operation (off hook + start).

#1 SSSW (service soft switch setting)

SW26 (service soft switch 26: Transmission function settings)

Bit	Function	1	0
0	Compulsory direct transmission	Set	Not set
1	Not used		
2	Not used		
3 (New)	Prohibit broadcast	Yes	No
4	Not used		
5	Not used		
6	When STOP key is pressed during a sequential broadcasting	Only cancel communication	Cancel all communication
7	Error transmission report when transmission is stopped	Not output	Output

[Bit 3]

You may disable selection of multiple addresses to prevent broadcasting by mistake (on the part of the user); however, this setting will not affect broadcasting by group dialing.

#1 SSSW (service soft switch setting)

SW28 (service soft switch 28: V.8/V.34 protocol settings)

Bit	Function	1	0
0 (New)	Caller V.8 protocol	No	Yes
1 (New)	Called party V.8 protocol	No	Yes
2 (New)	Caller V.8 protocol late start	No	Yes
3 (New)	Called party V.8 protocol late start	No	Yes
4 (New)	V.34 reception fallback	Prohibited	Not prohibited
5 (New)	V.34 transmission fallback	Prohibited	Not prohibited
6	Not used		
7	Not used		

[Bit 0]

Select whether to use the V.8 protocol when calling. If No is selected, the V.8 protocol is inhibited at calling and the V.21 protocol is used.

[Bit 1]

Select whether to use the V.8 protocol when calling. If No is selected, the V.8 protocol is inhibited when called and the V.21 protocol is used.

[Bit 2]

If ANSam signal is not received during transmission, select whether to use the V.8 protocol when the other fax machine declares the V.8 protocol in DIS signal. If No is selected, the CI signal is not transmitted and the V.8 protocol is not used even if the DIS that specifies the V.8 protocol is received. The V.8 late start is not executed during manual transmission regardless of this setting.

[Bit 3]

Select whether to declare the V.8 protocol in DIS signal for reception. If No is selected, the V.8 protocol cannot be used because it is not declared in DIS signal. The V.8 late start is not executed during manual reception regardless of this setting.

[Bit 4]

Select whether the receiver falls back V.34 reception. If Prohibited is selected, the receiver does not fall back.

[Bit 5]

Select whether the transmitter falls back V.34 transmission. If Prohibited is selected, the transmitter does not fallback.

#2 MENU

No.	Function	Selecting range	Default setting
08	V.34 max. baud rate	2400 ~ 3429	3429 (3429 baud)
09	V.34 max. transmission speed	24 ~ 33.6	33.6 (33600 bps)

[No. 08]

Select the maximum baud rate for V.34 transmission: 3429, 3200, 3000, 2800, 2743, and 2400.

[No. 09]

Select the maximum transmission speed for V.34 transmission: 2400 to 33600 bps.
(2400 × n: 1 ≤ n ≤ 14).



This model cannot use 2800 baud due to its modem specification. If it is set to 2800 baud, the maximum baud rate is 2743 baud.

NOTE

#3 NUMERIC PARAM. (numeric parameter settings)

No.	Function	Selecting range	Default setting
07	Prepause time for outgoing calls	0-9999	350 (3500 ms)
10	T0 Timer	0-9999	5500 (55 second)
11	T1 Timer (Rx)	0-9999	3500 (35 second)
13	Maximum time to receive one line of image data	500-3000	1300 (13 second)

[No. 7]

When an automatic outgoing call is made, it is possible to set the time from when the circuit is closed until the outgoing call is made.

Adjust this parameter if an external outgoing call cannot be made via the private branch exchange.

[No. 10]

The "wait time after transmission of a dialing signal ends until a significant signal is detected in transmission" was formerly designated as T1 timer with parameter 10.

However, ITU-T recommends that it should be designated as T0 timer, so parameter 10 has been renamed to T0 timer and the default time-out time has been changed from 35 to 55 seconds.



The T1 timer for the transmitter (wait time after a significant CED or V21 flag significant signal is detected until the next significant signal is detected) is fixed at 35 seconds.

NOTE

[No. 11]

Set the T1 timer for the receiver (wait time after DIS transmission starts until a significant signal is received.)

If frequent errors occur during reception (2 instances) because of line connection conditions, raise the value of this parameter.

[No. 13]

Set the maximum time to receive one line of image data when image data is received.

If the other party is a computer fax and the time to receive one line of image data is long, raise the value of this parameter to increase the maximum reception time.

#7 PRINTER

service soft switch setting

SW04 (switch 04: reduction/cassette selection settings)

Bit	Function	1	0
0 (New)	When LTR/LGL specification is received by DCS, the cassette is selected according to the specification	No	Yes
1	Not used		
2	Not used		
3	Not used		
4	Not used		
5	Not used		
6	Not used		
7	Not used		

[Bit 0]

Selects whether or not the recording paper is selected according to the DCS specification when the other fax machine specifies LTR or LGL in DCS signal during reception. If it is 0, the specified recording paper is used regardless of the paper length. If it is 1, the receiving station selects the recording paper. This switch is valid when #1 SW05 bit 5 is 0.

SSSW Default Setting

TYPE	EUROPE	U.K.	SWEDEN	SWISS	AUSTRIA	DENMARK
#1 SSSW						
SW01	00010000	00010000	00010000	00010000	00010000	00010000
SW02	00000000	00000000	00000000	00000000	00000000	00000000
SW03	00000000	00000000	00000000	00000000	00000000	00000000
SW04	10000000	10000000	10000010	10000010	10000010	10000000
SW05	00000000	00000000	00000000	00000000	00000000	00000000
SW06	10000000	10000000	10000000	10000000	10000000	10000000
SW07	00000000	00000000	00000000	00000000	00000000	00000000
SW08	00000000	00000000	00000000	00000000	00000000	00000000
SW09	00000000	00000000	00000000	00000000	00000000	00000000
SW10	00000000	00000000	00000000	00000000	00000000	00000000
SW11	00000000	00000000	00000000	00000000	00000000	00000000
SW12	00000010	00000010	00000010	00000010	00000010	00000010
SW13	00000000	00000000	00000000	00000000	00000000	00000000
SW14	00000000	00000000	00000000	00000000	00000000	00000000
SW15	00000000	01000000	00000000	00000000	00000000	00000000
SW16	00000011	00000011	00000011	00000011	00000011	00000011
SW17	00000000	00000000	00000000	00000000	00000000	00000000
SW18	00000000	00000000	00000000	00000000	00000000	00000000
SW19	00000000	00000000	00000000	00000000	00000000	00000000
SW20	00000000	00000000	00000000	00000000	00000000	00000000
SW21	00000000	00000000	00000000	00000000	00000000	00000000
SW22	00000000	00000000	00000000	00000000	00000000	00000000
SW23	00000000	00000000	00000000	00000000	00000000	00000000
SW24	00000000	00000000	00000000	00000000	00000000	00000000
SW25	00000000	00000000	00000000	00000000	00000001	00000000
SW26	00000000	00000000	00000000	00000000	00000000	00000000
SW27	00000000	00000000	00000000	00000000	00000000	00000000
SW28	00000000	00000000	00000000	00000000	00000000	00000000
SW29	00000000	00000000	00000000	00000000	00000000	00000000
SW30	00000000	00000000	00000000	00000000	00000000	00000000
#2 MENU						
05:	OFF	OFF	OFF	OFF	OFF	OFF
06:	DIAL	DIAL	DIAL	DIAL	DIAL	DIAL
07:	10	10	10	10	10	10
08:	3429	3429	3429	3429	3429	3429
09:	33.6	33.6	33.6	33.6	33.6	33.6
10:	25Hz	25Hz	25Hz	25Hz	25Hz	25Hz

SSSW Default Setting

TYPE	NORWAY	HOLLAND	BELGIUM	AUSTRALIA	FINLAND	N.Z.
#1 SSSW						
SW01	00010000	00010000	00010000	00010000	00010001	00010000
SW02	00000000	00000000	00000000	00000000	00000000	00000000
SW03	00000000	00000000	00000000	00000000	00000000	00000000
SW04	10000010	10000010	10000000	10000000	10000000	10000000
SW05	00000000	00000000	00000000	00000000	00000000	00000000
SW06	10000000	10000000	10000000	10000000	10000000	10000000
SW07	00000000	00000000	00000000	00000000	00000000	00000000
SW08	00000000	00000000	00000000	00000000	00000000	00000000
SW09	00000000	00000000	00000000	00000000	00000000	00000000
SW10	00000000	00000000	00000000	00000000	00000000	00000000
SW11	00000000	00000000	00000000	00000000	00000000	00000000
SW12	00000010	00000010	00000010	00000010	00000010	00000010
SW13	00000000	00000000	00000000	00000000	00000000	00000000
SW14	00000000	00000000	00000000	00000000	00000000	00000000
SW15	00000000	00000000	00000000	00000000	00000000	00000000
SW16	00000011	00000011	00000011	00000011	00000011	00000011
SW17	00000000	00000000	00000000	00000000	00000000	00000000
SW18	00000000	00000000	00000000	00000000	00000000	00000000
SW19	00000000	00000000	00000000	00000000	00000000	00000000
SW20	00000000	00000000	00000000	00000000	00000000	00000000
SW21	00000000	00000000	00000000	00000000	00000000	00000000
SW22	00000000	00000000	00000000	00000000	00000000	00000000
SW23	00000000	00000000	00000000	00000000	00000000	00000000
SW24	00000000	00000000	00000000	00000000	00000000	00000000
SW25	00000000	00000000	00000000	00000000	00000000	00000000
SW26	00000000	00000000	00000000	00000000	00000000	00000000
SW27	00000000	00000000	00000000	00000000	00000000	00000000
SW28	00000000	00000000	00000000	00000000	00000000	00000000
SW29	00000000	00000000	00000000	00000000	00000000	00000000
SW30	00000000	00000000	00000000	00000000	00000000	00000000
#2 MENU						
05:	OFF	OFF	OFF	OFF	OFF	OFF
06:	DIAL	DIAL	DIAL	DIAL	DIAL	DIAL
07:	10	10	10	12	10	13
08:	3429	3429	3429	3429	3429	3429
09:	33.6	33.6	33.6	33.6	33.6	33.6
10:	25Hz	25Hz	25Hz	25Hz	25Hz	25Hz

SSSW Default Setting

TYPE	ITALY	SPAIN	PORTUGAL	IRELAND	HONG KONG	MALAYSIA
#1 SSSW						
SW01	00010000	00010000	00010000	00010000	00010000	00010000
SW02	00000000	00000000	00000000	00000000	00000000	00000000
SW03	00000000	00000000	00000000	00000000	00000000	00000000
SW04	10000010	10000010	10000010	10000000	10000000	10000000
SW05	00000000	00000000	00000000	00000000	00000000	00000000
SW06	10000000	10000000	10000000	10000000	10000000	10000000
SW07	00000000	00000000	00000000	00000000	00000000	00000000
SW08	00000000	00000000	00000000	00000000	00000000	00000000
SW09	00000000	00000000	00000000	00000000	00000000	00000000
SW10	00000000	00000000	00000000	00000000	00000000	00000000
SW11	00000000	00000000	00000000	00000000	00000000	00000000
SW12	00000010	00000010	00000010	00000010	00000010	00000010
SW13	00000000	00000000	00000000	00000000	00000000	00000000
SW14	00000000	00000000	00000000	00000000	00000000	00000000
SW15	00000000	00000000	00000000	00000000	00000000	00000000
SW16	00000011	00000011	00000011	00000011	00000011	00000011
SW17	00000010	00000000	00000000	00000000	00000000	00000000
SW18	00000000	00000000	00000000	00000000	00000000	00000000
SW19	00000000	00000000	00000000	00000000	00000000	00000000
SW20	00000000	00000000	00000000	00000000	00000000	00000000
SW21	00000000	00000000	00000000	00000000	00000000	00000000
SW22	00000000	00000000	00000000	00000000	00000000	00000000
SW23	00000000	00000000	00000000	00000000	00000000	00000000
SW24	00000000	00000000	00000000	00000000	00000000	00000000
SW25	00000000	00000001	00000000	00000000	00000000	00000000
SW26	10000000	00000000	00000000	00000000	00000000	00000000
SW27	00000000	00000000	00000000	00000000	00000000	00000000
SW28	00000000	00000000	00000000	00000000	00000000	00000000
SW29	00000000	00000000	00000000	00000000	00000000	00000000
SW30	00000000	00000000	00000000	00000000	00000000	00000000
#2 MENU						
05:	OFF	OFF	OFF	OFF	OFF	OFF
06:	DIAL	DIAL	DIAL	DIAL	DIAL	DIAL
07:	10	10	10	10	10	10
08:	3429	3429	3429	3429	3429	3429
09:	33.6	33.6	33.6	33.6	33.6	33.6
10:	25Hz	25Hz	25Hz	25Hz	25Hz	25Hz

SSSW Default Setting

TYPE	HUNGARY	SAF	CHINA	GERMAN	SINGAPORE	CZECH
#1 SSSW						
SW01	00010000	00010000	00010000	00010000	00010000	00010000
SW02	00000000	00000000	00000000	00000000	00000000	00000000
SW03	00000000	00000000	00000000	00000000	00000000	00000000
SW04	10000000	10000000	10000000	00000010	10000000	10000000
SW05	00000000	00000000	00000000	00000000	00000000	00000000
SW06	10000000	10000000	10000000	10000000	10000000	10000000
SW07	00000000	00000000	00000000	00000000	00000000	00000000
SW08	00000000	00000000	00000000	00000000	00000000	00000000
SW09	00000000	00000000	00000000	00000000	00000000	00000000
SW10	00000000	00000000	00000000	00000000	00000000	00000000
SW11	00000000	00000000	00000000	00000000	00000000	00000000
SW12	00000010	00000010	00000010	00000010	00000010	00000010
SW13	00000000	00000000	00000000	00000000	00000000	00000000
SW14	00000000	00000000	00000000	00000000	00000000	00000000
SW15	00000000	00000000	00000000	00000000	00000000	00000000
SW16	00000011	00000011	00000011	00000011	00000011	00000011
SW17	00000000	00000000	00000000	00000000	00000000	00000000
SW18	00000000	00000000	00000000	00000000	00000000	00000000
SW19	00000000	00000000	00000000	00000000	00000000	00000000
SW20	00000000	00000000	00000000	00000000	00000000	00000000
SW21	00000000	00000000	00000000	00000000	00000000	00000000
SW22	00000000	00000000	00000000	00001000	00000000	00000000
SW23	00000000	00000000	00000000	00000000	00000000	00000000
SW24	00000000	00000000	00000000	00000000	00000000	00000000
SW25	00000000	00000000	00000000	00000001	00000000	00000000
SW26	00000000	00000000	00000000	00000000	00000000	00000000
SW27	00000000	00000000	00000000	00000000	00000000	00000000
SW28	00000000	00000000	00000000	00000000	00000000	00000000
SW29	00000000	00000000	00000000	00000000	00000000	00000000
SW30	00000000	00000000	00000000	00000000	00000000	00000000
#2 MENU						
05:	OFF	OFF	OFF	OFF	OFF	OFF
06:	DIAL	DIAL	DIAL	DIAL	DIAL	DIAL
07:	10	10	13	10	10	10
08:	3429	3429	3429	3429	3429	3429
09:	33.6	33.6	33.6	33.6	33.6	33.6
10:	25Hz	25Hz	25Hz	25Hz	25Hz	25Hz

SSSW Default Setting

TYPE	SLOVENIA	FRANCE	ASIA
#1 SSSW			
SW01	00010000	00010000	00010000
SW02	00000000	00000000	00000000
SW03	00000000	00000000	00000000
SW04	10000000	00000010	10000000
SW05	00000000	00000000	00000000
SW06	10000000	10000000	10000000
SW07	00000000	00000000	00000000
SW08	00000000	00000000	00000000
SW09	00000000	00000000	00000000
SW10	00000000	00000000	00000000
SW11	00000000	00000000	00000000
SW12	00000010	00000010	00000010
SW13	00000000	00000000	00000000
SW14	00000000	00000000	00000000
SW15	00000000	00000000	00000000
SW16	00000011	00000011	00000011
SW17	00000000	00000000	00000000
SW18	00000000	00000000	00000000
SW19	00000000	00000000	00000000
SW20	00000000	00000000	00000000
SW21	00000000	00000000	00000000
SW22	00000000	00000000	00000000
SW23	00000000	00000000	00000000
SW24	00000000	00000000	00000000
SW25	00000000	00000001	00000000
SW26	00000000	00000000	00000000
SW27	00000000	00000000	00000000
SW28	00000000	00000000	00000000
SW29	00000000	00000000	00000000
SW30	00000000	00000000	00000000
#2 MENU			
05:	OFF	OFF	OFF
06:	DIAL	DIAL	DIAL
07:	10	10	10
08:	3429	3429	3429
09:	33.6	33.6	33.6
10:	25Hz	25Hz	25Hz

SSSW Default Setting

TYPE	EUROPE	U.K.	SWEDEN	SWISS	AUSTRIA	DENMARK
#3 NUMERIC Param						
02:	10	10	10	10	10	10
03:	15	15	15	15	15	15
04:	12	12	12	12	12	12
05:	4	4	4	4	4	4
06:	4	1	4	4	4	4
07:	350	350	350	350	350	350
09:	6	6	6	6	6	6
10:	5500	5500	5500	5500	5500	5500
11:	3500	3500	3500	3500	3500	3500
13:	1310	1310	1310	1310	1310	1310
15:	120	120	120	120	120	120
16:	4	4	4	4	4	4
17:	100	100	100	40	100	75
18:	0	0	0	20	0	0
19:	400	400	400	200	400	250
20:	100	100	100	100	100	100
21:	0	0	0	0	0	0
22:	400	400	400	400	400	400
23:	44	44	44	44	44	44
24:	10	10	10	10	10	10
25:	60	60	60	60	60	60
26:	44	44	44	44	44	44
#5 TYPE	EUROPE	U.K.	SWEDEN	SWISS	AUSTRIA	DENMARK

SSSW Default Setting

TYPE	NORWAY	HOLLAND	BELGIUM	AUSTRALIA	FINLAND	N.Z.
#3 NUMERIC Param						
02:	10	10	10	10	10	10
03:	15	15	15	15	15	15
04:	12	12	12	12	12	12
05:	4	4	4	4	4	4
06:	4	4	4	4	4	4
07:	350	350	350	350	350	350
09:	6	6	6	6	6	6
10:	5500	5500	5500	5500	5500	5500
11:	3500	3500	3500	3500	3500	3500
13:	1310	1310	1310	1310	1310	1310
15:	120	120	120	120	120	120
16:	4	4	4	4	3	2
17:	30	100	100	100	100	100
18:	30	0	0	0	0	0
19:	400	400	300	400	400	400
20:	30	100	100	100	100	100
21:	30	0	0	0	0	0
22:	400	400	300	400	400	400
23:	44	44	44	44	44	44
24:	10	10	10	10	12	10
25:	60	60	60	60	60	60
26:	44	44	44	44	44	44
#5 TYPE	NORWAY	HOLLAND	BELGIUM	AUSTRALIA	FINLAND	N.Z.

SSSW Default Setting

TYPE	ITALY	SPAIN	PORTUGAL	IRELAND	HONG KONG	MALAYSIA
#3 NUMERIC Param						
02:	10	10	10	10	10	10
03:	15	15	15	15	15	15
04:	12	12	12	12	12	12
05:	4	15	4	4	4	4
06:	4	3	4	4	1	4
07:	350	350	350	350	350	350
09:	6	6	6	6	6	6
10:	5500	5500	5500	5500	5500	5500
11:	3500	3500	3500	3500	3500	3500
13:	1310	1310	1310	1310	1310	1310
15:	120	120	120	120	120	120
16:	4	4	4	4	4	4
17:	100	100	100	100	40	100
18:	0	0	0	0	20	0
19:	400	400	400	400	200	400
20:	100	100	100	100	40	100
21:	0	0	0	0	20	0
22:	400	400	400	400	200	400
23:	44	44	44	44	44	44
24:	10	10	10	10	10	10
25:	60	60	60	60	60	60
26:	44	44	44	44	44	44
#5 TYPE	ITALY	SPAIN	PORTUGAL	IRELAND	HONG KONG	MALAYSIA

SSSW Default Setting

TYPE	HUNGARY	SAF	CHINA	GERMAN	SINGAPORE	CZECH
#3 NUMERIC Param						
02:	10	10	10	8	10	10
03:	15	15	15	15	15	15
04:	12	12	12	6	12	12
05:	4	4	4	4	4	4
06:	4	4	4	4	4	4
07:	350	350	350	350	350	350
09:	6	6	6	6	6	6
10:	5500	3500	4300	9000	5500	5500
11:	3500	3500	3500	3500	3500	3500
13:	1310	1310	1200	1310	1310	1310
15:	120	120	120	120	120	120
16:	4	4	4	4	4	4
17:	100	100	100	100	100	100
18:	0	0	0	0	0	0
19:	400	400	400	400	400	400
20:	100	100	100	100	100	100
21:	0	0	0	0	0	0
22:	400	400	400	400	400	400
23:	44	44	44	44	44	44
24:	10	10	10	10	10	10
25:	60	60	60	60	60	60
26:	44	44	44	44	44	44
#5 TYPE	HUNGARY	SAF	CHINA	GERMAN	SINGAPORE	CZECH

TYPE	SLOVENIA	FRANCE	ASIA
#3 NUMERIC Param			
02:	10	8	10
03:	15	15	15
04:	12	12	12
05:	4	4	4
06:	4	4	4
07:	350	350	350
09:	6	6	6
10:	5500	5500	5500
11:	3500	3800	3500
13:	1310	1310	1310
15:	120	120	120
16:	4	4	4
17:	100	30	100
18:	0	30	0
19:	400	400	400
20:	100	150	100
21:	0	0	0
22:	400	300	400
23:	44	44	44
24:	10	10	10
25:	60	60	60
26:	44	44	44
#5 TYPE	SLOVENIA	FRANCE	ASIA

6. TEST FUNCTIONS

6.1 Service Test Functions

The fax functions for testing individual operations, such as below.

See *Page 3-36* for details of entering the test mode. To leave the test mode, press the *CLEAR* button.

6.1.1 Test mode overview

Test mode can be executed by following the menu items from the display.

a) DRAM tests

Writes data to DRAM image storage areas and reads that data to check operations.

b) Print test

Prints nine different patterns within the print area.

c) Modem, NCU tests

These tests comprise the frequency test ,the G3 signal transmission test, and the CNG and DTMF signals reception test, and V.34 G3 signal transmission test.

d) Faculty tests

These test check the operation of operation panel and sensor functions.

6.1.2 Test mode flowchart

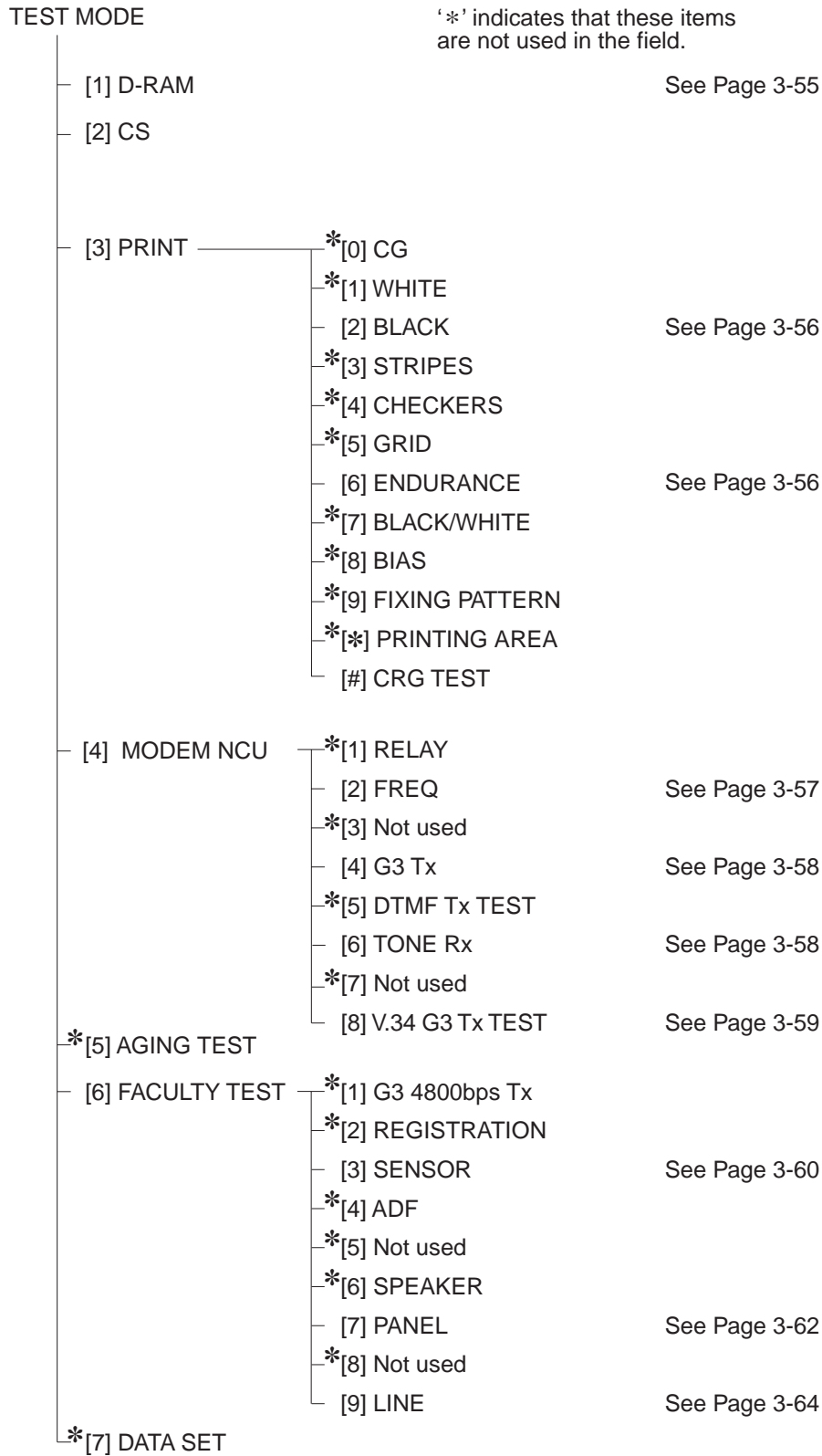

Figure 3-18 Test Mode

6.1.3 D-RAM tests

Pressing the 1 button from the test mode menu selects the D-RAM tests. D-RAM Test 1 writes data to the entire D-RAM region and reads it out to check that operations are correct. D-RAM Test 2 just reads data at high speed.

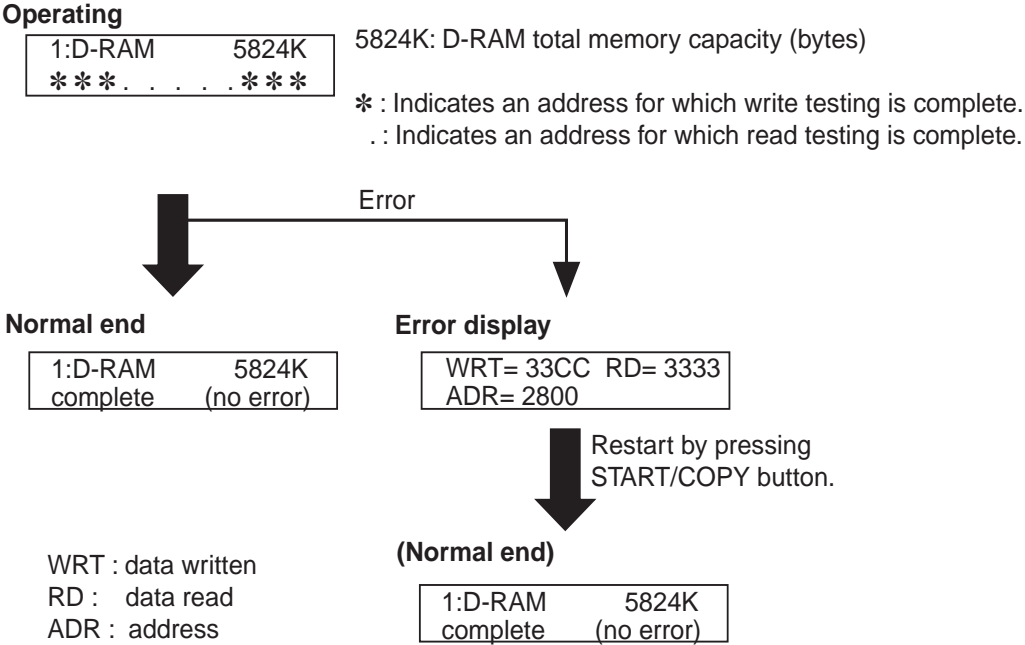

Figure 3-19 D-RAM Test

6.1.4 Print

The Print Test menu is selected by pressing the 3 key from the test mode menu. In this test, various print patterns are output from the printer. As service print patterns, press *numeric* button 2 from the Print Test menu to select “**3-2: Black**” or press numeric button 6 to select “**3-6: Endurance**”. Do not use the other patterns. They are for development and factory use.

Check the following for the print pattern.

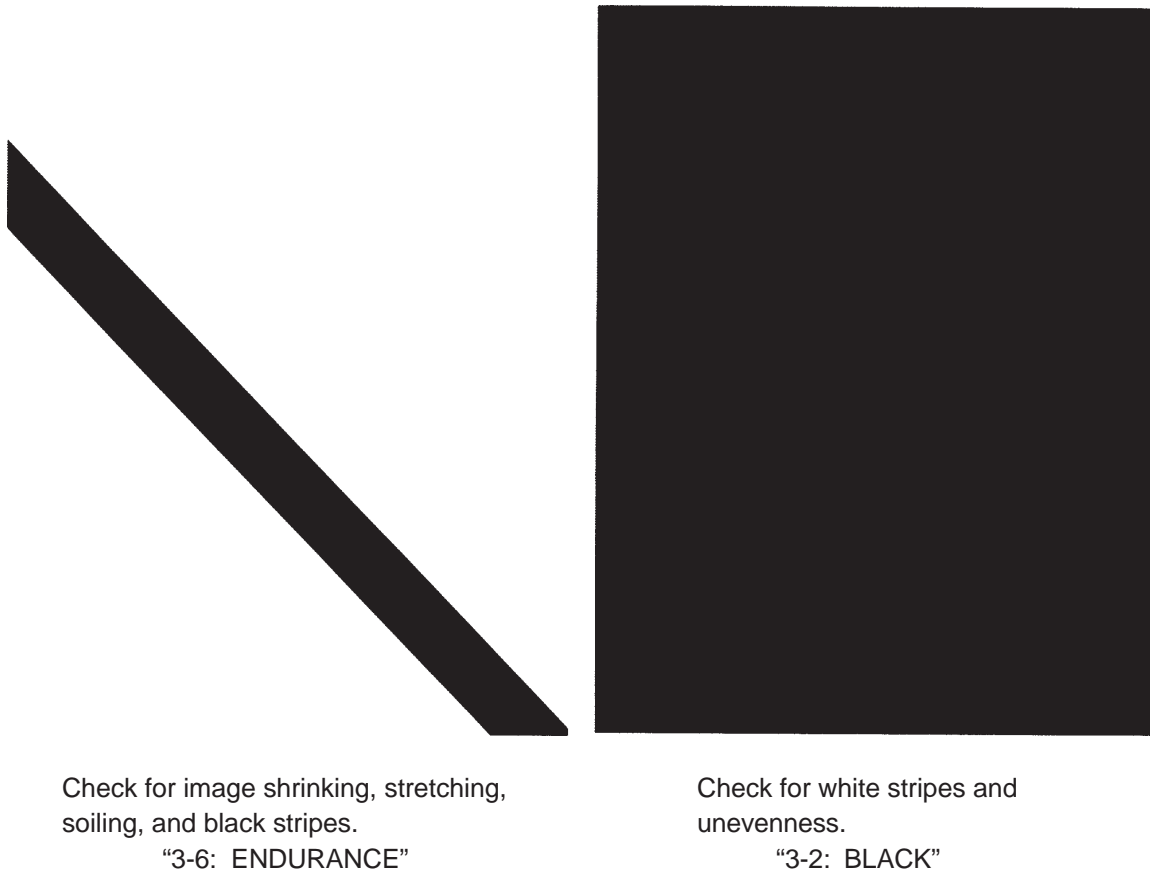
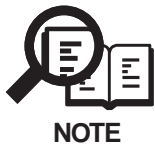

Figure 3-20 Print Pattern Check



After completion of the print test, if the printing was normal, copy a document. If there is any defect in the copied image, there is a defect in the scan section.

NOTE

6.1.5 Modem and NCU tests

These tests test modem and NCU transmission and reception. The modem tests check whether signals are sent correctly from the modem by comparing the sound of the signals from the speaker with the sounds from a normal modem. Also, on the display indicates whether or not the modem correctly detected received tone signals and DTMF signals.

End this test by pressing the *STOP* button.

Modem test type	Overview
Frequency test	The modem sends tone signals from the modular jack and the speaker.
G3 signal transmission test	The modem sends G3 signals from the modular jack and the speaker.
Tonal signal reception tests	The modem detects specific frequencies and DTMF signals received from the modular jack.
V.34 G3 signal transmission test	The modem sends V.34 G3 signals from the modular jack and the speaker.

a) Frequency test

The frequency test menu is selected by pressing numeric button 2 from the MODEM NCU test menu. Signals of the frequencies below are sent from the modem using the modular jack and the speaker. The frequency can be changed with the numeric buttons.

Numeric button	Frequency
1	462 Hz
2	1100 Hz
3	1300 Hz
4	1500 Hz
5	1650 Hz
6	1850 Hz
7	2100 Hz



NOTE

The pseudo-ringback tone transmission pattern and frequency and the output levels for each frequency follow the service data transmission level settings.

b) G3 signal transmission test

The G3 signal transmission test menu is selected by pressing numeric button 4 from the MODEM NCU test menu. The G3 signals below are sent from the modem using the modular jack and the speaker. The frequency can be changed with the numeric buttons.

Numeric button	Frequency
0	300 bps
1	2400 bps
2	4800 bps
3	7200 bps
4	9600 bps
5	TC7200 bps
6	TC9600 bps
7	12000 bps
8	14400 bps



The transmission level can be changed with the *FUNCTION* button then < and > button.

NOTE

c) Tonal and DTMF signal reception test

The tonal and DTMF signal reception test is selected by pressing the 6 button from the MODEM NCU test menu. This test checks whether the tonal signals and DTMF signals received from the modular jack are detected by the modem.

Tonal signal reception test

```
4 - 6 : TONE Rx      0 0 0
```

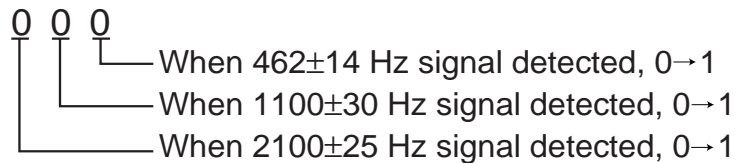

DTMF signal reception test

```
4 - 6 : TONE Rx      0 0 0
                    1 2 3 4 5 6 7 8 9 0
```

The received DTMF signals are displayed in order from the right on the second line of the display.

Figure 3-21 Tonal and DTMF Signal Reception Test

d) V.34 G3 signal transmission test

The V.34 G3 signal transmission test menu is selected by pressing numeric button 8 from the MODEM NCU test menu. The V.34 G3 signals below are sent from the modem using the modular jack and the speaker by pressing the start key. The baud rate can be changed with the numeric button, and the Speed can be changed with the search button.

Numeric button	Baud rate
0	3429 baud
1	3200 baud
2	3000 baud
3	2800 baud
4	2743 baud
5	2400 baud

Search button	Speed
	2400 bps
	4800 bps
^	7200 bps
	9600 bps
	12000 bps
	14400 bps
	16800 bps
	19200 bps
	21600 bps
	24000 bps
∨	26400 bps
	28800 bps
	31200 bps
	33600 bps



NOTE

The transition level for each frequency follows the service data.

6.1.6 Faculty tests

The faculty tests are selected by pressing numeric button 6 from the test mode menu. These tests check the following faculties of this fax.

Test type	Overview
Sensor tests	Test whether the sensors are operating correctly.
Operation panel test	Tests whether the button switches on the control panel are operating correctly.
Line signal reception test	Tests whether the NCU board signal sensor and frequency counter are operating correctly.

a) Sensor tests

The sensor test is selected by pressing numeric button 3 from the faculty test menu. This test checks the status of each sensor of this fax in item 1 on the display.

Sensors that use actuators and microswitches can be checked by moving the actuator or microswitch.

6-3 : SENSOR
[1] --- [5]

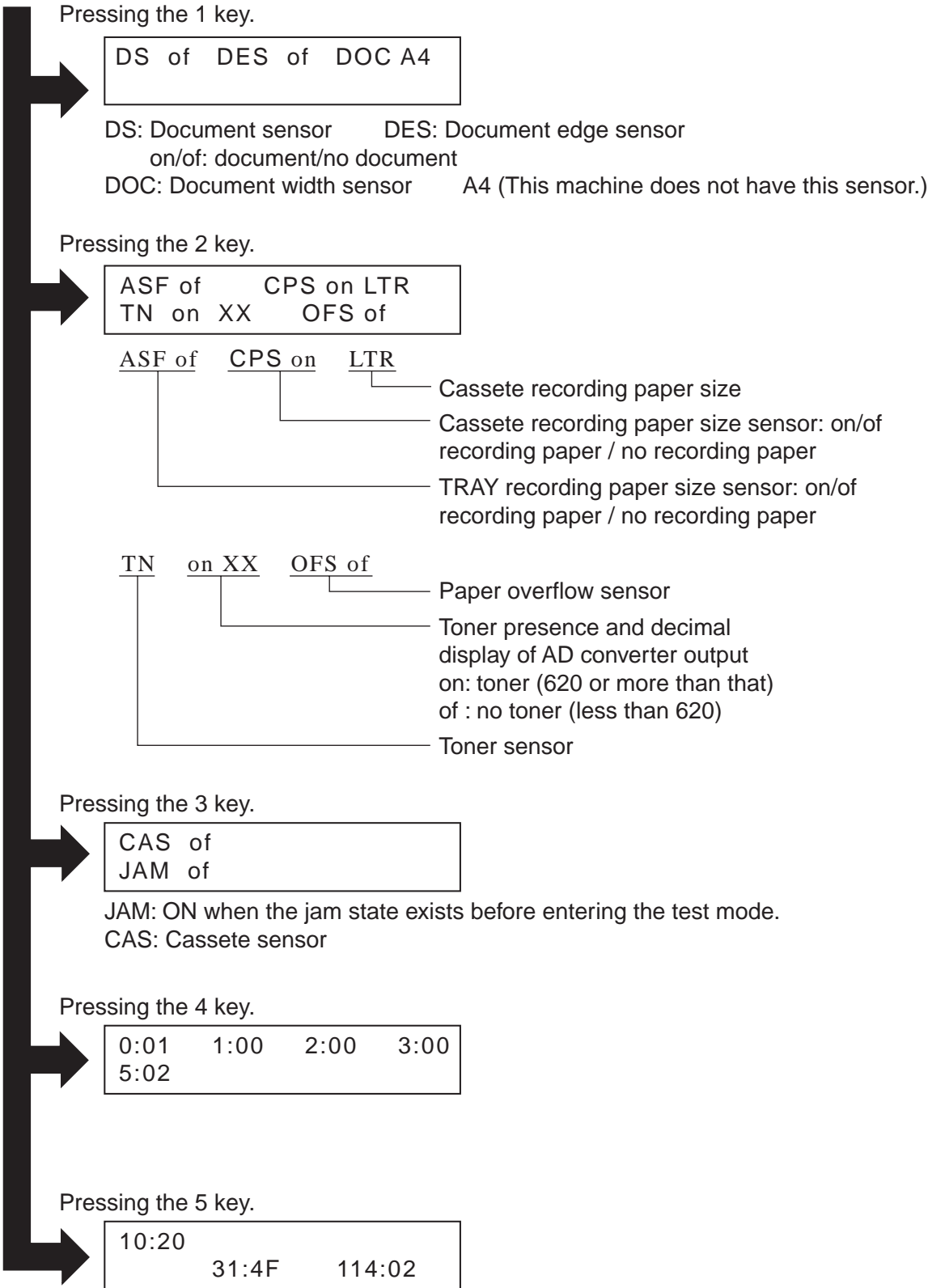

Figure 3-22 Sensor Tests

b) Operation panel tests

The operation panel test is selected by pressing numeric button 7 from the faculty test menu. This test checks that the display, LED lamps, and buttons on the control panel are operating correctly.

b-1) Display test

Pressing the *START/COPY* button from the control panel menu, "H" is displayed 20 characters by 2 line on the display. The next time the *START/COPY* button is pressed, all the LCD dots on the display are displayed. Check for any LCD dots in the display that are not displayed.

b-2) LED lamp test

The LED lamp test is selected by pressing the *START/COPY* button after the display test. When the *START/COPY* button is pressed, ALARM lamp, In Use/Memory lamp on the control panel light. Check for any LED that does not light during the test.

b-3) Operation button test

The Operation button test is selected by pressing the *START/COPY* button after the LED lamp test. In this test, you press the button corresponding to the displayed character to put it out. The table giving the correspondence between the characters and the buttons is below.

Character	Operation button	Character	Operation button
1-#	Numeric buttons	\$	Resolution button
P	R button	&	Receive mode button
R	Redial/Pause button	E	Set button
D	Coded dial/Directory button	O	Hook button

When all the characters displayed have gone out, the system next starts the one-touch speed dialing button test. The letters a-f are displayed on the display, corresponding to one-touch speed dialing buttons 01-32. Each letter displayed on the display goes out when its corresponding one-touch speed dialing button is pressed.

In this test, check for operation buttons whose corresponding character or letter does not go out when the button is pressed.

c) Line signal reception test

The line detect test menu is selected by pressing numeric button 9 from the faculty test menu. This test checks the operation of the NCU signal sensor and frequency counter. In Menu 1, the CI, status can be detected and in Menu 2 the frequency can be detected at changing detection levels. In this way, you can check if the NCU board is correctly detecting signals.

c-1) Test Menu 1

Test Menu 1 is selected by pressing numeric button 1 from the Line Detect menu. When CI, is detected from the modular jack, the display changes from OFF to ON and the received frequency is displayed.

c-2) Test Menu 2

Not used

c-3) Test Menu 3

Test Menu 3 is selected by pressing numeric button 3 from the Line Detect menu. When CNG is detected from the modular jack, the display changes from OFF to ON.

7. SERVICE REPORT

7.1 Report Output Function

7.1.1 User report output functions

The fax can output user reports manually, and some reports can be output automatically using the to user data settings.

a) Manual output of reports

Report type	Operations
Activity Report	After pressing the <i>Report</i> button, use the \wedge or \vee button to select ACTIVITY REPORT . After pressing the <i>Set</i> button.
User's Data List	After pressing the <i>Report</i> button, use the \wedge or \vee button to select USER DATA LIST . After pressing the <i>Set</i> button.
Speed Dialing Lists 1-touch dial list Coded speed dial list 1-touch (Detail) Coded (Detail) Group dial list	Press the <i>Report</i> button, then use the \wedge or \vee button to select SPEED DIAL LIST . After pressing the <i>Set</i> button, then use the N or M button to select List. After pressing the <i>Set</i> button.
Document Memory List	After pressing the <i>Report</i> button, then use the \wedge or \vee button to select DOC. MEMORY LIST . After pressing the <i>Set</i> button.

b) Reports which can be output automatically using user data and PC settings

Each report written below can be automatically output by specifying "REPORT SETTING" in user data.

Transmission report

Reception report



NOTE

ROM Version display

The ROM version is printed on the top left hand side of the User's data list. Please refer to this when troubleshooting.

example:

EC-XX-XX

MAIN ROM version

c) Reports output automatically

Memory clear list

The fax automatically outputs a memory clear list when the power is turned on after a power cut.

25/09/1999 09:39 FAX				001		
***** *** MEMORY CLEAR REPORT *** ***** MEMORY FILES DELETED						
TX/RX NO	MODE	CONNECTION TEL/ID	PGS.	SET TIME	ST. TIME	
0002	DELAYED TX	1234567890	1	09/25 17:34	08:00	
0003	B' CAST	[01]	1	09/25 17:46		
		[02]				

Figure 3-24 Memory Clear List

- TX/RX NO : Indicates four digits of the transaction number
- MODE : Indicates, **TRANSMISSION**, or **MEMORY RX**.
- CONNECTION TEL : Number sent from the other party or number dialled
- PAGES : Number of pages stored in memory
- SET TIME : Time when data was stored in memory
- START TIME : Planned transmission start time (24-hour display)

7.1.2 Service report output functions

The fax outputs current service data settings, and past communications history reports.

a) List of service reports

The fax outputs the service reports shown below.

Report type	Operations
1. Service & System list 2. System data list 3. System dump list	In the service mode, pressing the Report button, then use the \wedge or \vee button to select list.
Service activity report (with service error code and dump list)	If you set bits 0 and 1 of #1 SSSW SW01 in the service mode, the service error code and dump list are indicated on the activity report (sending/receiving).

a-1) System data list

This list shows the current settings service data #1~#5, #7 and #9.

The figure displays four overlapping screenshots of a fax machine's system data list, showing various parameters and their values. The screenshots are arranged in a descending staircase pattern from top-left to bottom-right.

Top-left screenshot (Page 1): Shows parameters SW11 through SW17 with values 00000000, 00000000, 00000000, 00000000, 00000000, 00110000, and 00000000 respectively. A page number '004' is visible in the top right.

Second screenshot (Page 2): Shows '5. BUSY TONE 1' with a value of 10000000. Below it are parameters 01 through 08 with values 500, 18, 60, 18, 60, 12, 3, and 3. A page number '003' is visible in the top right.

Third screenshot (Page 3): Shows parameters 11 through 22 with values 3500, 1320, 120, 4, 100, 0, 200, 100, 0, and 200. A page number '002' is visible in the top right.

Bottom-right screenshot (Page 4): Shows the title '*** SYSTEM DATA LIST ***' and three sections:

- #1 SSSW:** Lists parameters SW01 through SW30 with values ranging from 00000000 to 10010000.
- #2 MENU:** Lists parameters 05 through 10 with values OFF, DIAL, 10, 3429, 33.6, and 25Hz.
- #3 NUMERIC Param.:** Lists parameters 02 through 10 with values 10, 15, 12, 4, 4, 6, and 5500.

 A page number '001' is visible in the top right.

Figure 3-25 System Data List (page 1 ~ page 4)

25/09/1999 16:48 FAX		006
01 :	----	14
02 :	----	0
03 :	----	0

25/09/1999 16:48 FAX		005
41 :	----	0
42 :	----	0
43 :	----	0
44 :	----	0
45 :	----	0
46 :	----	0
47 :	----	10
48 :	----	50
49 :	----	0
50 :	----	0
11. RKEY		
01 :	----	0
02 :	----	0
03 :	----	0
12. PBX DIAL TONE		00000000
01 :	----	350
02 :	----	90
03 :	----	10
04 :	----	0
05 :	----	0
06 :	----	0
07 :	----	5
08 :	----	0
13. PBX BUSY TONE		00000000
01 :	----	1000
02 :	----	40
03 :	----	60
04 :	----	40
05 :	----	60
06 :	----	1
07 :	----	5
08 :	----	3

Figure 3-26 System Data List (page 5, page 6)



NOTE

“START DATE” records the date when the fax performs its first operation, after shipment from the factory.

CLEAR DATE : Date on which data was initialized using service data **#8 CLEAR, ALL**
 RX/TX : Total number of pages received/transmitted
 A4/B4/A3/LTR/LGL : Total number of pages transmitted and received for each document size
 33600 bps~2400 bps : Total number of pages transmitted and received for each modem speed
 STD/FINE/SUPER/ULTRA : Total number of pages transmitted and received for each mode
 MH/MR/MMR/JBIG : Total number of pages transmitted and received for each coding method
 G3/ECM : Total number of pages transmitted and received in each mode
 PRINT/READ : Total number of pages printed/scanned

[Display example]

PRINT = 30*/100** READ = 30*/100**

* Indicates the value input with Service Data **#8 CLEAR, COUNTER.**

** Indicates the value counted since shipment from the factory.

#000~##750

[Display example] : Total number of occurrences for each error code

##280	1	7	3	0	0
	##280	##281	##282		
	errors	errors	errors		

```

25/09/1999 13:15 FAX 0123456789          Canon Inc.          002
##750      0      0      0      0      0      0      0      0
           0      0      0      0      0      0      0      0
           0      0      0      0      0      0      0      0
           0      0      0      0      0      0      0      0
           0      0      0      0      0      0      0      0
           0      0      0      0      0      0      0      0
           0      0      0      0      0      0      0      0
           0      0      0      0      0      0      0      0

#1 LATEST          ##106

START TIME          25/09 11:37
OTHER PARTY          3362+3362
MAKER CODE           10001000
MACHINE CODE         01011101 00000000
RCV V.8 FRAME        E0 81 85 D4 90 7E 00 00
SYMBOL RATE          3429
DATA RATE             31.2
TX LVL REDUCTION     0
ERR ABCODE            00
ERR SECTXB            80
ERR SECRXB            80

Rx : (bit 1) 00000000 01000010 00011111 00100010 00000000 00000000 00000000 (bit56)
Tx : (bit 1) 00000100 01110111 00010101 00100011 00000001 00000001 00000001 (bit56)
      (bit57) 00000001 00011001 00000100 00000000 00000000 (bit96)

Rx :          NSS TSI DCS      PIX-312
Tx : NSF CSI DIS          CFR      DCN

##102
    
```

Figure 3-28 System Dump List (2/2)

- ##nnn : Service error code
- START TIME : Communication start date and time (on 24 hour clock)
- OTHER PARTY : Telephone number sent from other party
- MAKER CODE : Maker code
(For details, see Chapter 4: 3. MAKER-CODE on page 4-5)
- [1000 1000] Indicates a Canon fax
 - └─ lower nibble
 - └─ upper nibble
- RCV V.8 FRAME : Received V.8 protocol signal
- SYMBOL RATE : Symbol rate used for the primary channel
- TX LVL REDUCTION : 0 (Fixed)
- ERR ABCODE : Code output by the modem when an error occurred (Not used in the field)
- ERR SECTXB : Transmit status of the modem when an error occurred (Not used in the field)
- ERR SECRXB : Received status of the modem when an error occurred (Not used in the field)
- RX/TX : Received/transmitted protocol signal
bit 1 to bit 96 of received/transmitted DIS, DCS, or DTS



NOTE

If no service errors have occurred in the past, the above report will not be output.

a-3) Service activity report (sending/receiving)

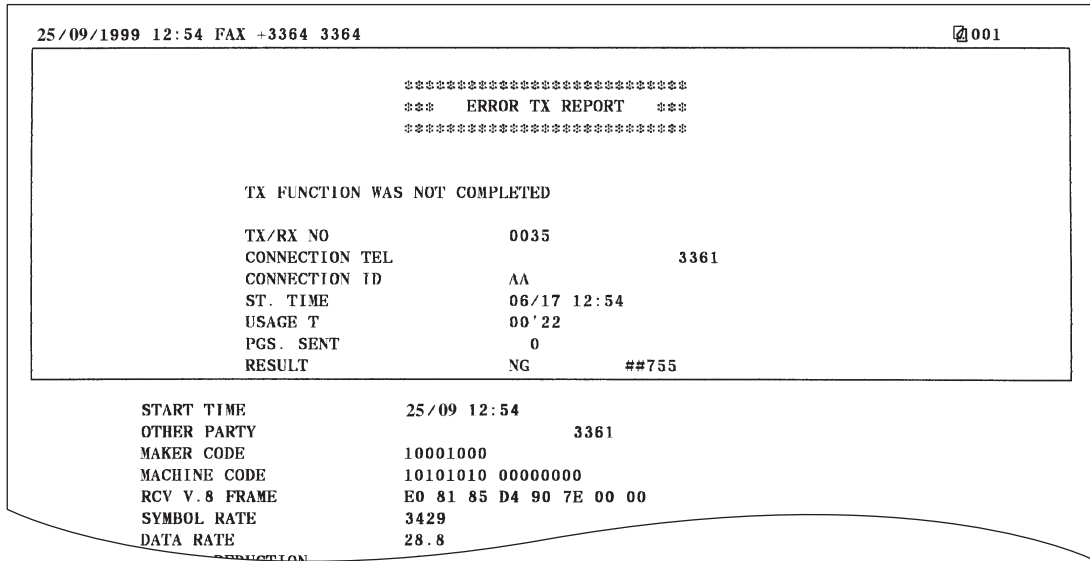

Figure 3-29 Service Error Tx Report

- Header : OK, NG messages
- TX/RX NO : Indicates four digits of the transaction number
- CONNECTION TEL (OTHER PARTY) : Number sent from the other party or number dialed (lower 20 digits)
- SUBADDRESS : Subaddress number sent from the other party
- CONNECTION ID : ID sent from the other party, if the other party is a Canon fax
- START TIME : Communication start date and time (on 24-hour display)
- USAGE TIME : Communication time (in minutes and seconds)
- PAGES : Number of pages for which transmission was complete (For details, see *User's manual*)
- RESULT : "NG" display with number of pages for which transmission was fault, and service error code
- MAKER CODE : Maker code (For details, see *Chapter 4: 3. MAKER-CODE on page 4-5*)
 - [1000 1000] Indicates a Canon fax
 - └─ lower nibble
 - └─ upper nibble
- RCV V.8 FRAME : Received V.8 protocol signal
- SYMBOL RATE : Symbol rate used for the primary channel
- TX LVL REDUCTION : 0 (Fixed)
- ERR ABCODE : Code output by the modem when an error occurred (Not used in the field)
- ERR SECTXB : Transmit status of the modem when an error occurred (Not used in the field)
- ERR SECRXB : Received status of the modem when an error occurred (Not used in the field)
- RX/TX : Received/transmitted protocol signal
bit 1 to bit 96 of received/transmitted DIS, DCS, or DTS



NOTE

The V.8/V.34-related items (RCV V.8 FRAME to ERR SECRXB) are not printed on the Normal G3 Service Activity Report.

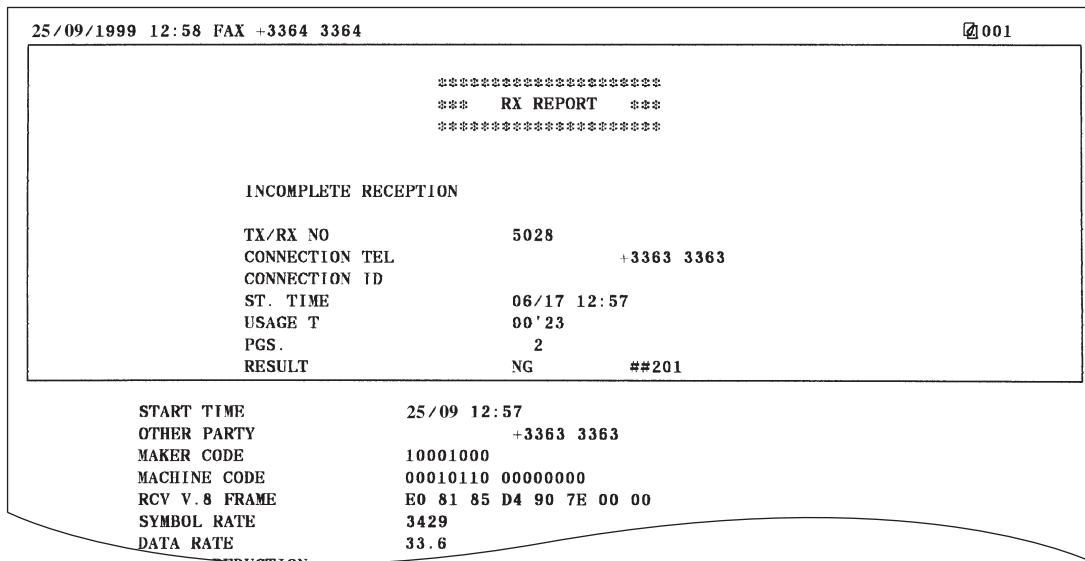

Figure 3-30 Service Error Activity Report (receiving)

- Header : OK, NG messages
- TX/RX NO : Indicates four digits of the transaction number
- CONNECTION TEL : Number sent from the other party or number dialed
- (OTHER PARTY) (lower 20 digits)
- SUBADDRESS : Subaddress number sent from the other party
- CONNECTION ID : ID sent from the other party, if the other party is a Canon fax
- START TIME : Communication start date time (on 24-hour display)
- USAGE TIME : Communication time (in minutes and seconds)
- PAGES : Number of pages for which transmission was complete
(For details, see *User's manual*)
- RESULT : "NG" display with number of pages for which
transmission was fault, and service error code
- MAKER CODE : Maker code (For details, see *Chapter 4: 3. MAKER-CODE on
page 4-5*)
[1000 1000] Indicates a Canon fax
└───┬───┘ lower nibble
└───┬───┘ upper nibble
- RCV V.8 FRAME : Received V.8 protocol signal
- SYMBOL RATE : Symbol rate used for the primary channel
- DATA RATE : Transmission speed used for the primary channel
- TX LVL REDUCTION : 0 (Fixed)
- ERR ABCODE : Code output by the modem when an error occurred (Not used in the field)
- ERR SECTXB : Transmit status of the modem when an error occurred
(Not used in the field)
- ERR SECRXB : Receive status of the modem when an error occurred
(Not used in the field)
- RX/TX : Received/transmitted protocol signal
bit 1 to bit 96 of received/transmitted DIS, DCS, or DTS



The V.8/V.34-related items (RCV V.8 FRAME to ERR SECRXB) are not printed on the Normal G3 Service Activity Report.

NOTE

8. WIRING DIAGRAM

8.1 Wiring Diagram

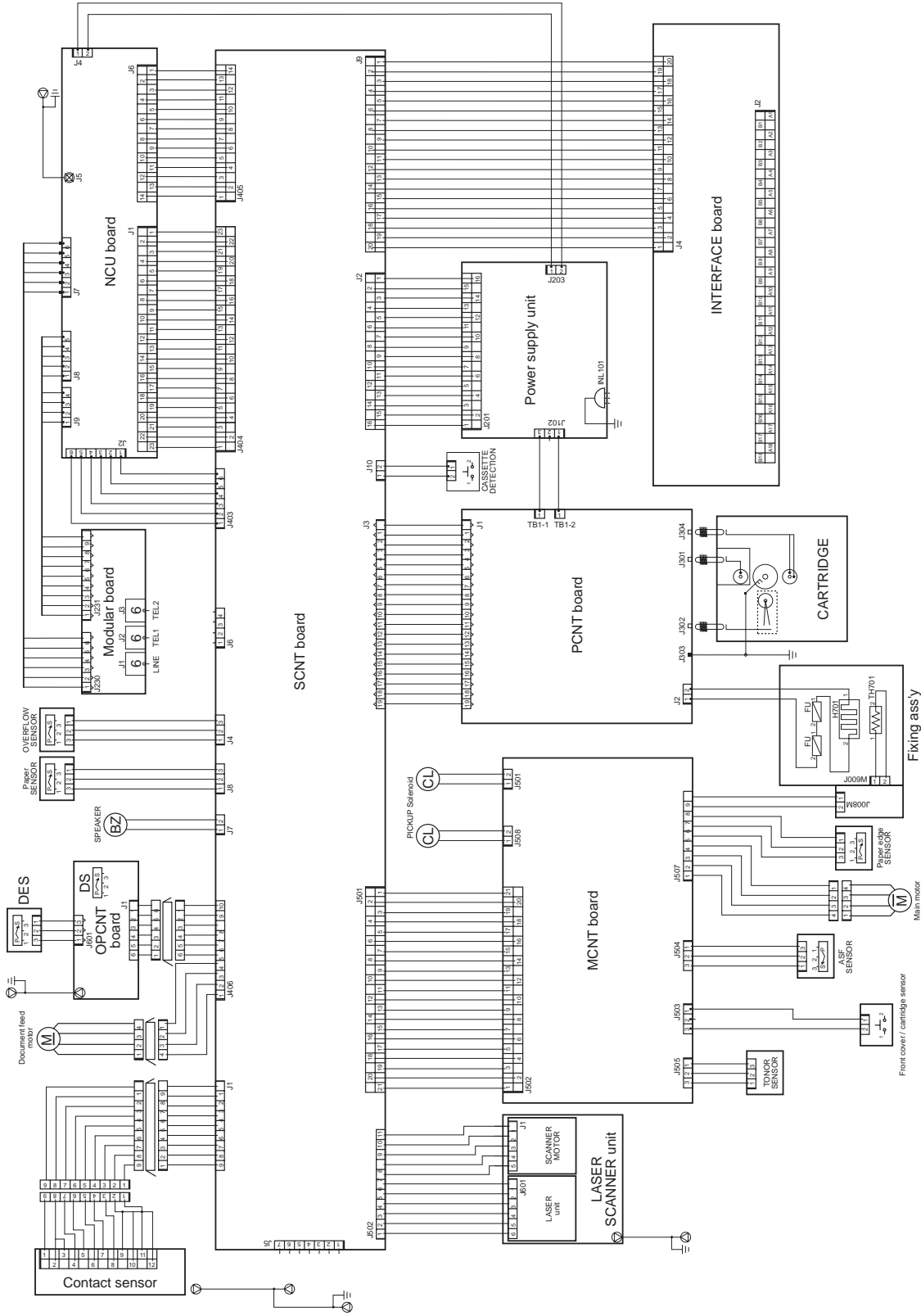

Figure 3-31 Wiring Diagram

8.2 Connector Locations and Signal Descriptions

SCNT board (J1) ← → Contact sensor

J1		sensor	Signal name	Description
1	←	1	VOUT	Analog image data
2	—	2	AGND	Analog ground
2	—	3	AGND	Analog ground
3	→	4	+5VA	Logic drive voltage
4	→	5	VREF	Image signal reference voltage
5	→	6	SH	Image scan start signal
6	→	7	CLK	Contact sensor drive clock
7	→	8	VLED	LED drive voltage
8	—	9	GND	Frame ground
8	—	10	GND	LED ground
9	—	11	LGND	Frame ground
9	—	12	LGND	Frame ground

SCNT board (J2) ← → Power supply unit (J201)

J2		J201	Signal name	Description
1	—	16	GND	Ground
2	—	15	GND	Ground
3	←	14	+3.3V	Logic drive voltage
4	—	13	GND	Ground
5	←	12	+5V	Logic drive voltage
6	←	11	+5V	Logic drive voltage
7	—	10	GND	Ground
8	←	9	+12V	Logic drive voltage
9	—	8	GND	Ground
10	—	7	GND	Ground
11	—	6	GND	Ground
12	—	5	GND	Ground
13	←	4	+12V	Motor drive voltage
14	←	3	+12V	Motor drive voltage
15	←	2	+12V	Motor drive voltage
16	←	1	+12V	Motor drive voltage

SCNT board (J3) ← → PCNT board (J1)

J3		J1	Signal name	Description
1	—	1	GND	Ground
2	→	2	RLYD	Relay control signal
3	→	3	FSRD	Fixing heater control signal
4	→	4	DVFOT	Developing AC bias drive signal
5	→	5	TRCRNT	Transfer voltage feedback signal
6	→	6	TRPWM	Transfer positive voltage drive signal
7	→	7	TRNFOT	Transfer negative voltage drive signal
8	→	8	PRACC	Primary high-voltage (AC) drive signal
9	→	9	PRDCC	Primary high-voltage (DC) drive signal
10	→	10	DVDCC	Developing DC bias drive signal
11	←	11	POSNS	Paper detection signal
12	←	12	FSRTH	Fixing heater temperature detect signal
13	→	13	+5V	Logic drive voltage
14	→	14	+5V	Logic drive voltage
15	—	15	GND5	Ground
16	→	16	+12R	Relay drive voltage
17	—	17	GND12	Ground
18	—	18	GND12	Ground
19	→	19	+12HB	High voltage circuit drive voltage

SCNT board (J4) ← → Overflow sensor

J4		overflow	Signal name	Description
1	→	—	+5V	Overflow sensor drive voltage
2	—	—	GND	Ground
3	←	—	OVERFLOW	Overflow sensor detection signal

SCNT board (J7) ← → Speaker

J7		speaker	Signal name	Description
1	→	—	VO2	Speaker drive
2	→	—	VO1	Speaker drive

SCNT board (J8) ← → Paper sensor

J8		PS	Signal name	Description
1	→	—	+5V	Paper sensor drive voltage
2	—	—	GND	Ground
3	←	—	CPAPER	Cassette Paper detection signal

SCNT board (J10) ← → Cassette detection sensor

J10		Cassette	Signal name	Description
1	←	—	CAS	Cassette detection signal
2	—	—	GND	Ground

SCNT board (J403) ← → NCU board (J2)

J403		J2	Signal name	Description
1	—	6	AGND	Ground
2	→	5	+5V	Not used
3	→	4	+12V	Analog device, Relay drive voltage
4	—	3	AIN	Line monitor signal
5	→	2	TX	Telephone line transmission signal
6	←	1	RX	Telephone line reception signal

SCNT board (J404) ← → NCU board (J1)

J404		J1	Signal name	Description
1	—	23	DGND	Ground
2	←	22	BIT3	for future use
3	←	21	BIT2	for future use
4	←	20	BIT1	for future use
5	—	19	LPL2	Not used
6	—	18	LPL1	Not used
7	—	17	HOOK2	Not used
8	←	16	HOOK1	Telephone off hook detection signal
9	←	15	CIOR	CI signal 1 (CI1 or CI2)
10	←	14	CI2	CI detection signal 2
11	←	13	CI1	CI detection signal 1
12	—	12	LPRD	Not used
13	→	11	DCRD	DC relay control signal
14	→	10	CMLD	CML relay control signal
15	→	9	HRD	H relay control signal
16	→	8	PRD	P relay control signal
17	→	7	SRD	S relay control signal
18	—	6	AGND	Ground
19	—	5	N.C.	Not used
20	→	4	+12V	+12V
21	→	3	+3.3V	Logic drive signal (for ESS)
22	→	2	+3.3V	Logic drive signal
23	—	1	DGND	Ground

SCNT board (J405) ← → NCU board (J6)

J405		J6	Signal name	Description
1	—	14	OUT	Direct current of line detection signal
2	→	13	IPSEL1	HIC terminal impedance setting
3	→	12	IPSEL2	HIC terminal impedance setting
4	—	11	IPSEL3	HIC terminal impedance setting
5	→	10	DCSEL	DC registance switching when line is connected
6	←	9	DCLIM	DC current limitation control signal
7	←	8	RRD	R relay control signal
8	←	7	NOR	CI reception sensitivity setting signal when no ringing reception
9	←	6	C1	DC cut capacitor selection signal
10	←	5	C2	DC cut capacitor selection signal
11	←	4	CIST1	CI reception sensitivity setting signal
12	←	3	CIST2	CI reception sensitivity setting signal
13	←	2	AST	For Australian regulations signal
14	←	1	NZ	For N.Z. regulations signal

SCNT board (J406) ← → Document feed motor / OPCNT board (J1)

J406		motor/J1	Signal name	Description
1	→	—	RA	Phase A
2	→	—	RA*	Phase -A
3	→	—	RB	Phase B
4	→	—	RB*	Phase -B
5	→	6	+5V	Logic drive voltage
6	→	5	KIN	Status signal for keys, and sensors
7	→	4	XRST	Reset signal
8	←	3	KOUT	Control signal for LEDs, display
9	—	2	GND	Ground
10	→	1	KCLK	Clock signal

SCNT board (J501) ← → MCNT board (J502)

J501		J502	Signal name	Description
1	→	21	A*	Phase -A
2	→	20	A	Phase A
3	←	19	FSRTH	Fixing heater temperature detection signal
4	→	18	APUD	ASF Pickup solenoid drive signal
5	←	17	PISNS	Paper edge sensor detection signal
6	→	16	CPUD	Cassette pickup solenoid control signal
7	→	15	+5VA	Logic drive voltage
8	→	14	+5VA	Logic drive voltage
9	→	13	B	Phase B
10	←	12	APAPER	ASF paper detection signal
11	→	11	B*	Phase -B
12	—	10	GND5	Ground
13	—	9	GND5	Ground
14	←	8	TONOR	Toner detection signal
15	→	7	+12M	Main motor drive voltage
16	→	6	+5VB	Logic drive voltage
17	→	5	+12M	Main motor drive voltage
18	→	4	+12R	Front cover/cartridge sensor and solenoid drive voltage
19	—	3	GND12A	Ground
20	—	2	GND12A	Ground
21	←	1	+12HA	+12V after front cover/cartridge sensor

SCNT board (J502) ← → Laser scanner

J502		scanner	Signal name	Description
1	→	6	+5V	Logic drive voltage
2	→	5	APCSH	APC sample hold signal
3	→	4	LON*	Laser on signal
4	—	3	GND	Ground
5	→	2	VDOUT*	Laser drive signal
6	←	1	BDI*	Horizontal sync signal
7	→	5	+12V	Scanner motor drive voltage
8	←	4	SCNTAC	Scanner rotation rate monitor signal
9	—	3	GND12	Ground
10	→	2	SCNON*	Scanner motor drive signal
11	→	1	SCNCLK	Scanner reference clock signal

PCNT board (J2) ← → Fixing ass'y

J2		fixing	Signal name	Description
1	→	1	AC-H	AC 120V household current
2	→	2	AC-N	AC 120V household current

MCNT board (J501) ← → pickup solenoid

J501		solenoid	Signal name	Description
1	←	—	CPUD	Pickup solenoid drive signal
2	→	—	+12V	Pickup solenoid drive voltage

MCNT board (J503) ← → Front cover/cartridge sensor

J503		FS/CS	Signal name	Description
1	→	—	+12VHA	After front cover/cartridge sensor
2	—	—	GND	Ground
3	→	—	+12R	Before front cover/cartridge sensor

MCNT board (J504) ← → ASF sensor

J504		ASF	Signal name	Description
1	→	—	APAPER	ASF paper detection sensor drive voltage
2	—	—	GND	Ground
3	←	—	POW1	ASF paper detection signal

MCNT board (J505) ← → Tonor sensor

J505		Tonor	Signal name	Description
1	—	—	GND	Ground
2	←	—	TONOR	Remaining tonor detection signal
3	→	—	+5V	Tonor sensor drive voltage

MCNT board (J507) ← → Main motor/Paper edge sensor/Fixing ass'y

J507		motor	Signal name	Description
1	→	—	WA	Phase A
2	→	—	WA*	Phase -A
3	→	—	WB	Phase B
4	→	—	WB*	Phase -B
5	→	—	POW2	Paper pickup detection sensor drive voltage
6	—	—	GND	Ground
7	←	—	PISNS	Paper pickup detection signal
8	←	—	FSRTH	Fixing heater temperature detection signal
9	—	—	GND	Ground

MCNT board (J508) ← → Pickup solenoid

J508		solenoid	Signal name	Description
1	←	—	APUD	ASF Pickup solenoid drive signal
2	→	—	+12V	Pickup solenoid drive voltage

NCU board (J4) ← → Power Supply unit (J203)

J4		J203	Signal name	Description
1	←	2	VH	For telephone offhook detection during communication
2	—	1	VH-GND	Ground

NCU board (J5) ← → to Grounding wire

J5		G.wire	Signal name	Description
1	—	—	ARG	Ground (arrester)

NCU board (J7) ← → Modular board (J230)

J7		J230	Signal name	Description
1	—	1	T2	Line from L1, L2 to wall socket via the fax
2	—	2	W	Line from handset terminal T11 in priority mode (handset/extension telephone). Goes into T21 of the extension telephone.
3	—	3	L2	Telephone line
4	—	4	L1	Telephone line
5	—	5	R	Earth signal for PBX
6	—	6	T1	Line from L1, L2 to wall socket via the fax

NCU board (J8) ← → Modular board (J231)

J8		J231	Signal name	Description
1	—	9	A	Line from handset terminal T12 in priority mode (handset/extension telephone). Goes into T22 of the extension telephone.
2	—	8	W	Line from handset terminal T11 in priority mode (handset/extension telephone). Goes into T21 of the extension telephone.
3	—	7	T12	Handset terminal telephone line via the fax
4	—	6	T11	Handset terminal telephone line via the fax
5	—	5	R	Earth signal for PBX

NCU board (J9) ← → Modular board (J231)

J9		J231	Signal name	Description
1	—	4	W	Line from handset terminal T11 in priority mode (handset/extension telephone). Goes into T21 of the extension telephone.
2	—	3	T22	Extension telephone terminal telephone line via the fax.
3	—	2	T21	Extension telephone terminal telephone line via the fax.
4	—	1	R	Earth signal for PBX

Power supply unit (J102) ← → PCNT board (TB1)

J102		TB1	Signal name	Description
1	→	2	AC-N	230V household current
2	→	1	AC-H	230V household current

Modular board (J1) ← → Line

J1		Line	Signal name	Description
1	—	—	T2	Not used
2	—	—	W	Not used
3	—	—	L2	Telephone line
4	—	—	L1	Telephone line
5	—	—	R	Not used
6	—	—	T1	Not used

Modular board (J2) ← → extension telephone

J2		EXT.Tel	Signal name	Description
1	—	—	—	Not used
2	—	—	W	Not used
3	—	—	T2	Extension telephone terminal telephone line via the fax
4	—	—	T1	Extension telephone terminal telephone line via the fax
5	—	—	R	Not used
6	—	—	—	Not used

Modular board (J3) ← → handset

J3		handset	Signal name	Description
1	—	—	A	Not used
2	—	—	W	Not used
3	—	—	T2	Handset terminal telephone line via the fax
4	—	—	T1	Handset terminal telephone line via the fax
5	—	—	R	Not used
6	—	—	—	Not used

SCNT board (J9) ← → INTERFACE board (J4)

J9		J4	Signal name	Description
1	—	20	GND	Ground
2	—	19	GND	Ground
3	←	18	HSELIN	Host drive signal
4	←	17	HSTB	Host drive signal
5	→	16	+5V	Peripheral power
6	—	15	HPD0	Data bus
7	→	14	HXFALT	Peripheral drive signal
8	—	13	HPD1	Data bus
9	←	12	HAUTOFD	Host drive signal
10	—	11	HPD2	Data bus
11	←	10	HINIT	Host drive signal
12	—	9	HPD3	Data bus
13	→	8	HSELECT	Peripheral drive signal
14	—	7	HPD4	Data bus
15	→	6	HERROR	Peripheral drive signal
16	—	5	HPD5	Data bus
17	→	4	HBUSY	Peripheral drive signal
18	—	3	HPD6	Data bus
19	→	2	HXACK	Peripheral drive signal
20	—	1	HPD7	Data bus

INTERFACE board (J2) ← → to Host parallel interface

J2		Host	Signal name	Description
1	—	—	HSTB	STROBE*1
2	—	—	GND	Ground
3	—	—	CD0	Data bus
4	—	—	GND	Ground
5	—	—	CD1	Data bus
6	—	—	GND	Ground
7	—	—	CD2	Data bus
8	—	—	GND	Ground
9	—	—	CD3	Data bus
10	—	—	GND	Ground
11	—	—	CD4	Data bus
12	—	—	GND	Ground
13	—	—	CD5	Data bus
14	—	—	GND	Ground
15	—	—	CD6	Data bus
16	—	—	GND	Ground
17	—	—	CD7	Data bus
18	—	—	GND	Ground
19	—	—	nACK	*2
20	—	—	GND	Ground
21	—	—	BUSY	*3
22	—	—	GND	Ground
23	—	—	PERROR	P.E.*4
24	—	—	GND	Ground
25	—	—	SELECT	SELECT*5
26	—	—	INIT	*7
27	—	—	nAUTOFD	AUTO FEED XT*6
28	—	—	nFAULT	Printer interrupt signal
29	—	—	N.C.	Not used
30	—	—	GND	Ground
31	—	—	GND	Ground
32	—	—	N.C.	Not used
33	—	—	GND	Ground
34	—	—	+5V*2	Peripheral power
35	—	—	+5V*2	Peripheral power
36	—	—	nSELCTIN	SLCT IN

*1 Data transmission synchronizing signal (Forward direction)

*2 Data transmission synchronizing signal (Reverse direction)

*3 Data reception completion signal (Forward direction)

*4 Data transmission direction change response signal

*5 Extension request response signal

*6 Data reception completion signal (Reverse direction)

*7 Data transmission direction change request signal

This page intentionally left blank

Chapter 4

Appendix

1. INSTALLING THE FAX-L350



REFERENCE

This machine has been designed for user installation. Therefore, this manual contains only an outline description of the procedures. For details of the installation, see the *USER'S GUIDE*.

1.1 Setting Up

- Choosing a Location for Your FAX-L350
Before you set up Your FAX-L350, make sure you have read cautions of setting up FAX-L350.
- Unpacking Your FAX-L350
Check that nothing is missing when the unit is unpacked.
- Assembling the FAX-L350
- Making Connections
Connect the telephone line, a telephone, an answering machine or the power cord.
- **Service Data Setting (#5 TYPE)**
Set the country type to suit the communication standard used in your country.
- The Toner Cartridge
- Loading Recording Paper
Set paper in the auto sheet feeder and cassette, set the size of paper that is to be used.
- Setting the telephone line type
Select the correct telephone line type in **TEL LINE TYPE**.
- Entering user information
Enter user information, such as **DATE & TIME, UNIT TELEPHONE #, UNIT NAME**.

1.2 Checking Operations

- Copy operation
Make a copy, and check that the operation is normal.
- Communication test
Transmit to, and receive from other facsimiles, and check that images are sent normally when transmitted, and are printed normally when received.



What to do when trouble occurs

Very rarely, during use, the display may go out, all the buttons may stop working, or some other trouble may occur because of strong electrical noise or a large amount of static. If such trouble occurs, initialize the RAM. During installation, we recommend that you perform the all clear operation after the power on. Refer to *NOTE: "ALL clear" when nothing works on Page 1-40*.

2. OPTION

2.1 HANDSET KIT

The optional handset is available. Make sure you have the following items. If anything is damaged or missing, notify your Canon dealer immediately.

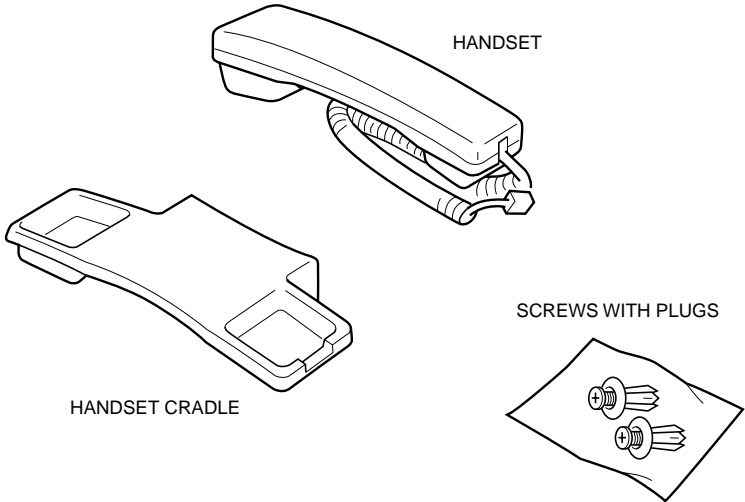

Attaching the Handset to Your Unit

To attach the handset to your unit, follow these steps:

1. Remove the screws from the plugs and insert the plugs into the holes on the handset cradle.

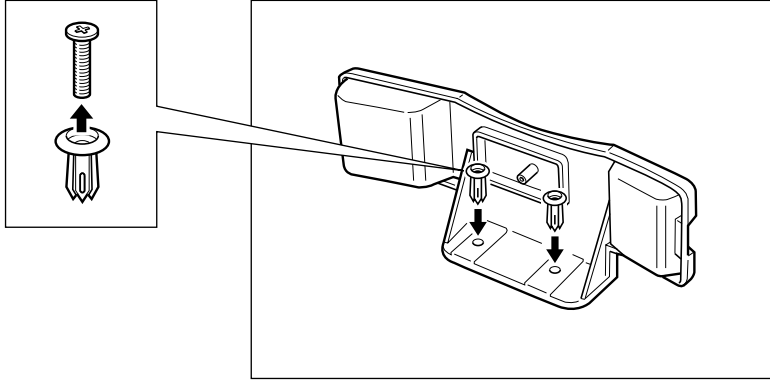

2. Insert the plugs with the handset cradle in the holes on the unit.

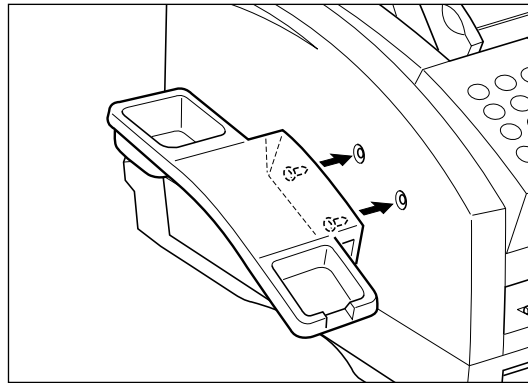

Note

If you have difficulty inserting the plugs, turn the unit so that the left side is facing you and the right side is placed against a wall. This will allow you to insert the plugs without the unit moving.

3. Insert the screws into the plugs and push them in with your finger.

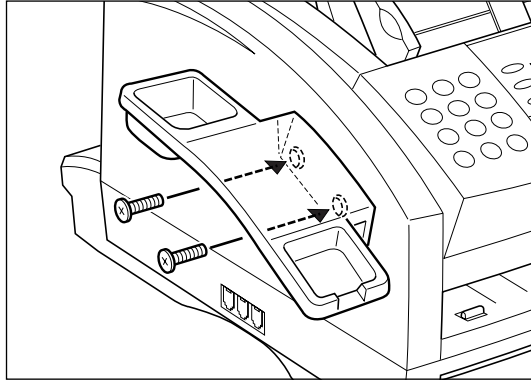

Note

- If you cannot push the screws in with your finger, use a Phillips screwdriver to push them in. (Do not screw them in as the screws may break.)
- Make sure the screws are inserted all the way into the plugs.

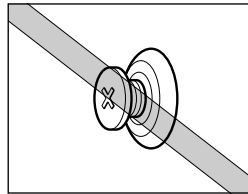
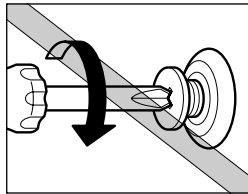

4. Connect the handset cord to the input jack marked  at the left side of the unit.

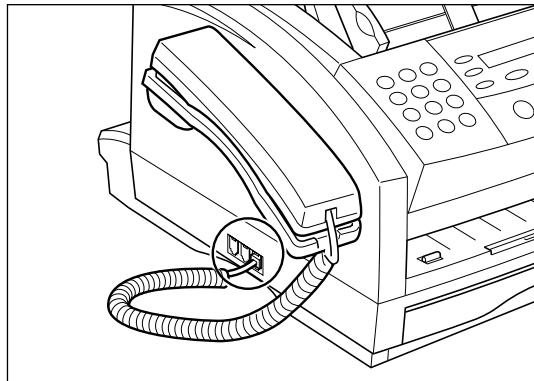
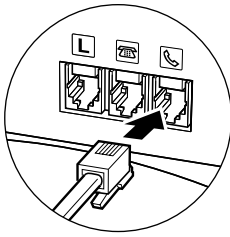

Caution

When carrying the unit, do not lift it by the handset cradle as it may break.

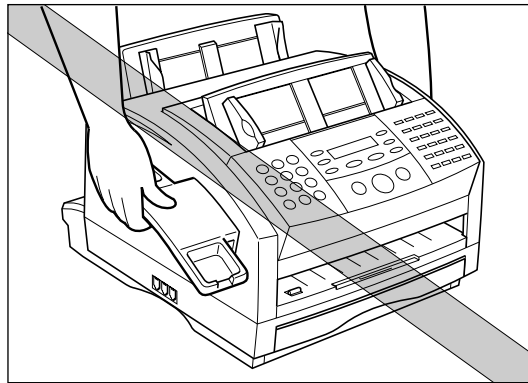

Note

If you need to remove the handset cradle after it is installed, use a small Phillips screwdriver to remove the two screws.

Adjusting the Ringer Switch

The ringer volume switch allows you to select the ring volume of the handset for incoming calls. Use a pen or other pointed object to adjust the switch to high or low.

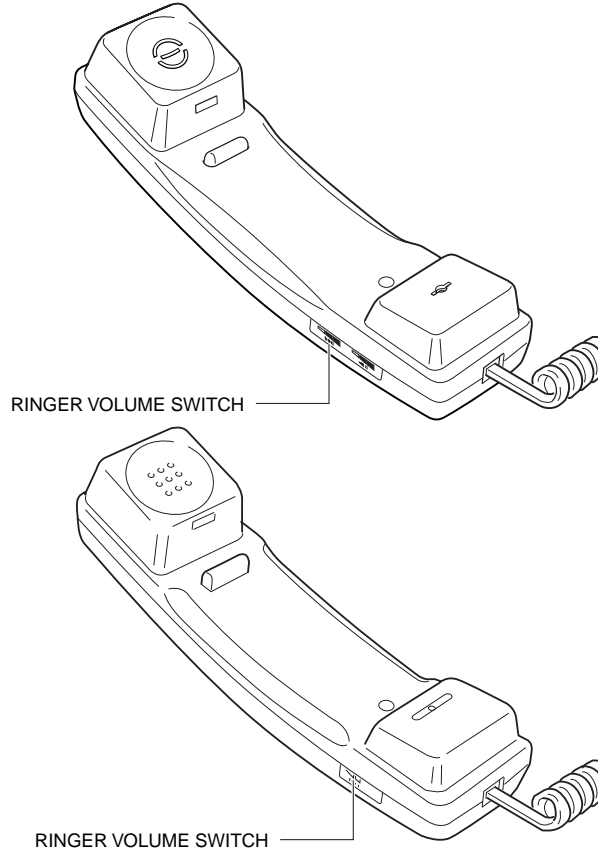

- Although there are two types of optional handsets, the functions and performance are identical. The type of handsets you can connect is different depending on the area you use your FAX-L350.



Ringer Equivalence Number (R.E.N.) (UK only)

Your British Telecom line has a maximum R.E.N. capacity of 4. Your Canon unit has a R.E.N. value of 1 (unless otherwise stated), and this handset also has a R.E.N. value of 1. You can therefore use additional equipment with a total R.E.N. value of up to 2.

If the R.E.N. value exceeds 4, the ringer volume will be reduced and one or more of the connected equipment may not function.

Maintaining Your Handset

Follow these guidelines to maintain your handset in top working condition.

- Do not leave your handset exposed to direct sunlight.
- Do not install your handset in hot or humid conditions.
- Do not spray aerosol polishes on your handset as they may enter the holes on your handset and cause damage.
- Use a damp cloth to clean your handset.

3. USER DATA FLOW

3.1 User Data Flow (by Operation Panel)

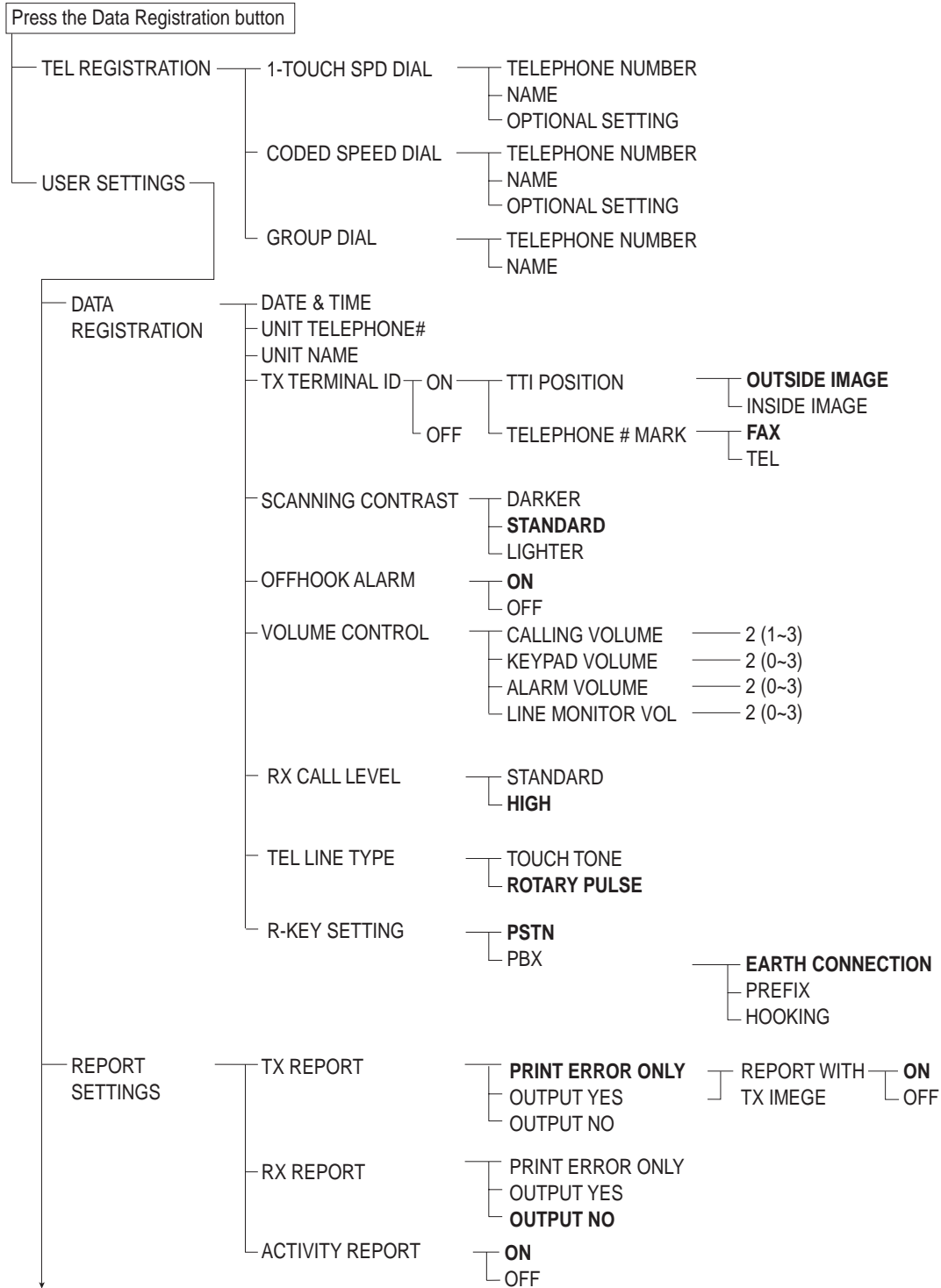

Figure 4-1 User Data Flow (1/3)

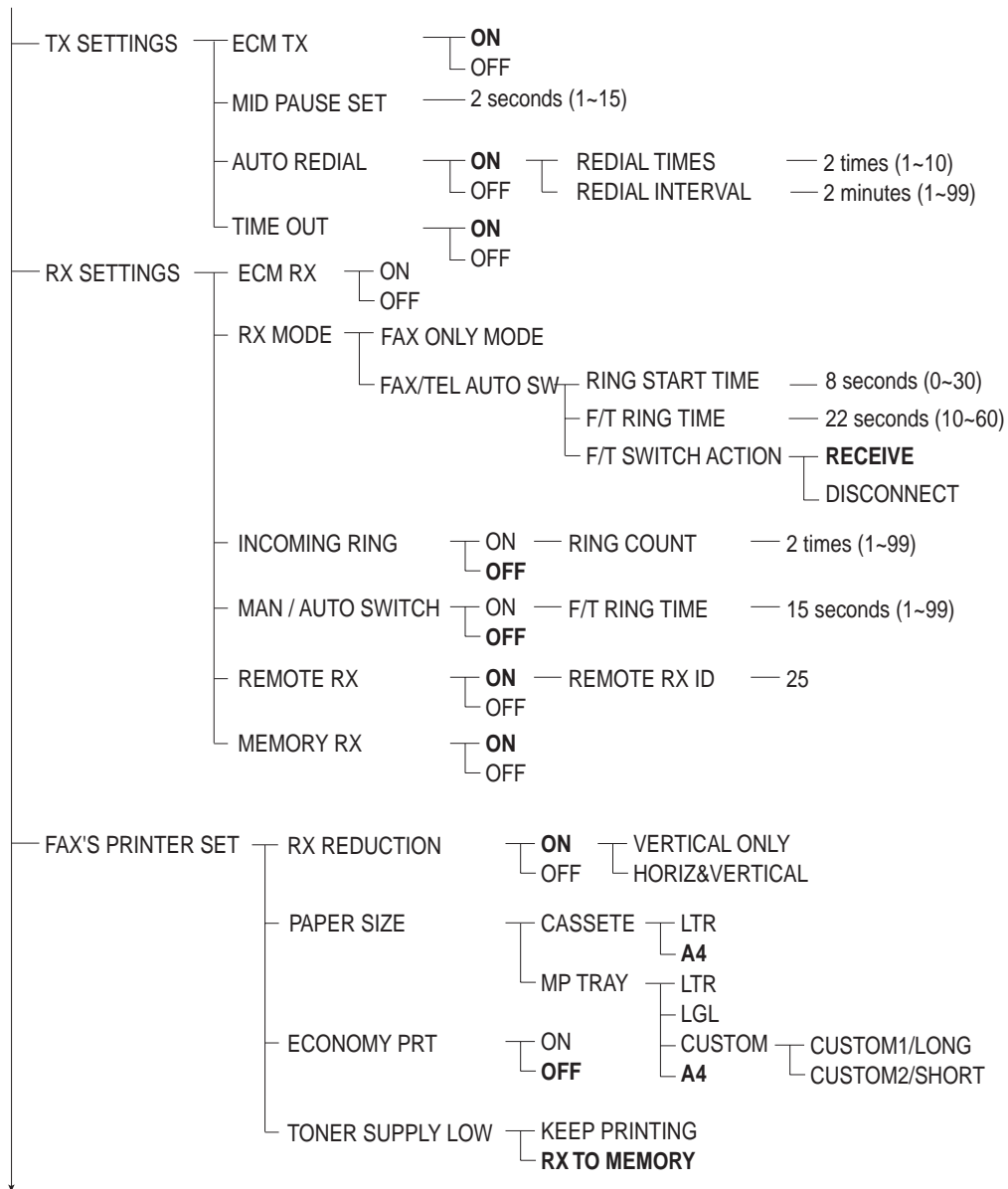

Figure 4-2 User Data Flow (2/3)

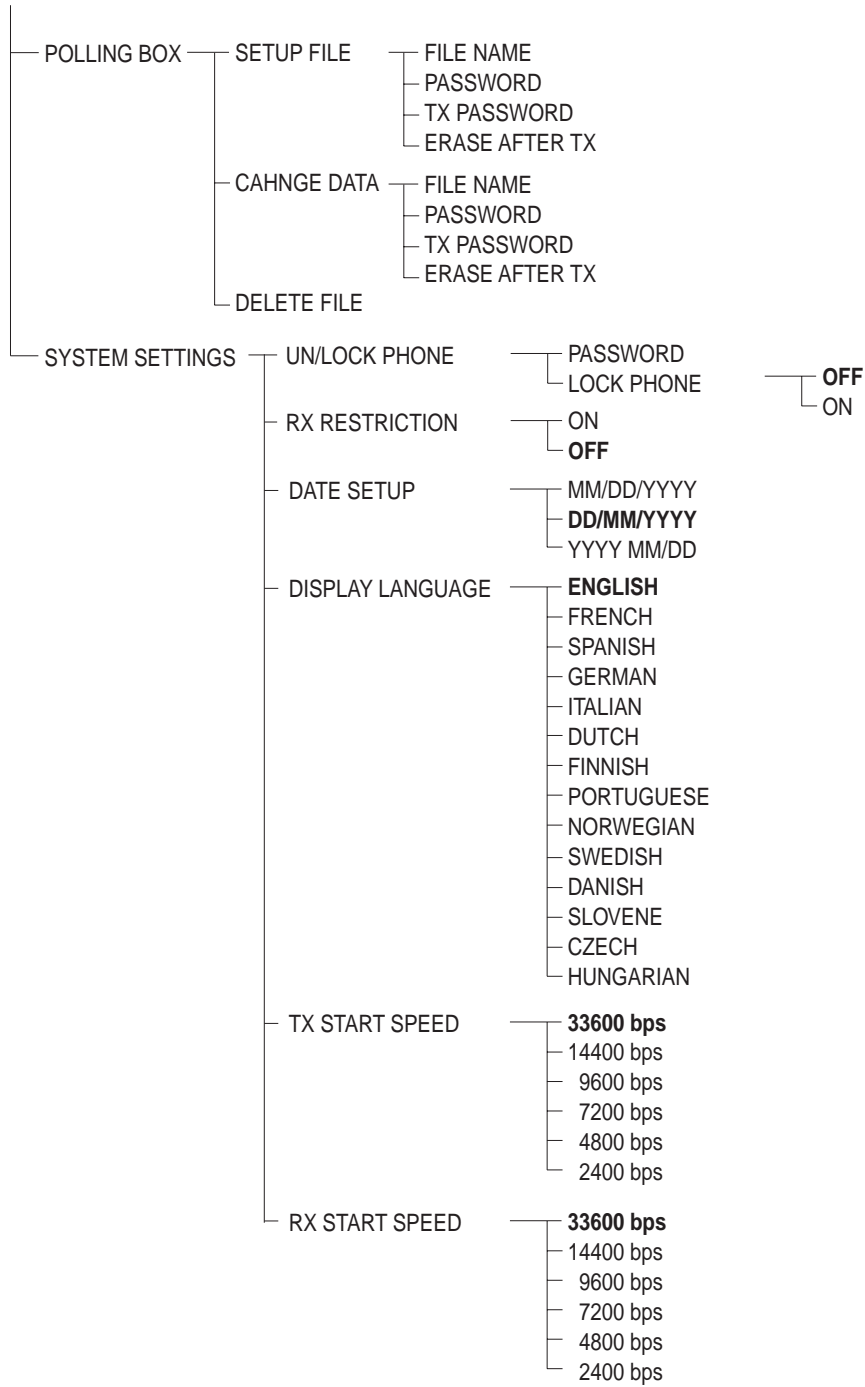
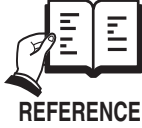

Figure 4-3 User Data Flow (3/3)

4. MAKER CODE

The 1-byte maker code displayed on the error dump list corresponds to the list of makers shown below.



For a sample of a dump list containing maker codes, see pages 3-70~3-74.

	0	1	2	3	4	5	6	7	8	9	A	B	C	D	E	F
0	0000	0001	0010	0011	0100	0101	0110	0111	1000	1001	1010	1011	1100	1101	1110	1111
1	○	○	○	○	○	○	○	○	○	○	○	○	○	○	○	○
2	○	○	○	○	○	○	○	○	○	○	○	○	○	○	○	○
3	○	○	○	○	○	○	○	○	○	○	○	○	○	○	○	○
4	△	△	△	△	△	△	△	△	△	△	△	△	△	△	△	△
5	□	□	□	□	□	□	□	□	□	□	□	□	□	□	□	□
6	MASTER NET				KONICA		MITA				BROTHER					
7																
8	ANRITSU		IWASAKI (DEX)				CASIO		Canon		SANYO		SHARP		TAMURA	
9	TOSHIBA	NEC			OKI		HITACHI		FUJIXEROX		FUJITSU		MATSUSHITA ELECTRIC		PANASONIC (MATSUSHITA)	
A	MITSUBISHI	MURATA			JRC		OMRON		TOYO		NITTSUKO		MATSUSHITA COMMUNICATION		TEC	
B	LOGIC SYSTEM INTER.	OKURA			SONY		HITACHI TELECOM TECH.		HITACHI SOFTWARE		KUONI		IBM JAPAN		SILVER	
C																
D																
E																
F																

○ : National organization △ : NTT □ : KDD

Figure 4-4 Maker Code

This page intentionally left blank



Printed on paper that
contains 60% reused paper.

Canon